

MAFAEL

Notice JUNO

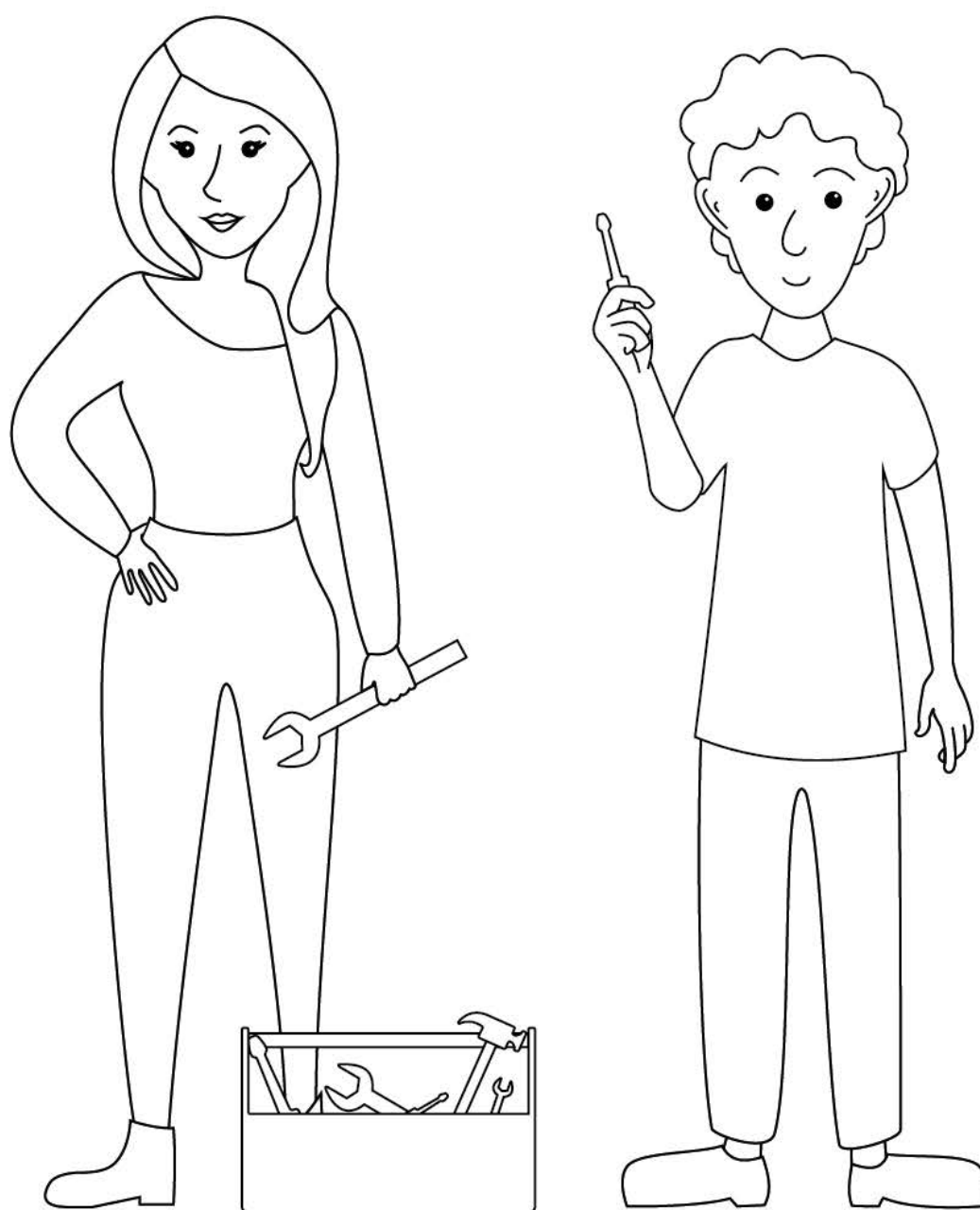

4-6h



x2

JUNO

Horizon 140

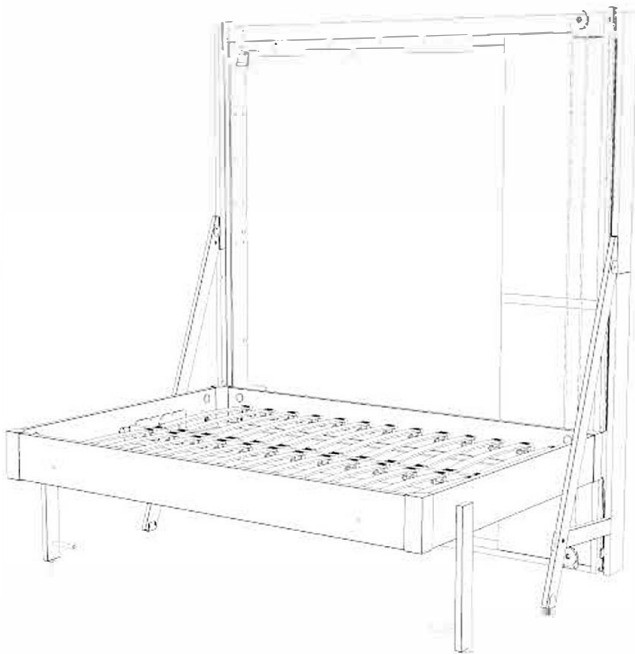

Horizon 160



Vertikal 140



Vertikal 160



CUSTOMIZE YOUR PULLEYS

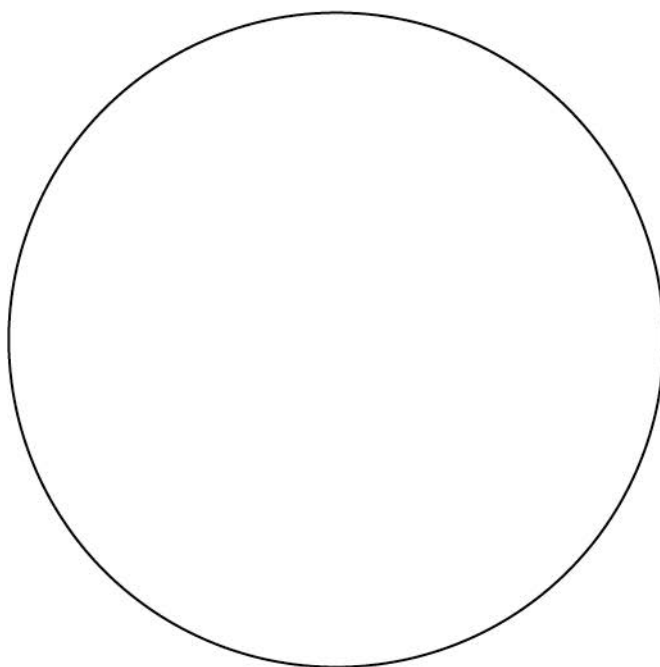
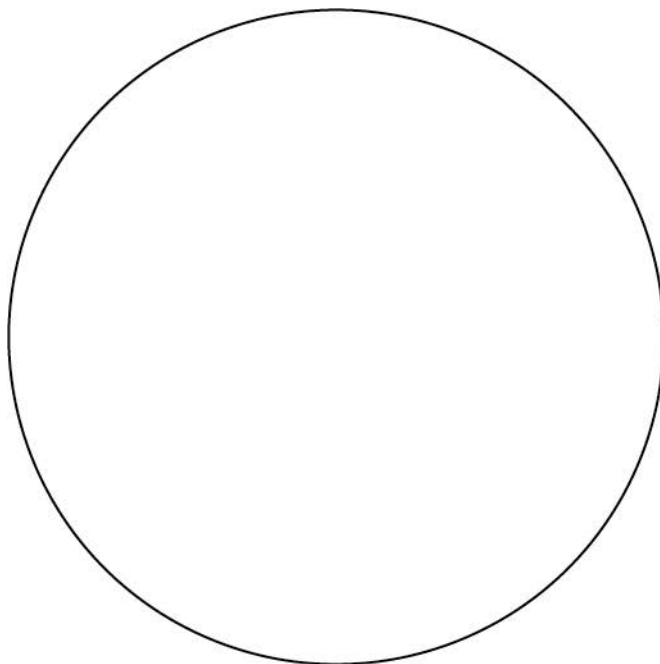

JUNO, the bold bed for small spaces



MAFAEL, a pure player in space-saving furnishings, presents JUNO, the bold 100% MADE IN FRANCE foldaway bed...

The JUNO retractable bed consists of a wall structure and a mobile bed tray. It is fitted with a fully mechanical lifting system that is both reliable and silent, making it easy to handle and suitable for everyday use.

4 models are available

- **JUNO Horizon 140**

The structure is parallel to the wall, the bed frame accommodates a 140x200 cm mattress.

- **JUNO Horizon 160**

The structure is parallel to the wall, the bed frame accommodates a 160x200 cm mattress.

- **JUNO Vertikal 140**

The structure is perpendicular to the wall, the bed frame accommodates a 140x200 cm mattress.

- **JUNO Vertikal 160**

The structure is perpendicular to the wall, the bed frame accommodates a 160x200 cm mattress.

The model is chosen by the customer at the time of ordering on mafael.com.

These instructions are common to all JUNO models. We will assist you by specifying, if necessary, the name of the model and the side of the counterweight concerned.

During assembly, you will have to choose the position of the counterweight, right or left. The main criterion is the accessibility of the rope, which will enable you to raise or lower the bed easily. Do not place the counterweight near a corner or along a wall that is difficult to access.

To help you during assembly, two icons symbolise the bed with counterweight on the right and left.

The bed with the counterweight on the right is represented by the following icon:

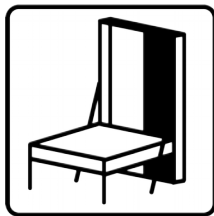

The bed with the counterweight on the left is represented by the following icon:

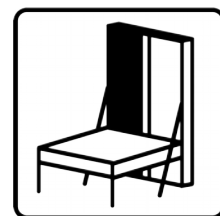

JUNO materials

- Bed frame: fnition melamine-coated chipboard in cashmere, mdf, white melamine
- Bed frame and rails : Solid Landes pine
- Bed base : beech slats
- Bed base: B1 fire-retardant technical fabric, 100% polyester. **Do not put any sharp or pointed objects under/on the fabric and wash your hands thoroughly before fitting/removing.**

OVERALL DIMENSIONS

JUNO Vertikal 140

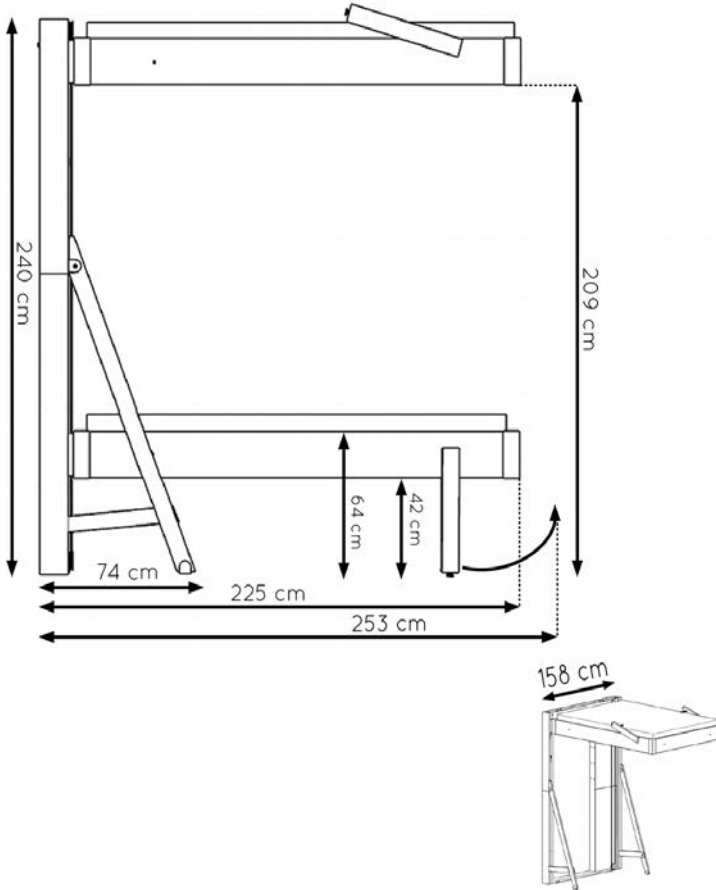

JUNO Vertikal 160

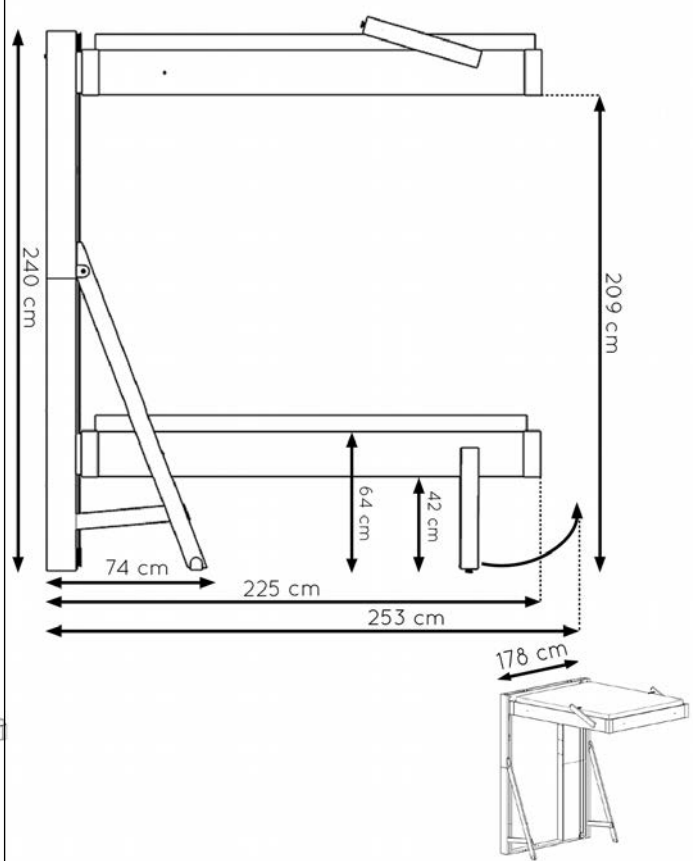

JUNO Horizon 140

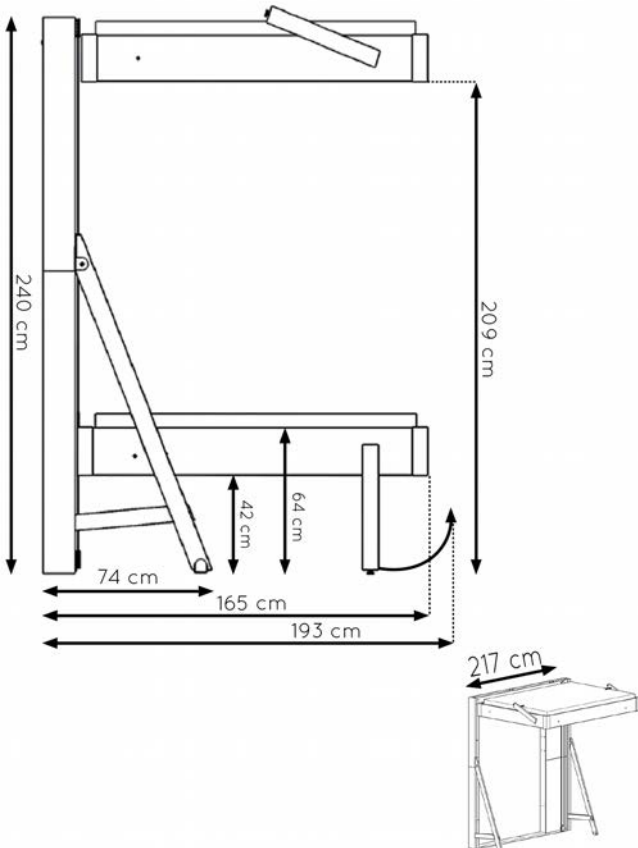

JUNO Horizon 160

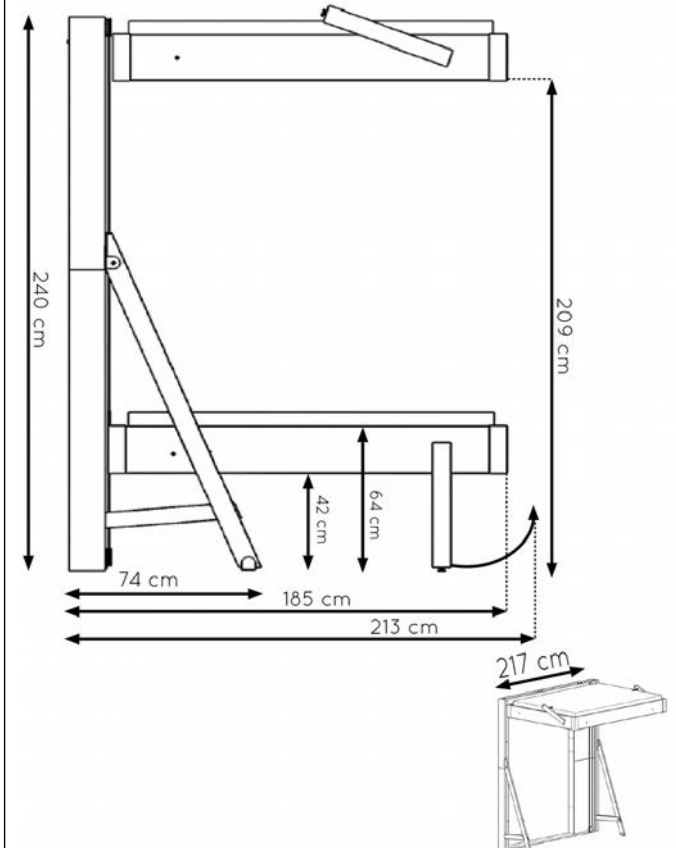

For assembly, add a further 20 cm on each side of the frame.
We recommend a 60 cm circulation space around the bed.

RECOMMENDATIONS

243 cm

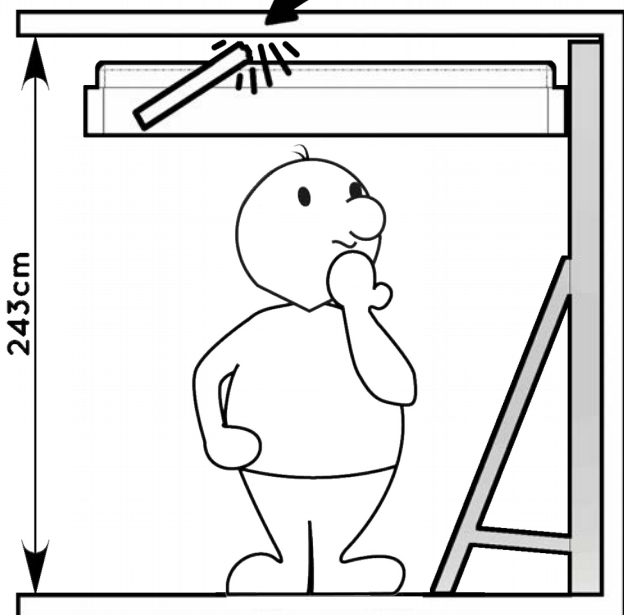

250 cm  OK

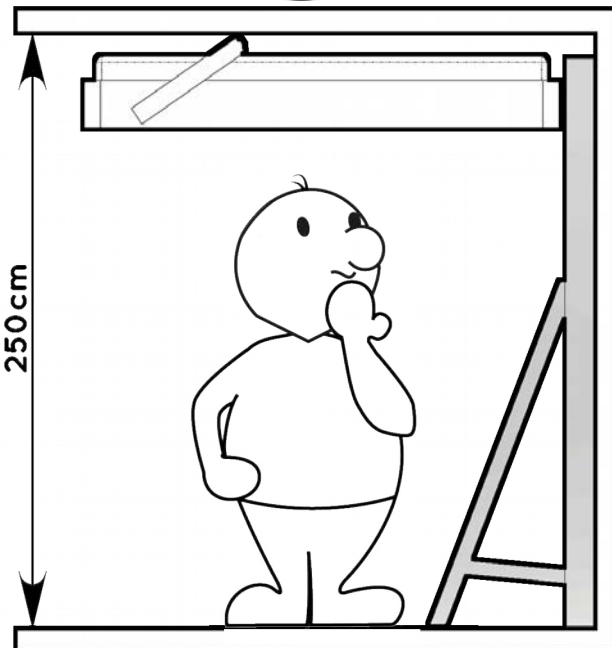

JUNO has been designed to meet the standards of rooms with a ceiling height of 250 cm.



For safety reasons, do not install any ceiling lights above the foldaway bed.

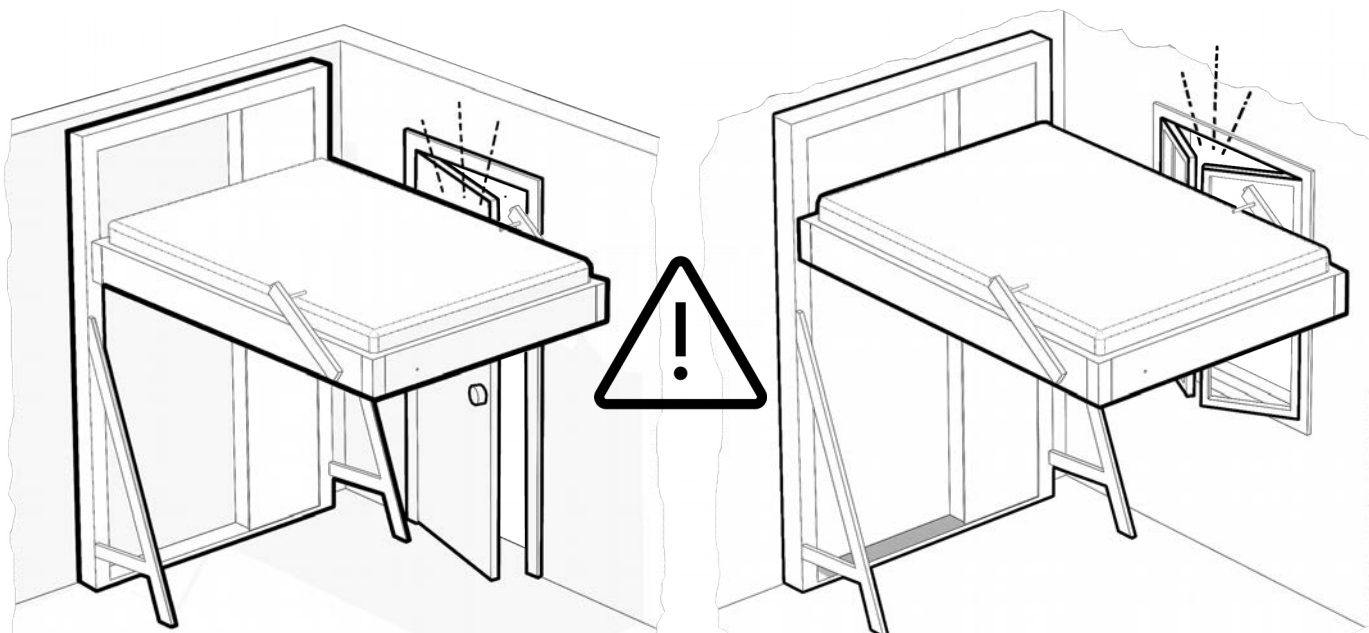

Think about your openings (doors, windows, cupboards...) so that you can operate your bed in day or night mode.

Designation	Measurements	Comments
Skirtings	up to 3 cm - recommendation : 1 cm	When there is no skirting board, a 1 cm shim should be placed behind the footboard of the bed.
Walls / Floors		Remember to measure the level and vertical of your surfaces, so that they are as plumb as possible.
Counter skirting / quarter round		Don't use.
Maximum weight on bed	250 kg	
Mattress characteristics	Must not exceed 35 kg	Do not use water mattresses or mattresses with mechanisms

FIXINGS

Thanks to its self-supporting struts, the JUNO retractable bed can be fixed to all types of wall. MAFAEL supplies two universal wall fixings that can be adapted to any wall (plasterboard, load-bearing walls, etc.).

If you have any questions about the type of screw suitable for your wall, we recommend that you consult a specialist.



Always fix your JUNO to a wall. Adapt your fixing to your wall. Never allow children to play on or hang from the retractable bed.

ADJUSTING THE JACKS

Your JUNO bed is equipped with jacks:

- 2 jacks at the ends of the bed legs
- 2 jacks at the end of the sliders
- 2 jacks at the ends of the struts

To ensure that your bed is stable, apply slight pressure with your hand to the bed frame on the wall frame side, check that your bed is stable, that all **the jacks are touching the floor, the bed legs must be placed on the floor and unfolded at right angles, lock the legs with the pins.**

Your JUNO retractable bed may change over time. Changes in temperature and humidity can alter the volume of your bed, so you may feel it floating or become unstable. In this case, check the jacks and repeat the adjustment instructions.

Detailed explanation at the end of these instructions.

BALANCING

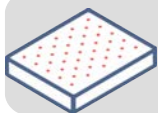

You must bring your mattress and bedding (pillows, sheets, duvet...) with you on the day of assembly to balance the bed.

If you change your bedding (mattress, duvet from winter to summer....), your JUNO may be more difficult to handle or, on the contrary, it may rise too easily, in which case you need to rebalance it.

Case 1: Change of less than 4 kg

In this case, you can balance your bed using the 2kg weights supplied with your JUNO. You can easily add or remove a weight from the bed plate: there are small metal hooks on the inside of the bed frame to hold the weights. Always remember to secure the weight with the screw provided.

- If the bed rises by itself, add 1 or 2 2 kg weights
- If the bed goes down by itself, remove 1 or 2 weights of 2 kg

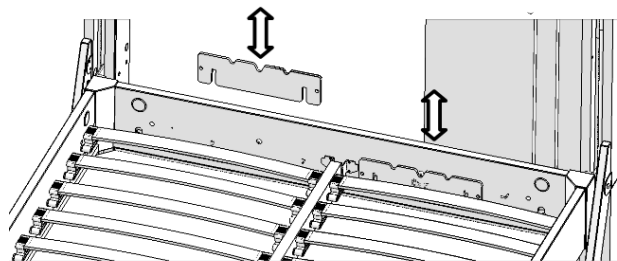

Adjust the weight so that your bed is easy to handle, both on the way up and on the way down.

Case 2: Change of more than 4 kg

We remind you that if you change your mattress, it must not weigh more than 35 kg. Mattresses that are too heavy, with a mechanism or with water, should be avoided!

For a change of bedding weighing more than 4 kg, you'll need to balance the counterweight.

- Secure the bed in the raised position using the locking pins
- Remove the two counterweight cover panels.
- Add or remove 10kg weights or several 2kg weights until balanced.
- Re-scratch your counterweight covers.

If you were to inadvertently remove your mattress without having placed the locking pin, your sleeping surface would rise sharply to the ceiling. In this case, to avoid damaging your JUNO, stand close to the wall structure and push down to lower your sleeping surface. Replace the pin, place your mattress, adjust with the weights and then close the cage with the counterweight covers.

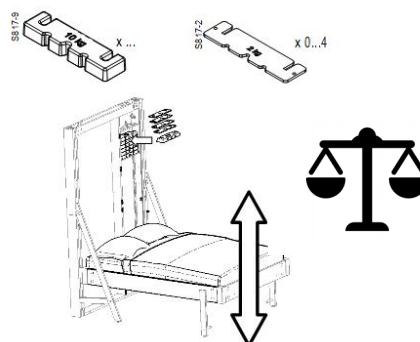
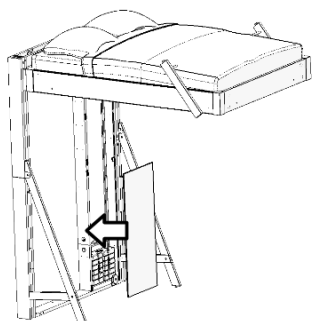

USE

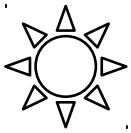

DAY MODE

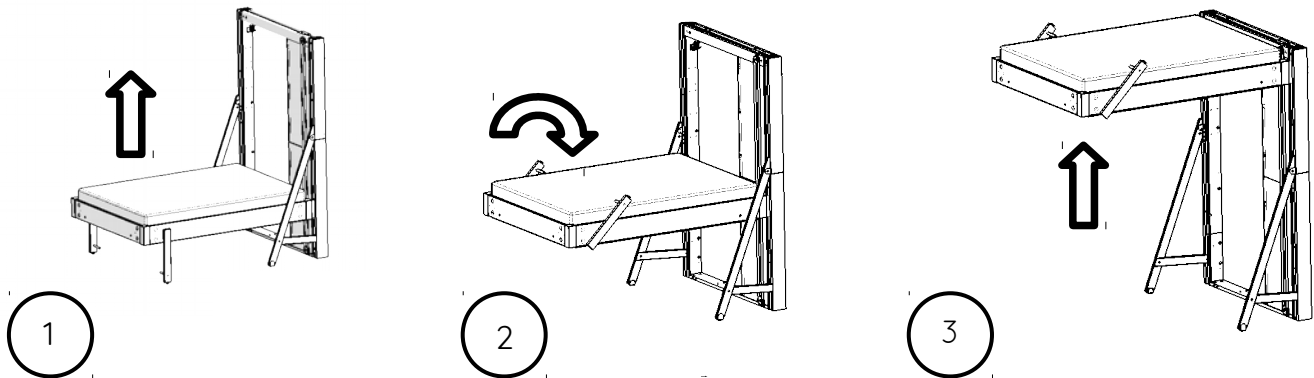

Use the rope to climb out of bed without exerting any force



NIGHT MODE

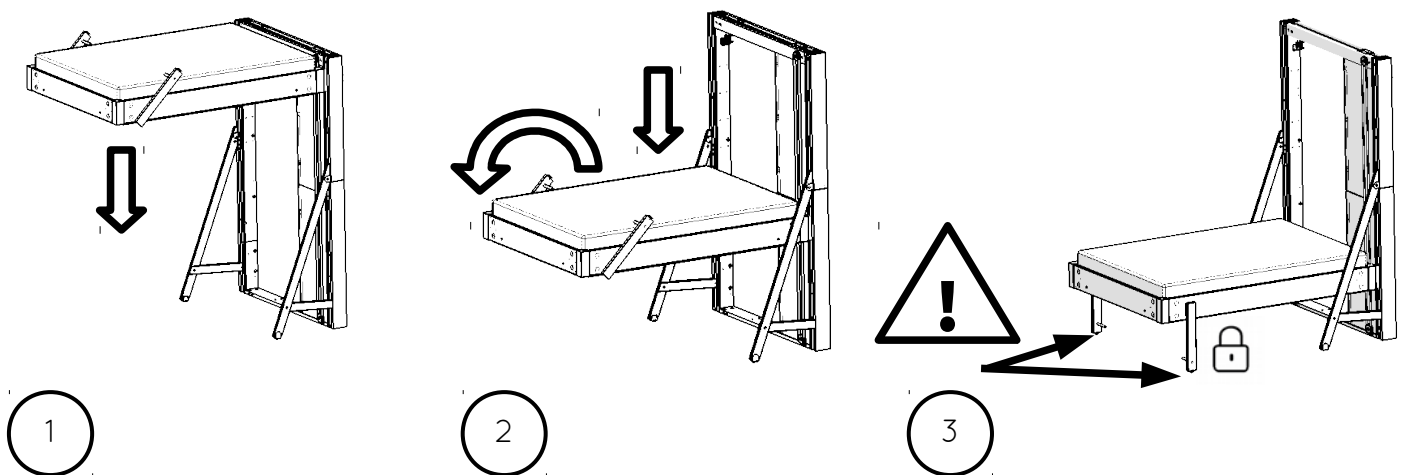

Always unfold the bed legs to the lowest position before sitting or sleeping. Don't forget to pass this information on to all bed users.

Secure the bed legs with the pins; the angle between the frame and the foot of the bed must be 90°. Do not handle the bed when someone is standing underneath it and take care when lowering the legs too.

Do not put any sharp objects under the bed and make sure that no object is higher than the feet of the bed.

Start lowering the bed using the rope, you can then lower the bed frame directly, lowering the frame by positioning yourself as close as possible to the wall structure.

As with balancing the bed, always remember to lock the bed frame in the lowered position using the locking pins when removing bedding items (duvets, pillows, etc.).

UNPACKING:
follow the instructions
step by step

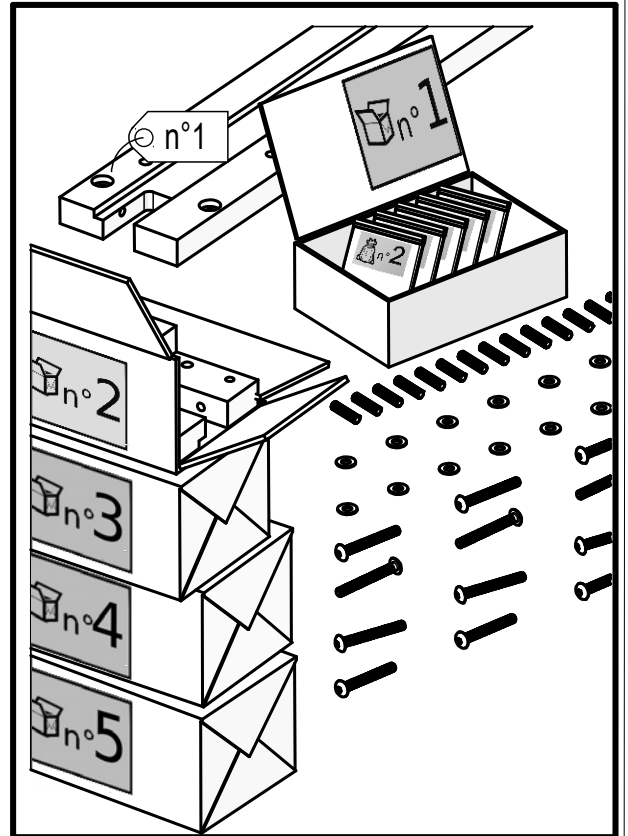
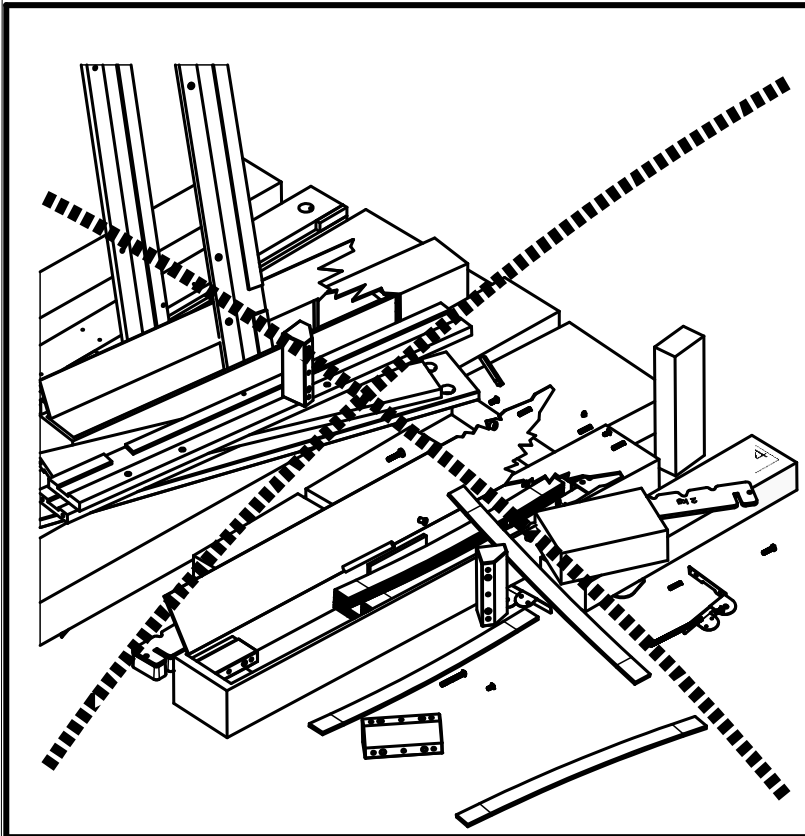

COUNTER WEIGHT :
Right or Left

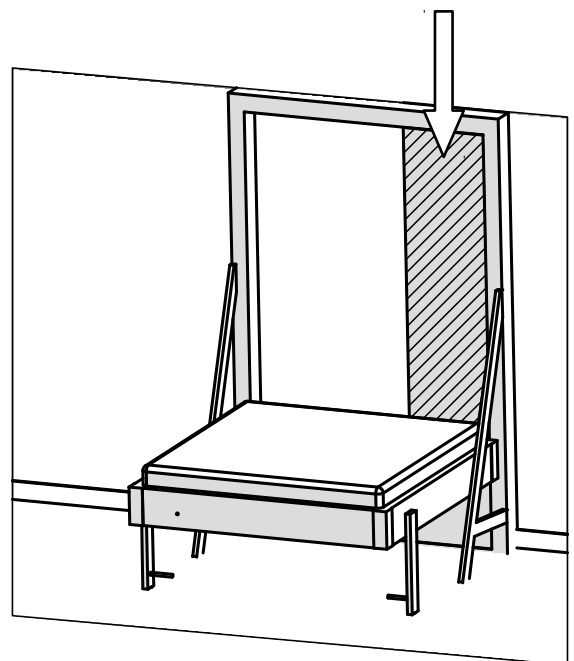
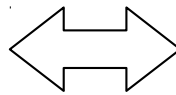
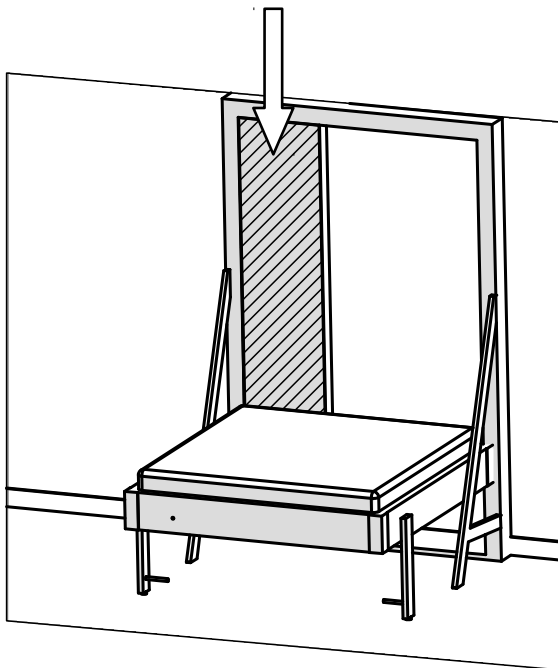

FIND OUR ASSEMBLY TIPS ON MAFAEL.COM

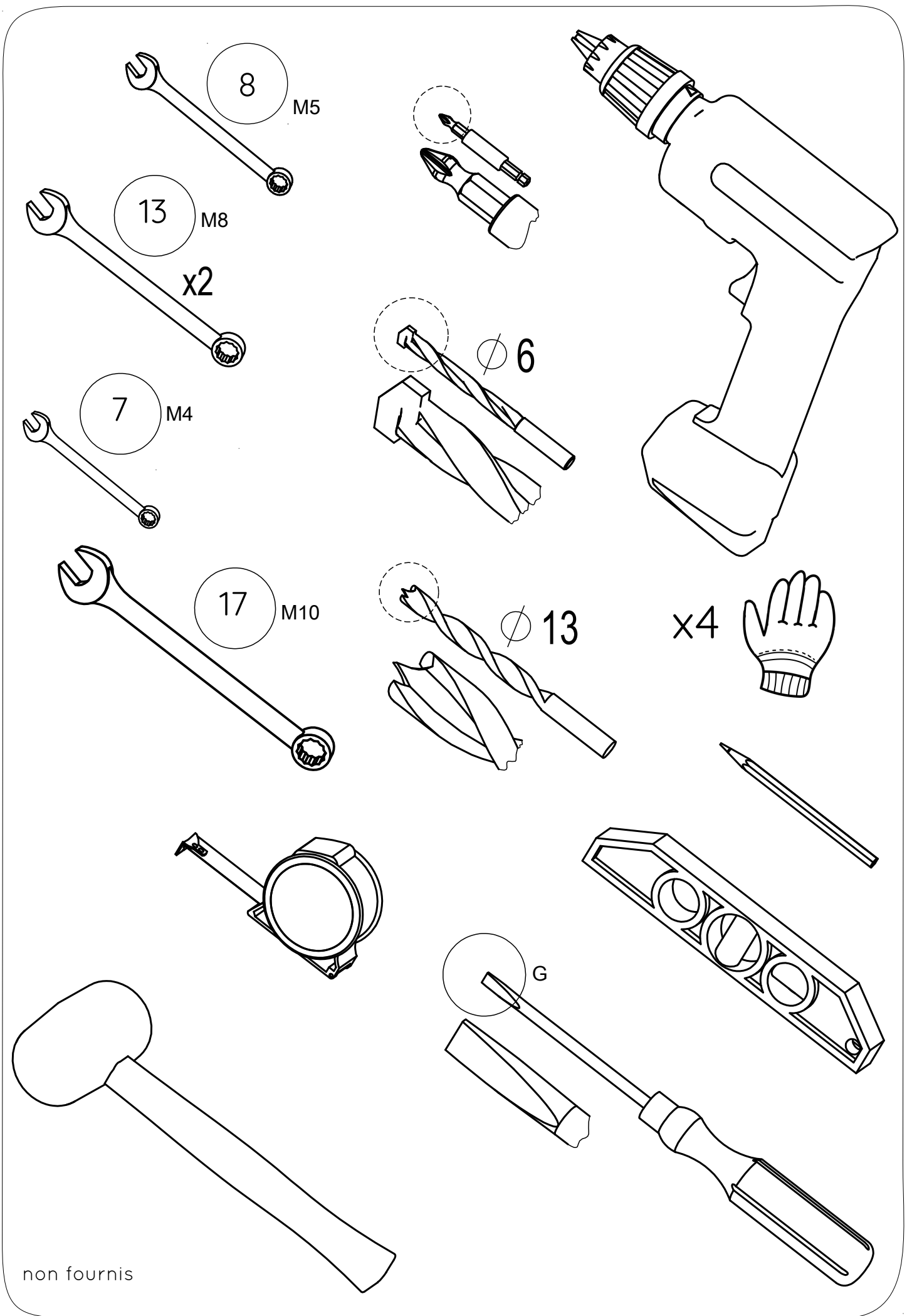

non fournis

 n°1

 n°2

 n°3

 n°4

 n°5

 n°6

 n°7

 n°8

 n°9 x 7

 n°10

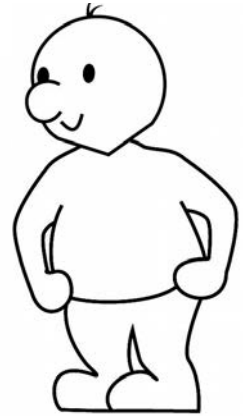
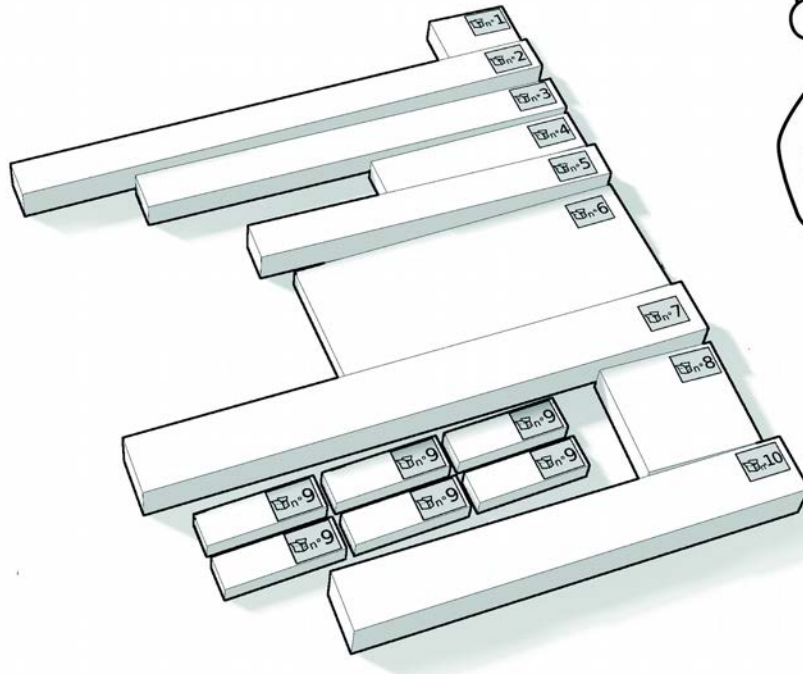

 n°1

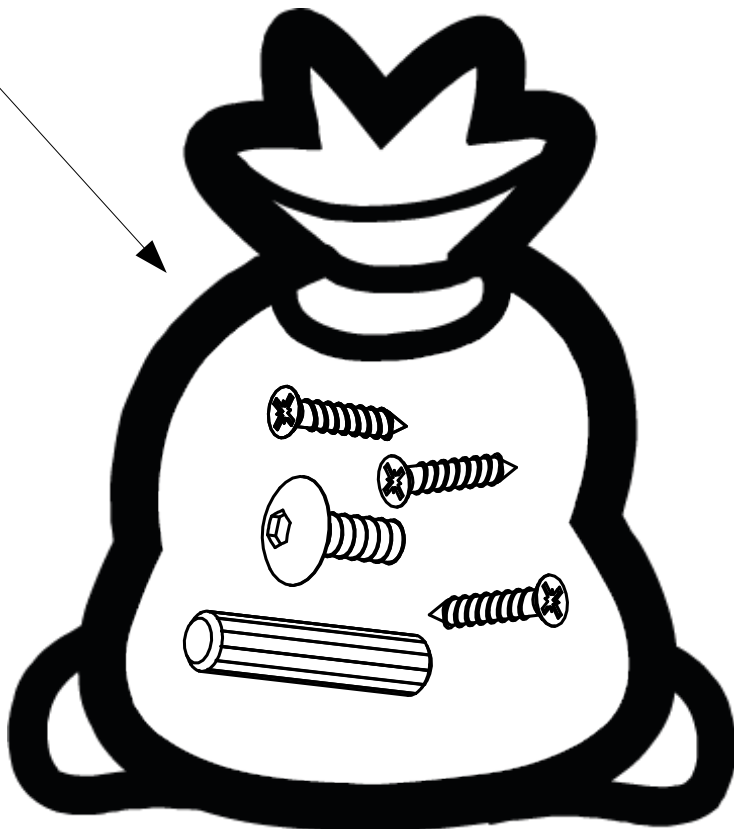

 n°1

 n°2

 n°3

 n°4...

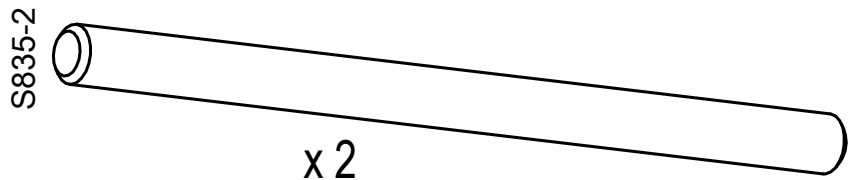
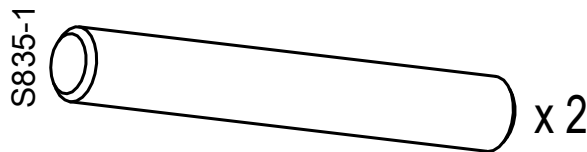
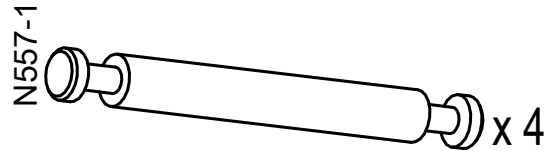
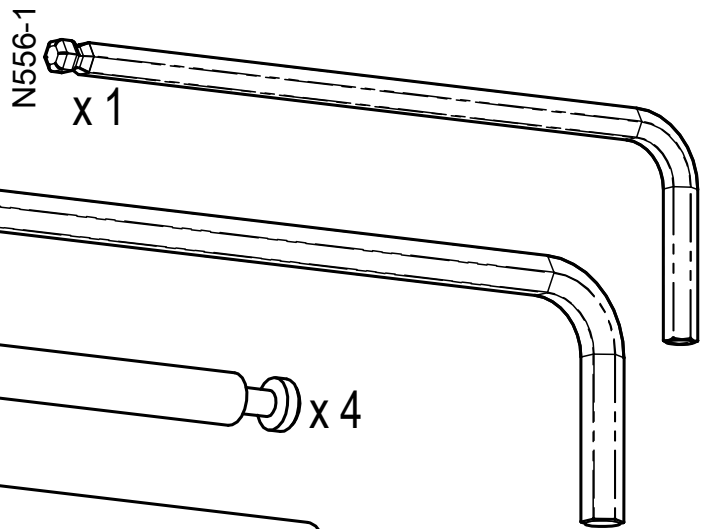
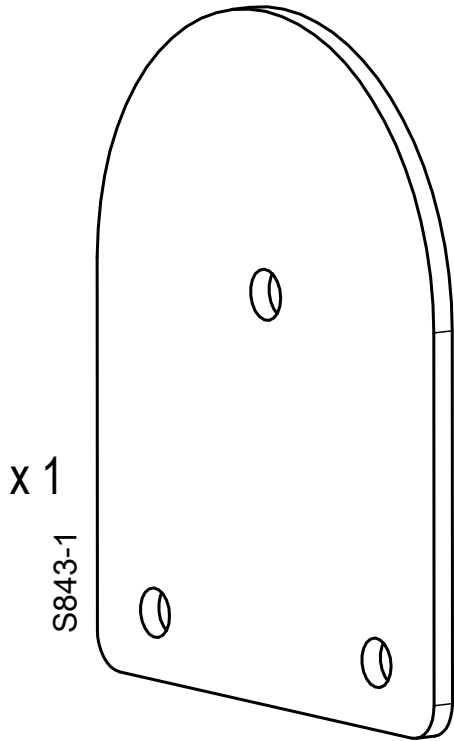
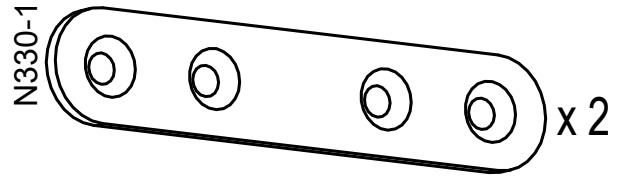
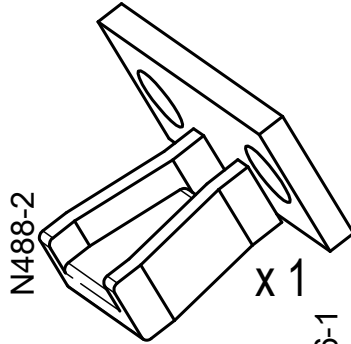
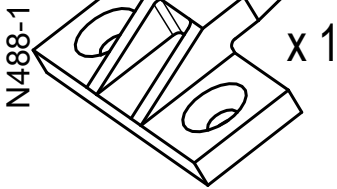
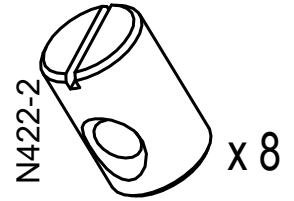
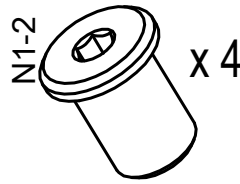
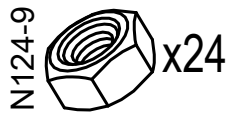
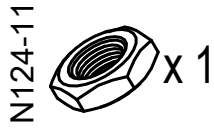
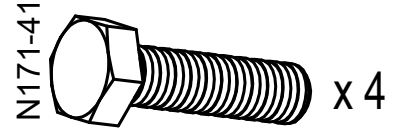
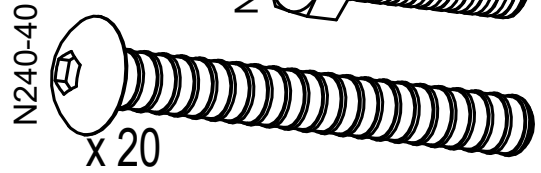
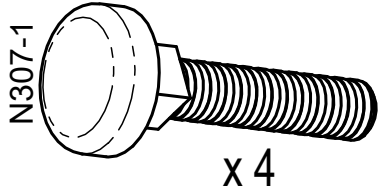
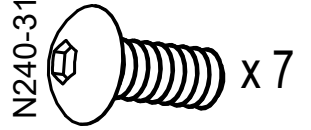
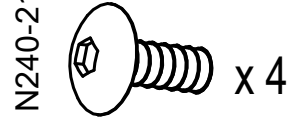
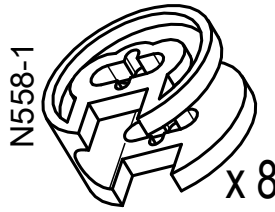
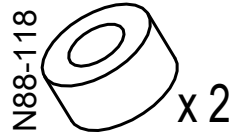
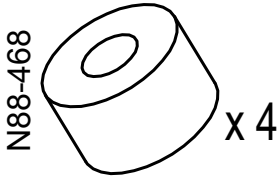
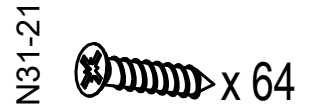
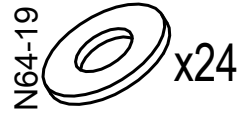



n°2

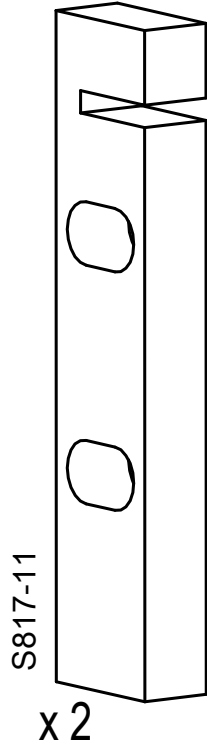

S817-11

x 2

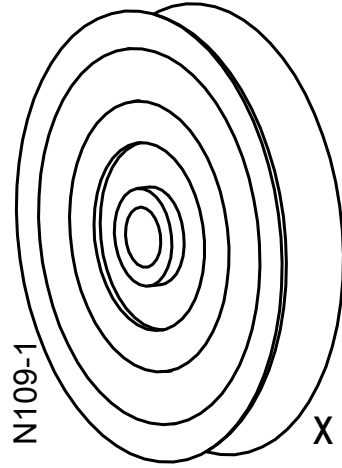

N109-1

x 2

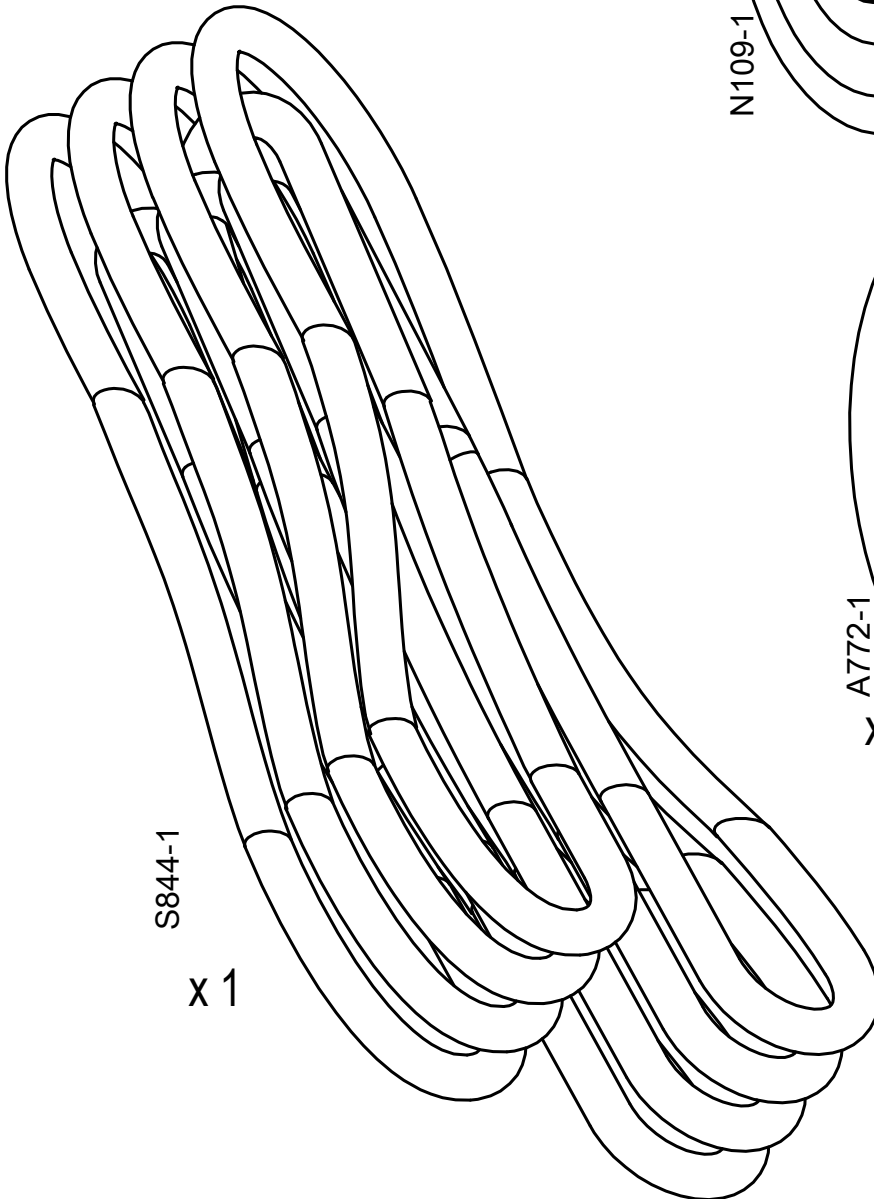

S844-1

x 1

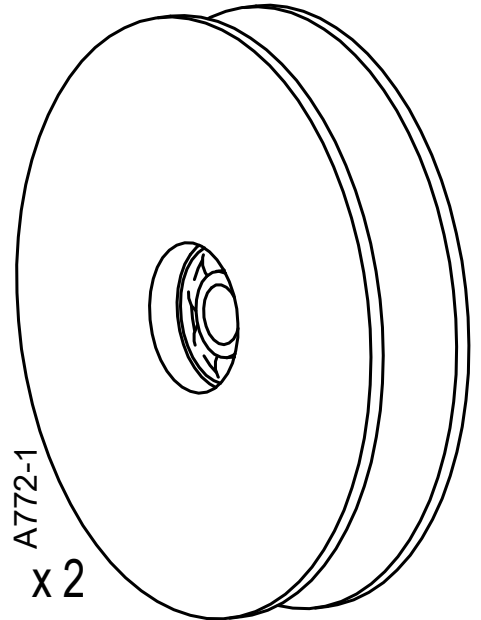

A772-1

x 2



n°3

X 1
N546-4

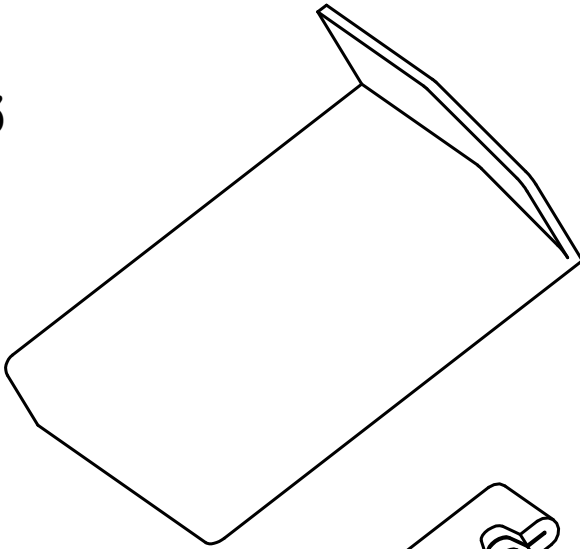

N546-2

x 1

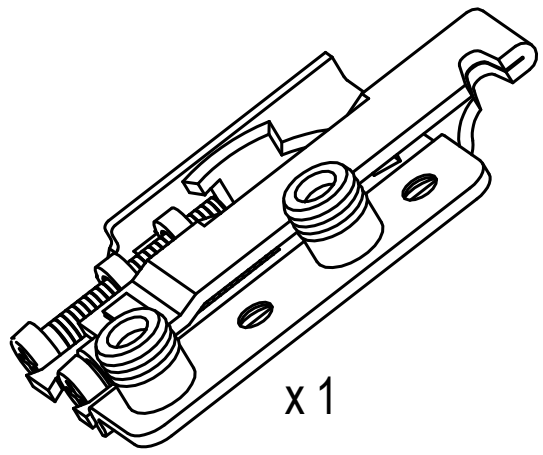

X 1
N546-1

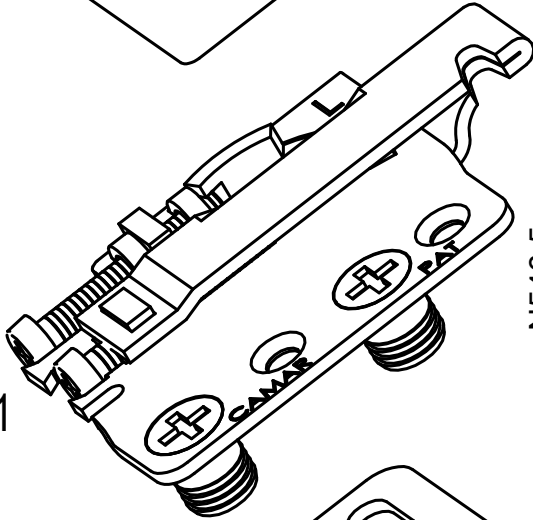

N546-5

x 1

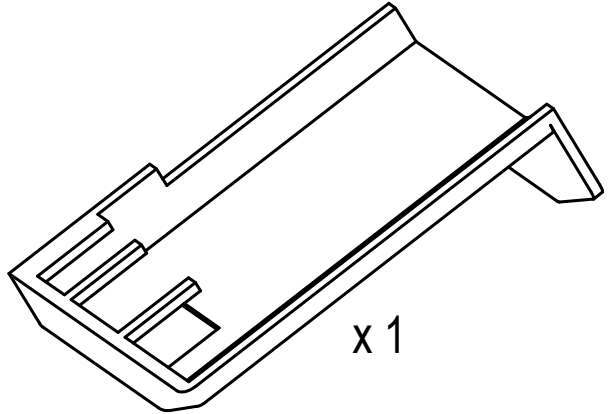

N546-3

x 2

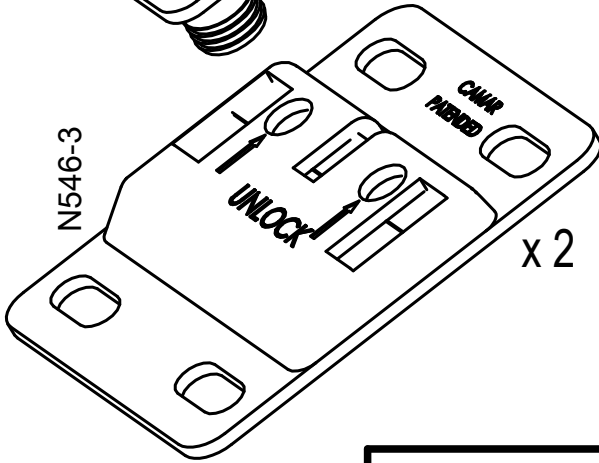

N553-2



x 8

N64-11



x 8

N552-3

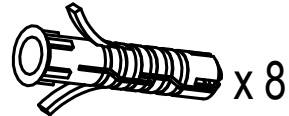

x 8



n°4

A724-1

x 1

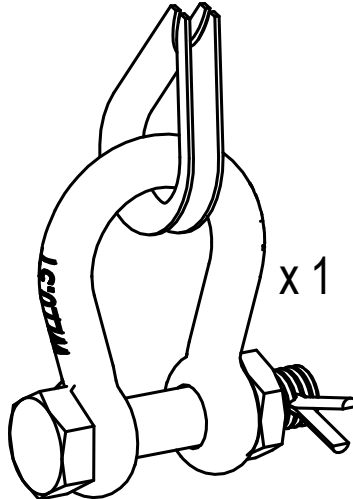

A177-1

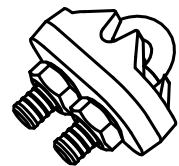

x 2



n°5



N24-6

x 31

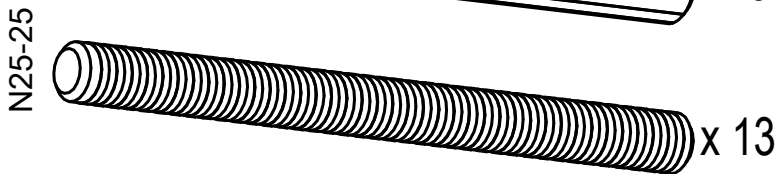

N25-25

x 13

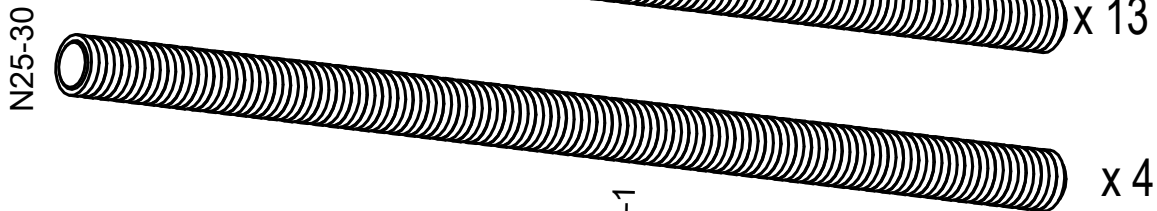

N25-30

x 4

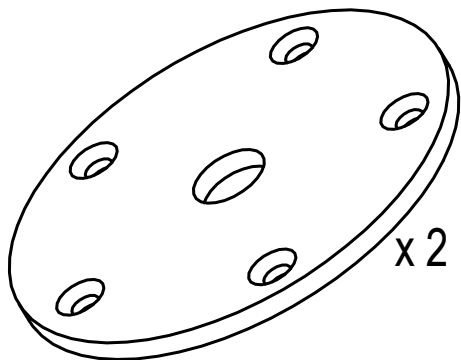

S849-2

x 2

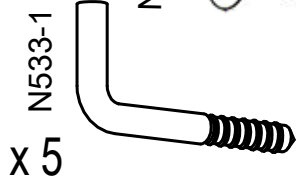

N533-1
x 5



N561-1

x 8

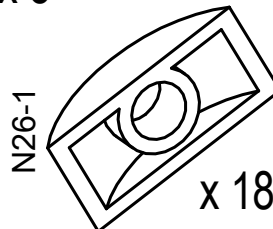

N26-1

x 18



n°6

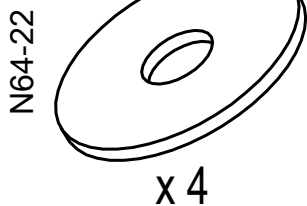

N64-22

x 4



N124-14

x 2

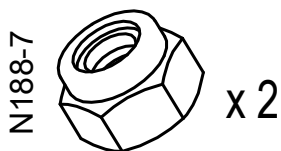

N188-7

x 2

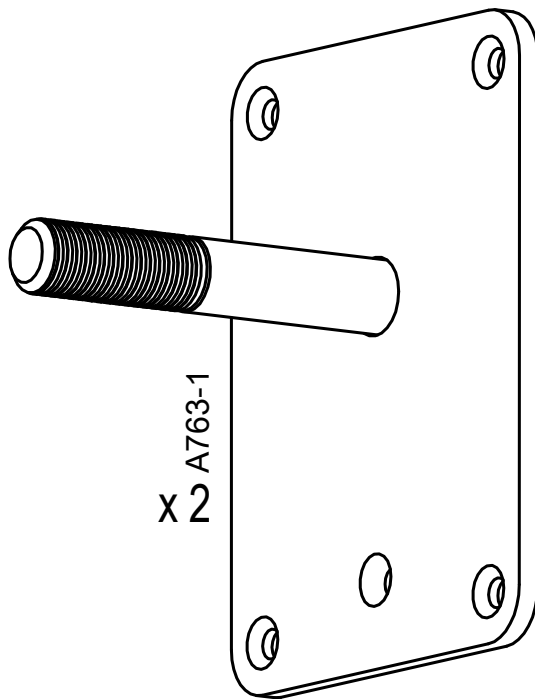

A763-1
x 2

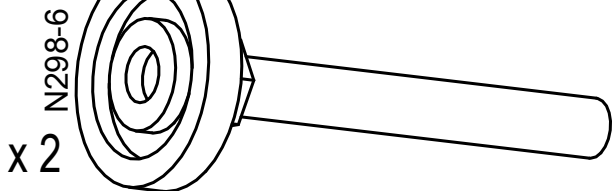

N298-6
x 2

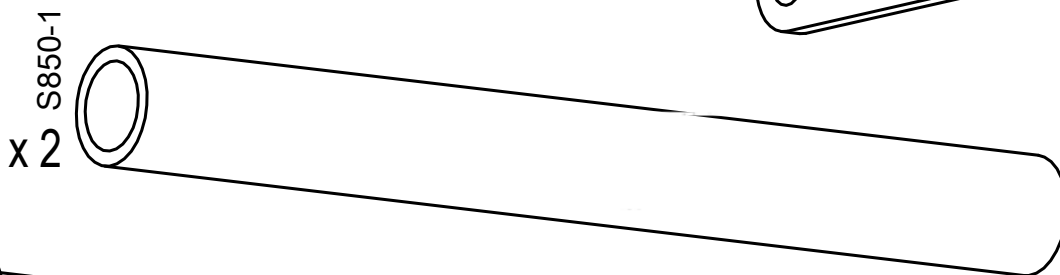

S850-1
x 2

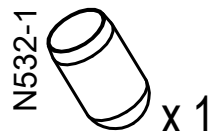
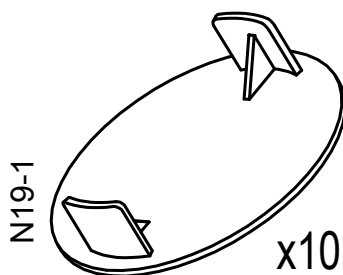
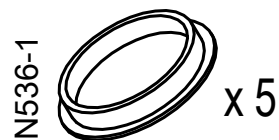
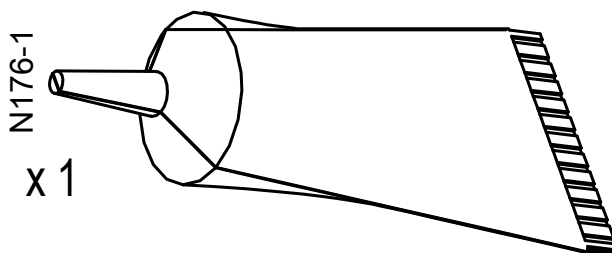
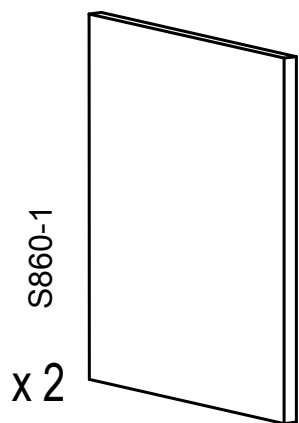
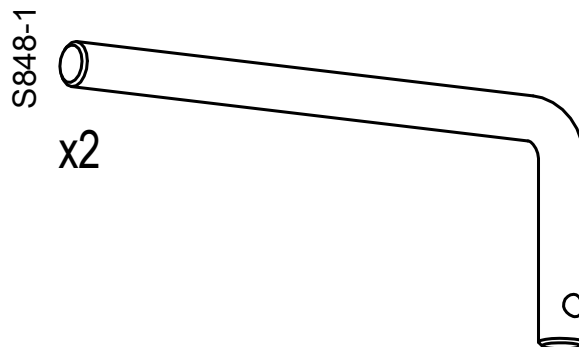
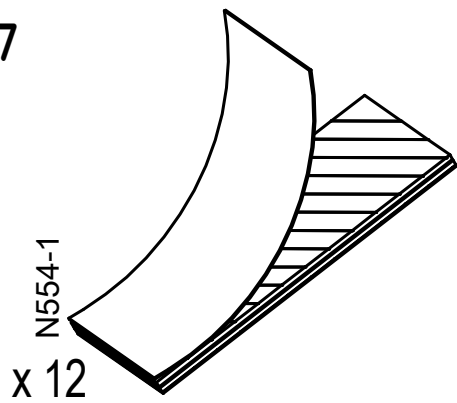



n°1

N237-1

x 4

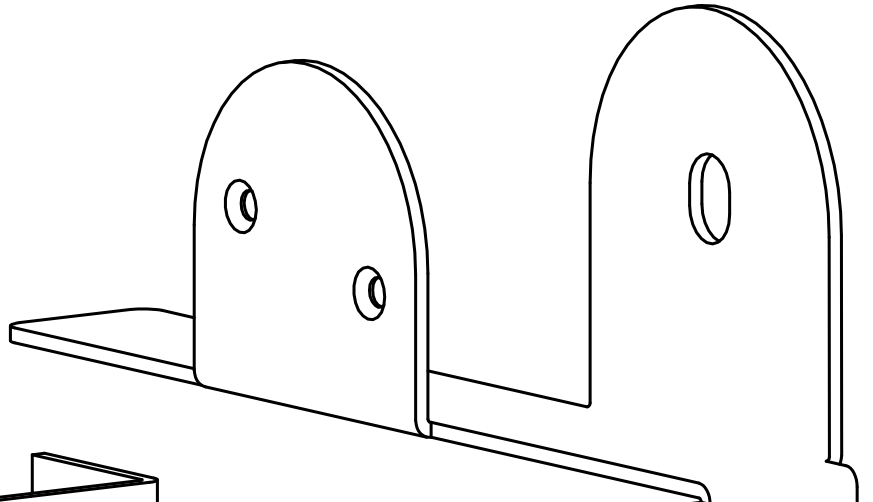

x 2

S829-1

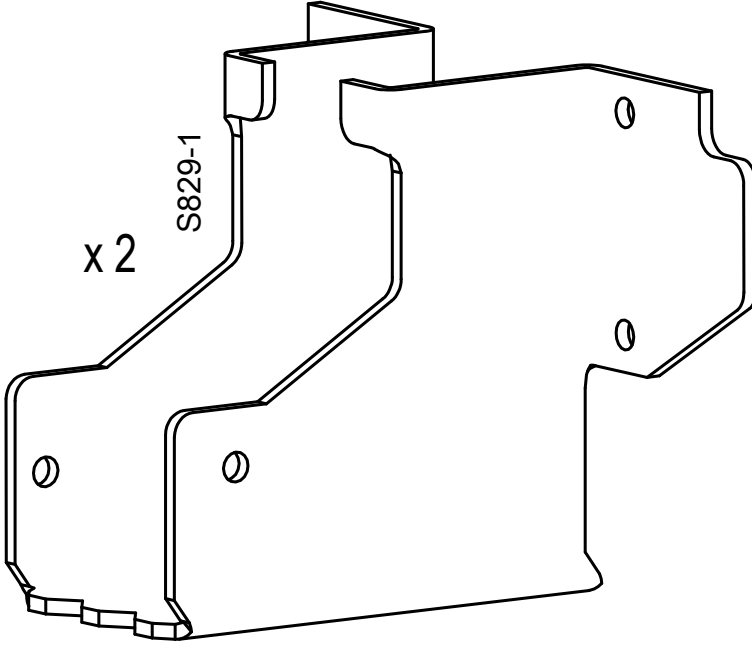

S832-2

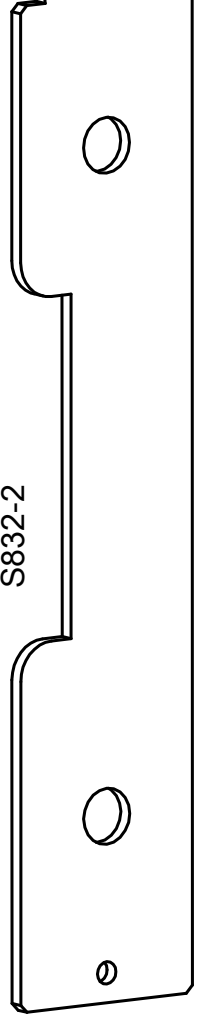

x 2

S845-1

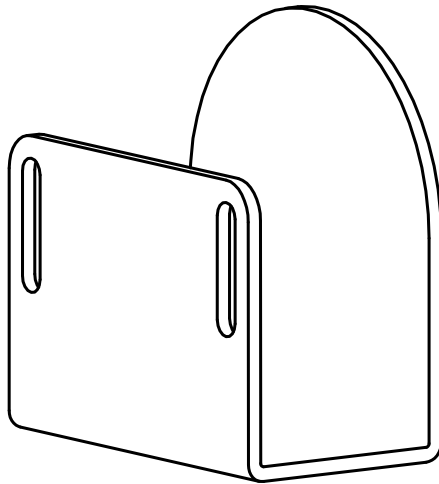

S832-1

x 1

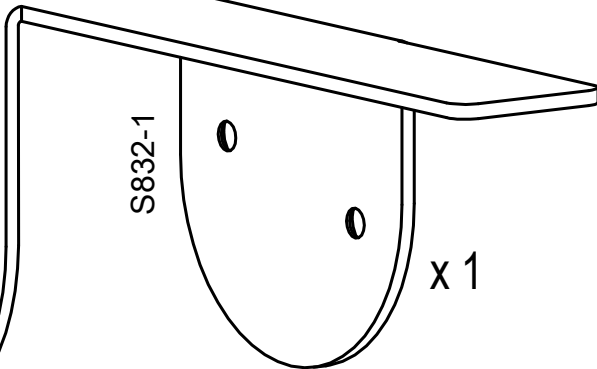

S864-1

x 1

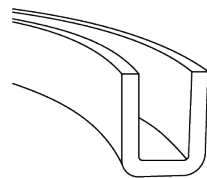

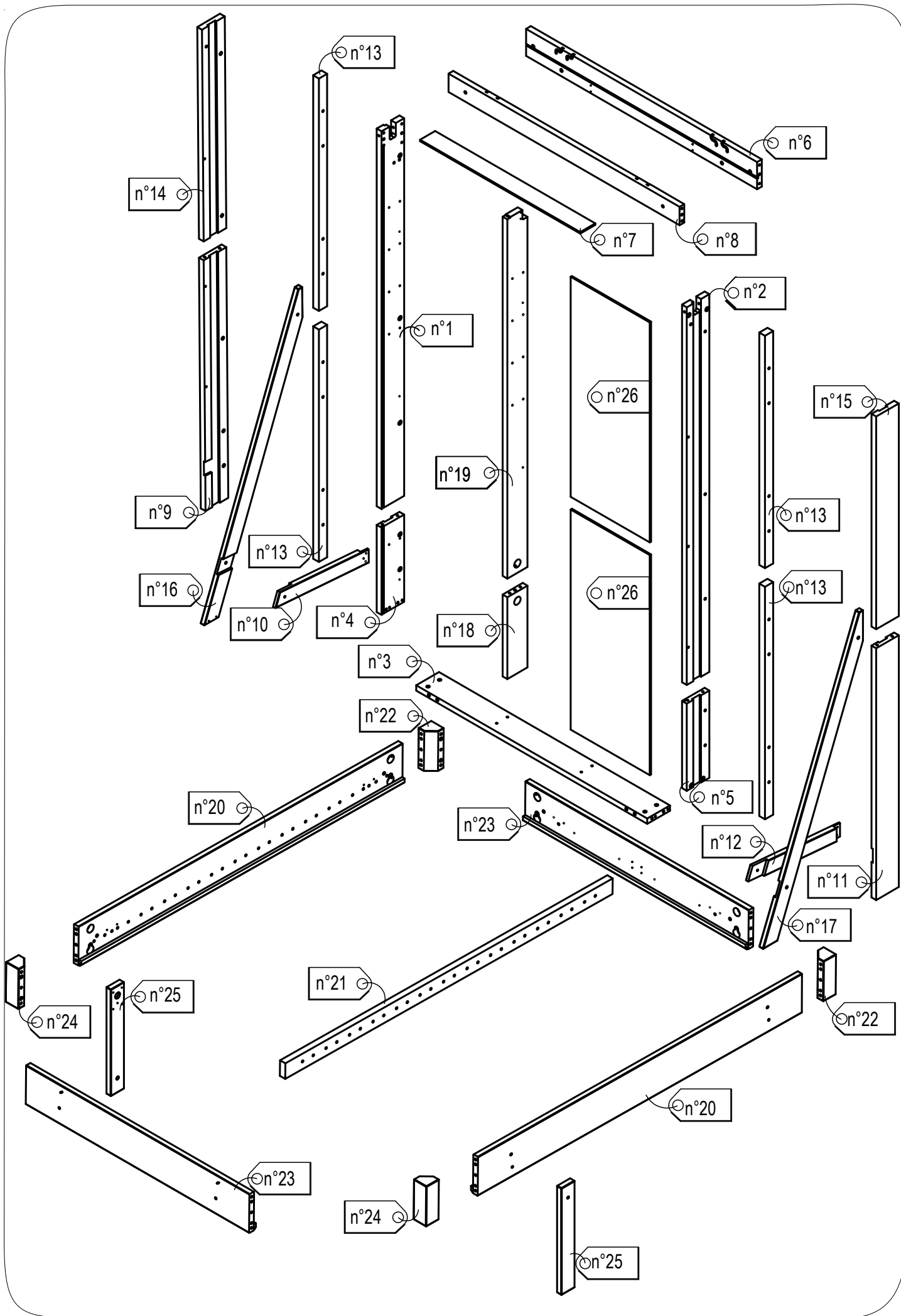

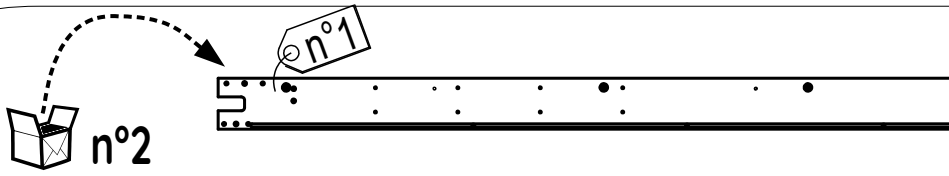

n°1

N88-468



x 2

S835-2

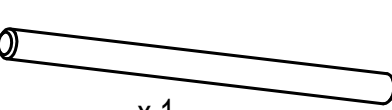

x 1

n°8

N321-2



x 1

n°2

N109-1

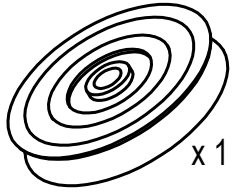

x 1

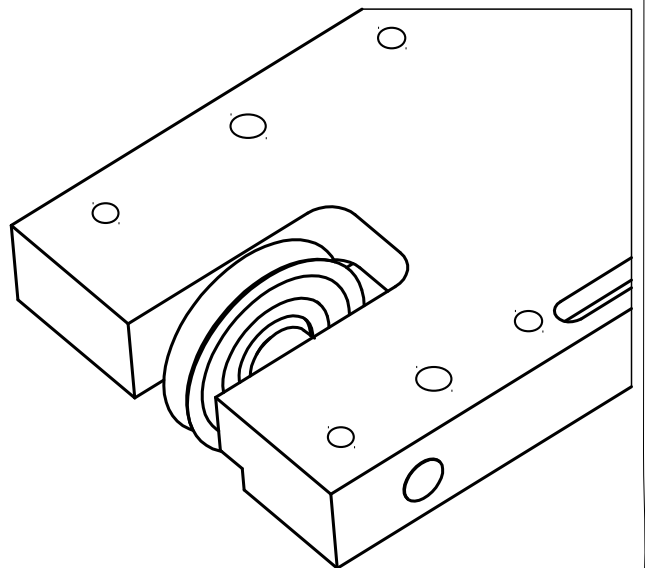
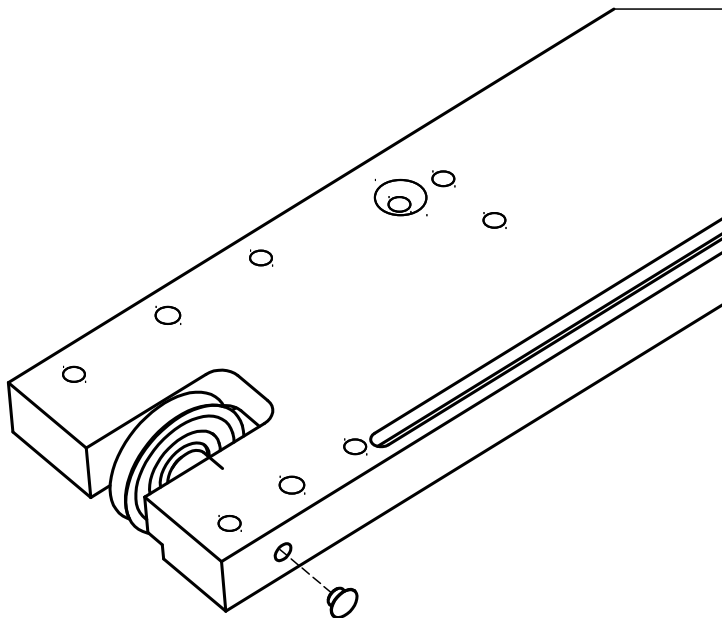
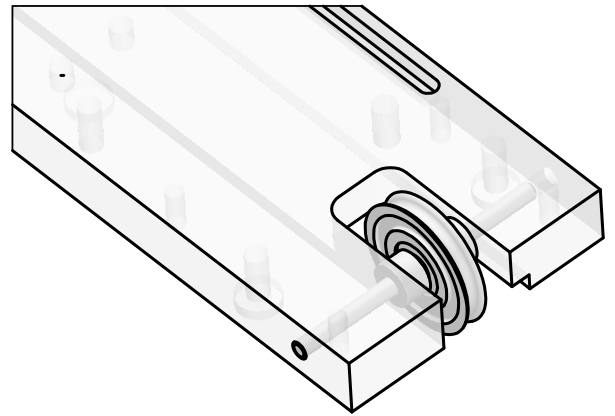
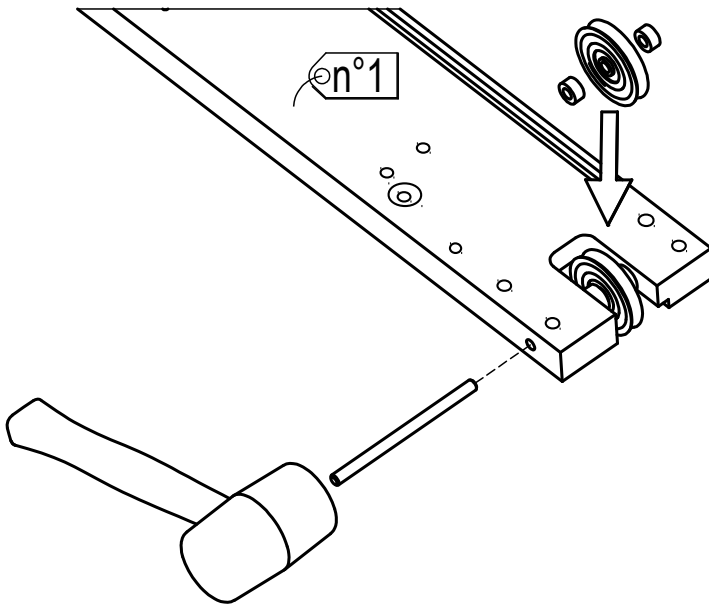

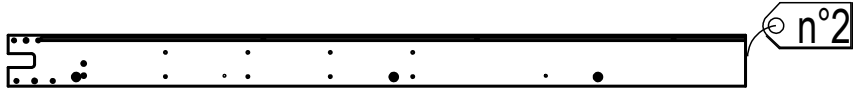

N88-468



x2

S835-2

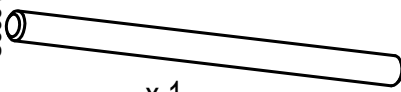

x1



n°8

N321-2



x1



n°2

N109-1



x1

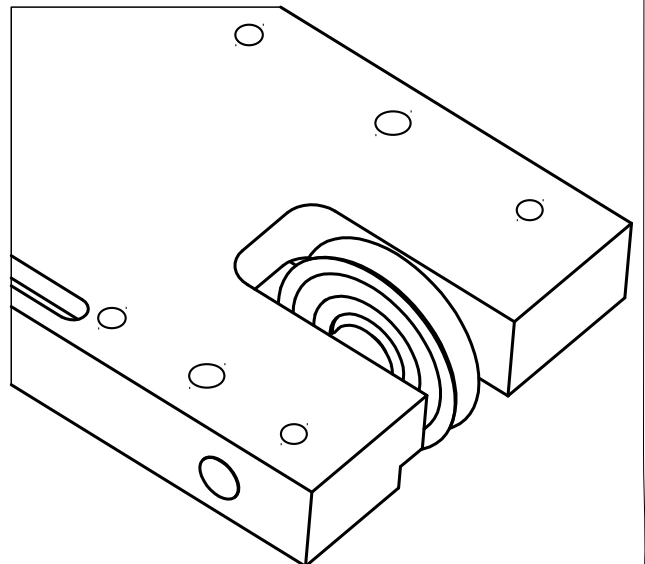
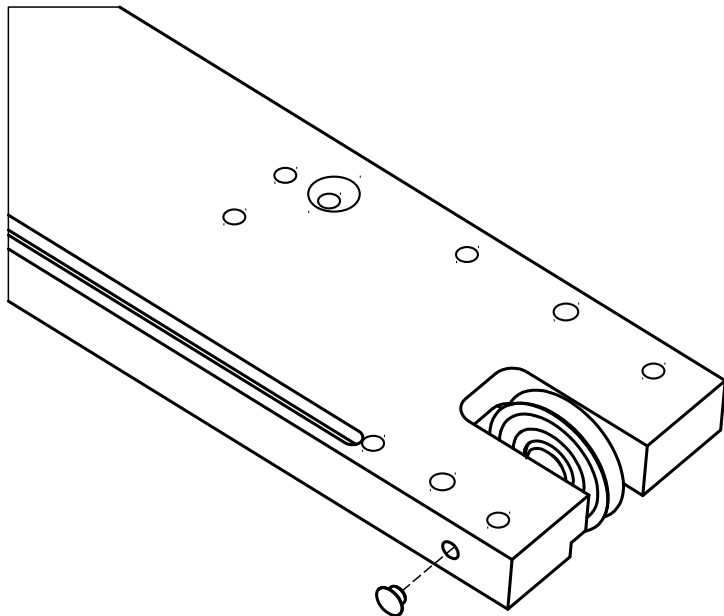
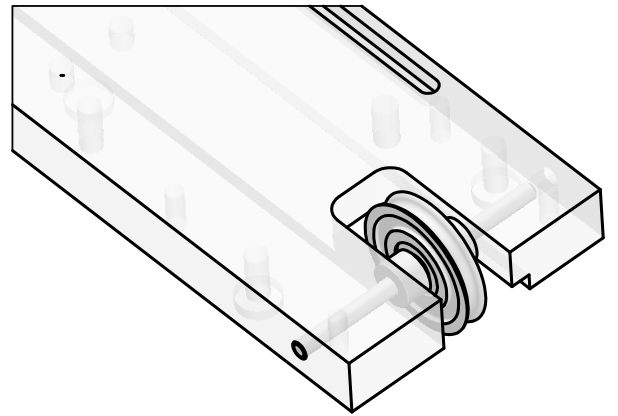
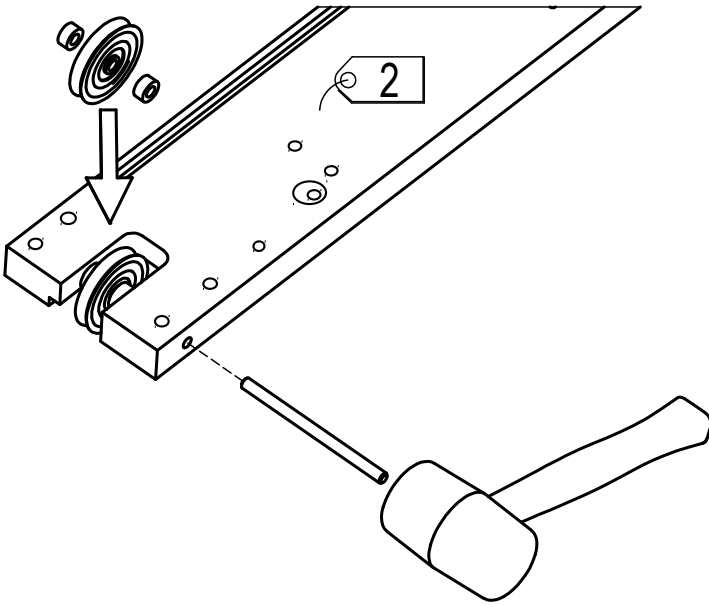

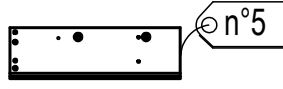
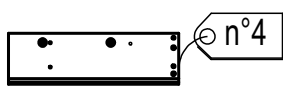
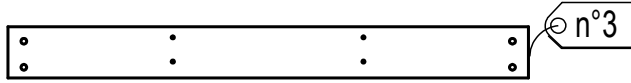

N24-8

x 4

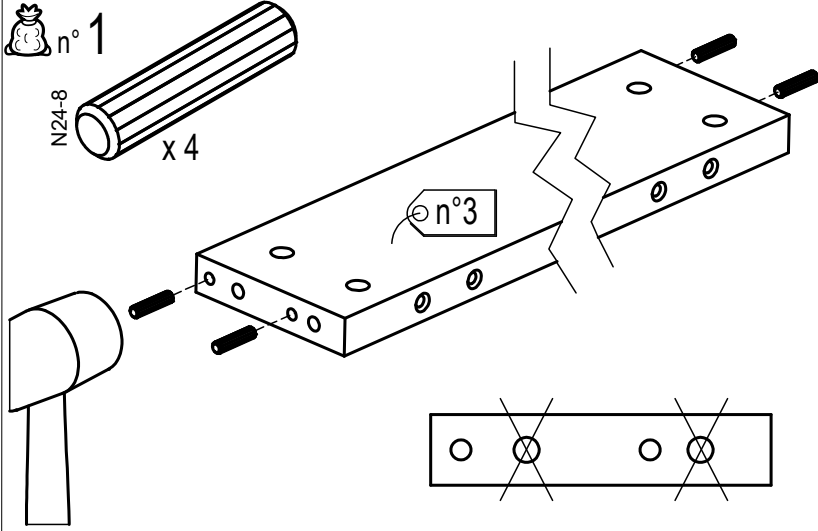

N422-2

x 4

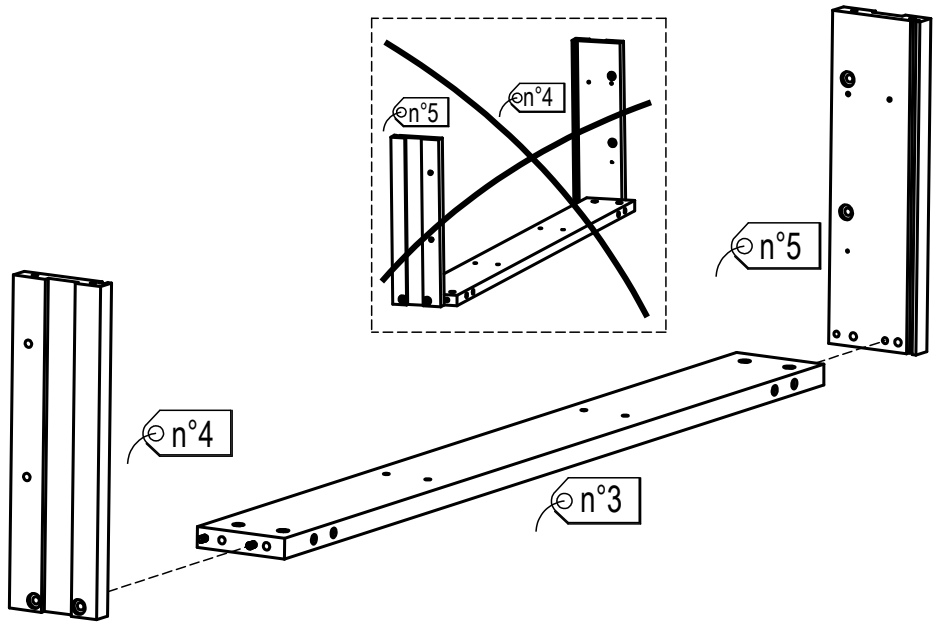
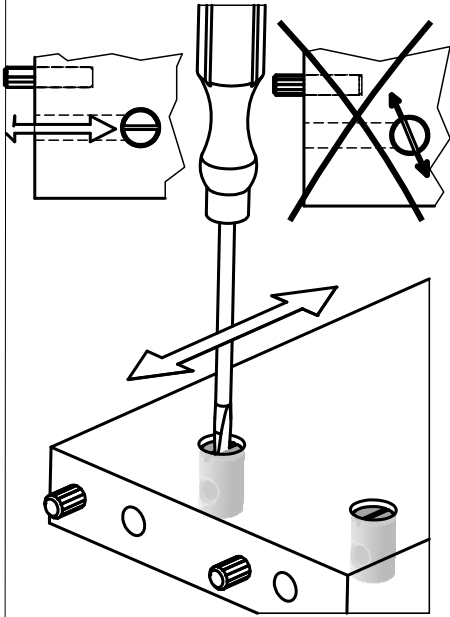
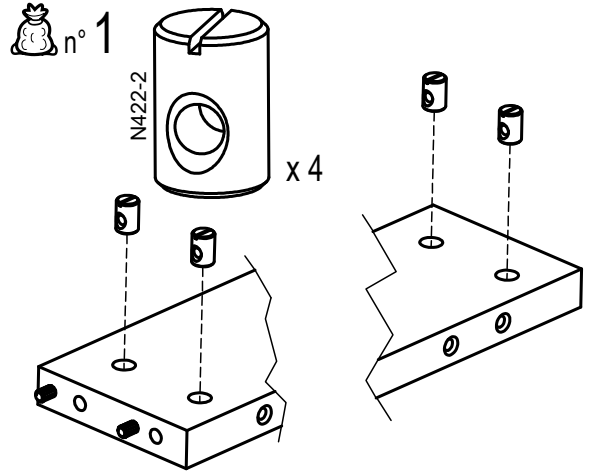

N24-8

x 4

N240-40

x 4

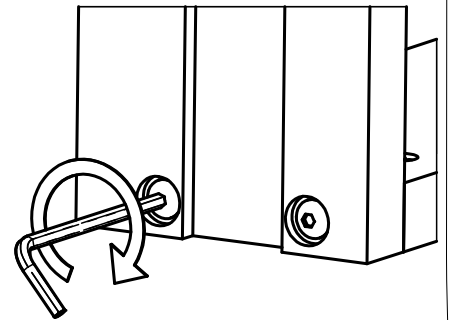
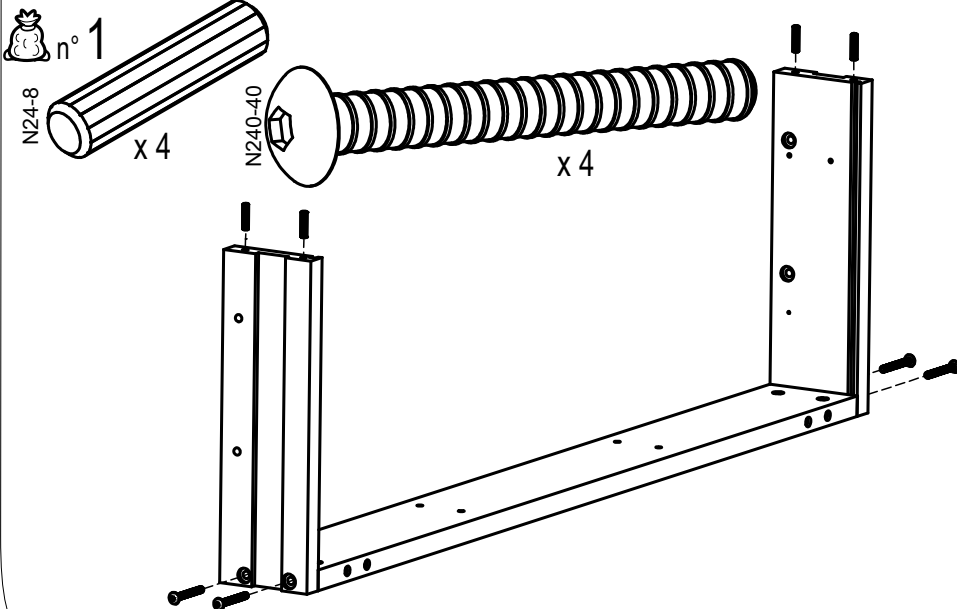

 n°1

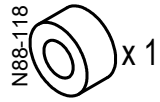
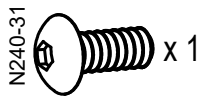

 n°2

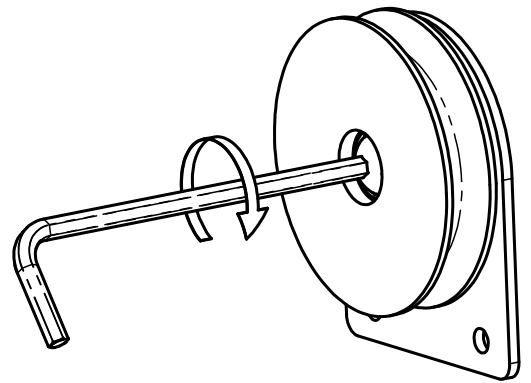
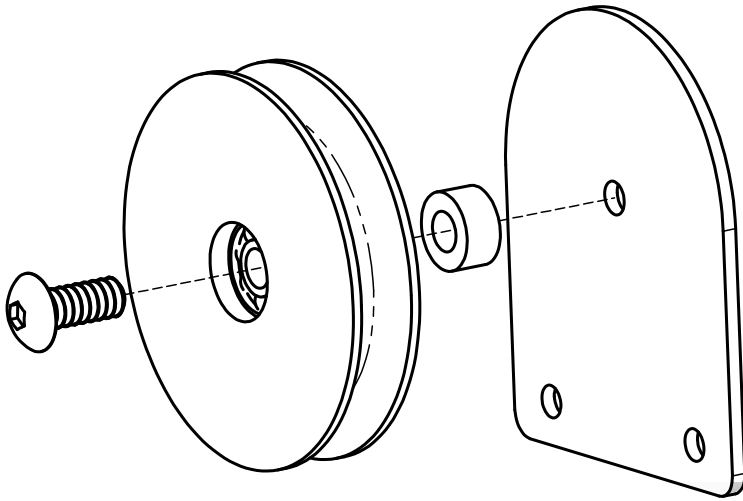
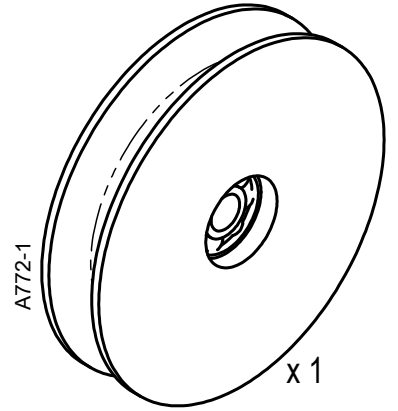
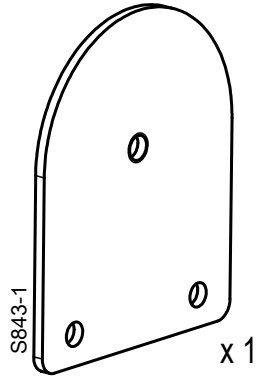

 n°1

N124-11 x 1

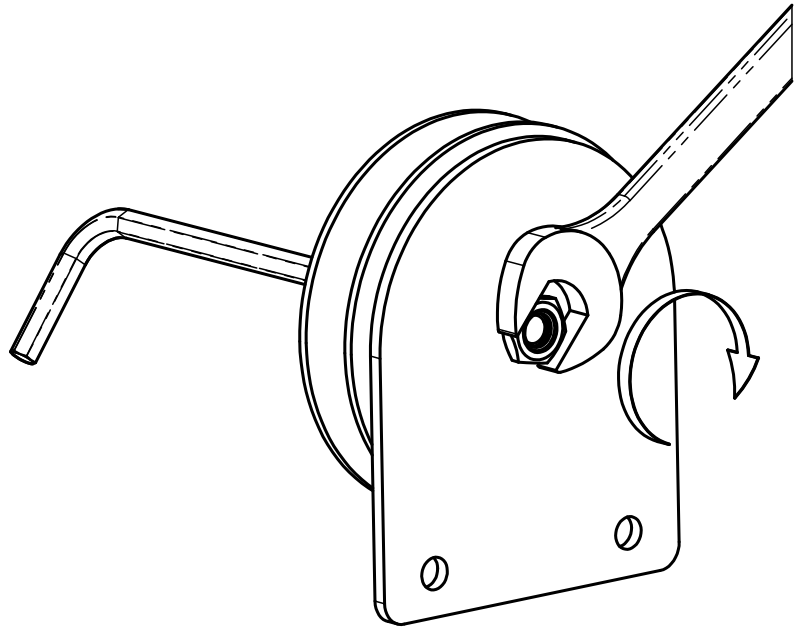
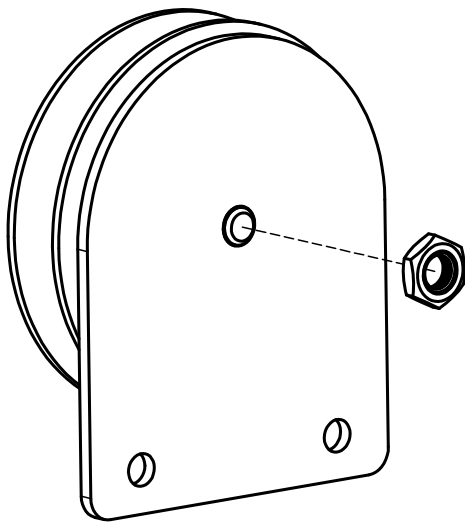

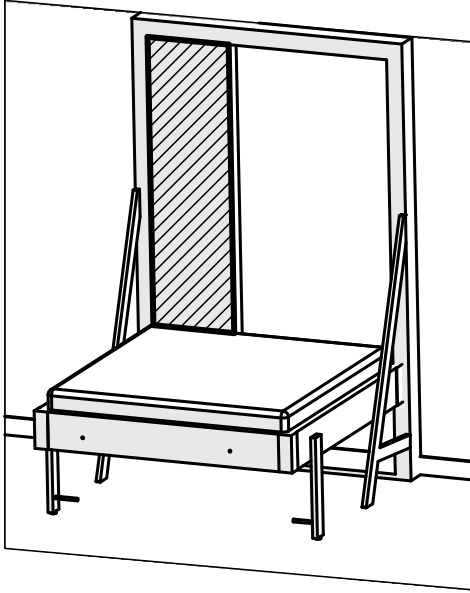

VS

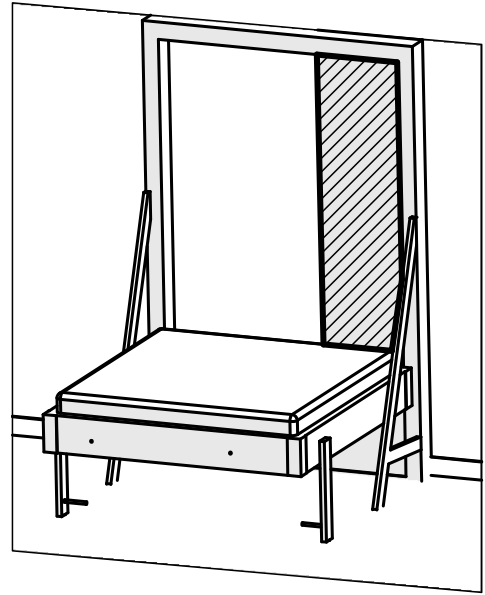

Choisissez
accès facile > contrepoids

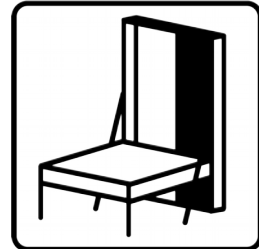

no 1

N240-21 x 2



VS

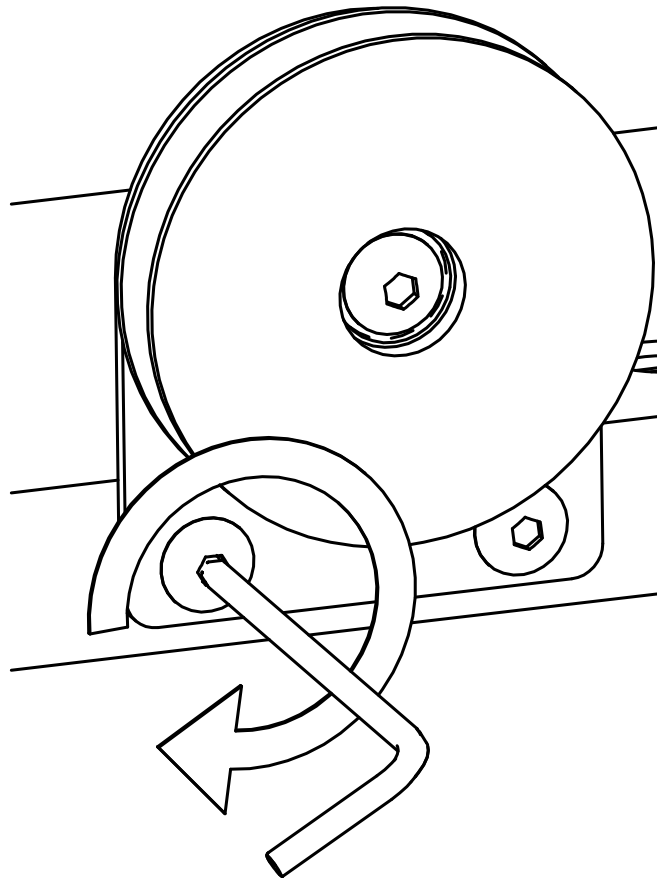
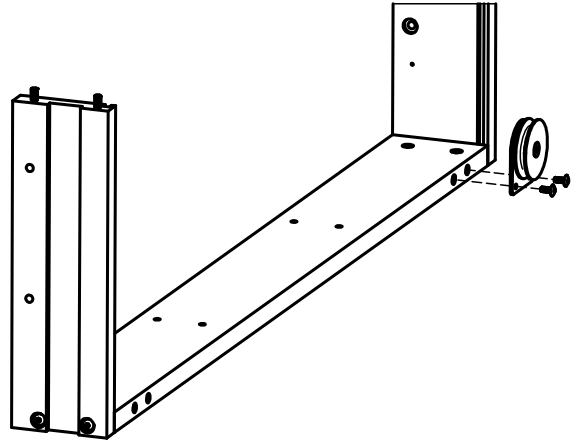
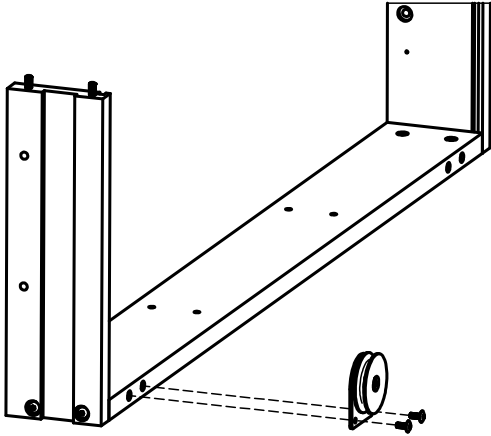
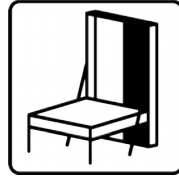

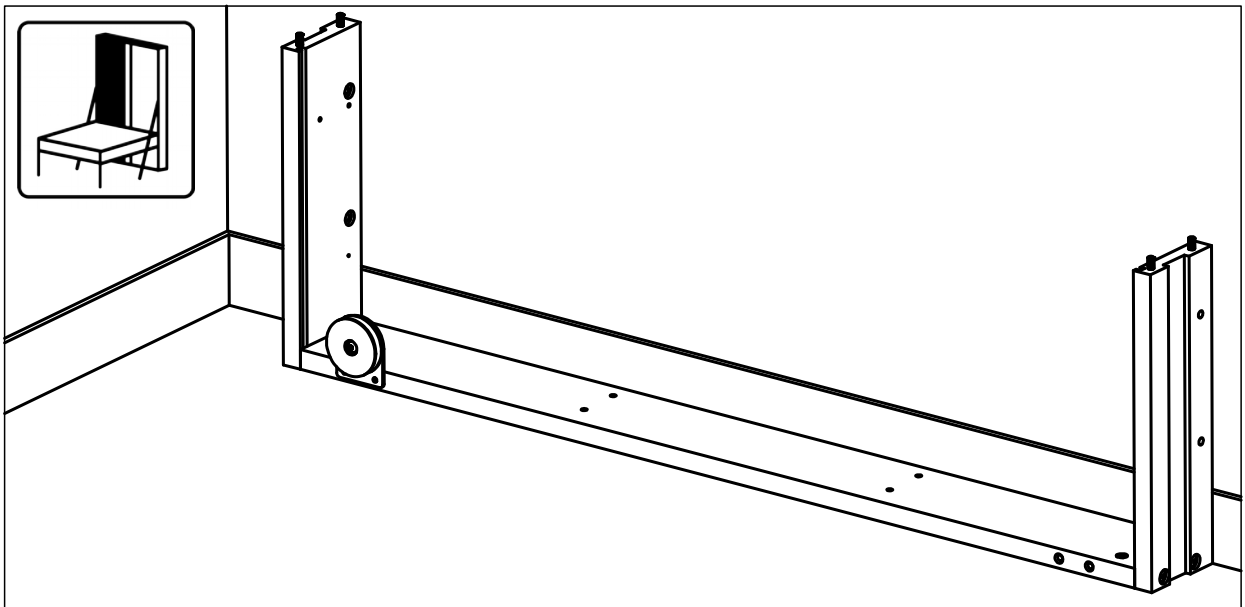
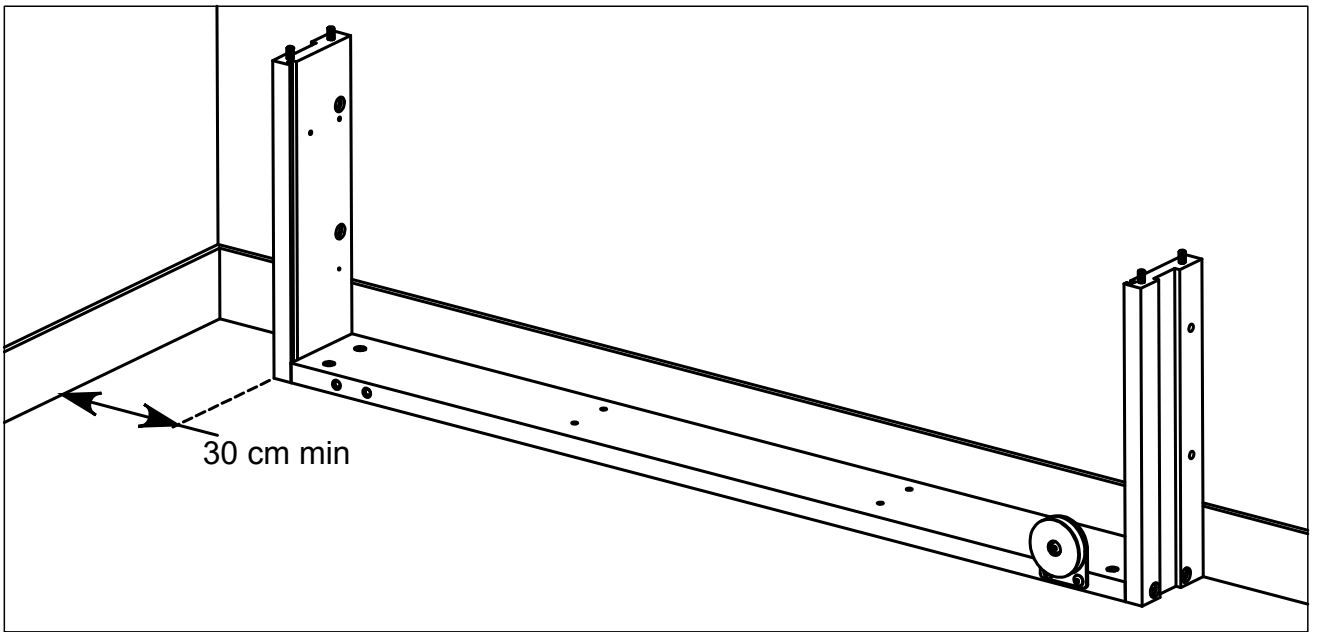
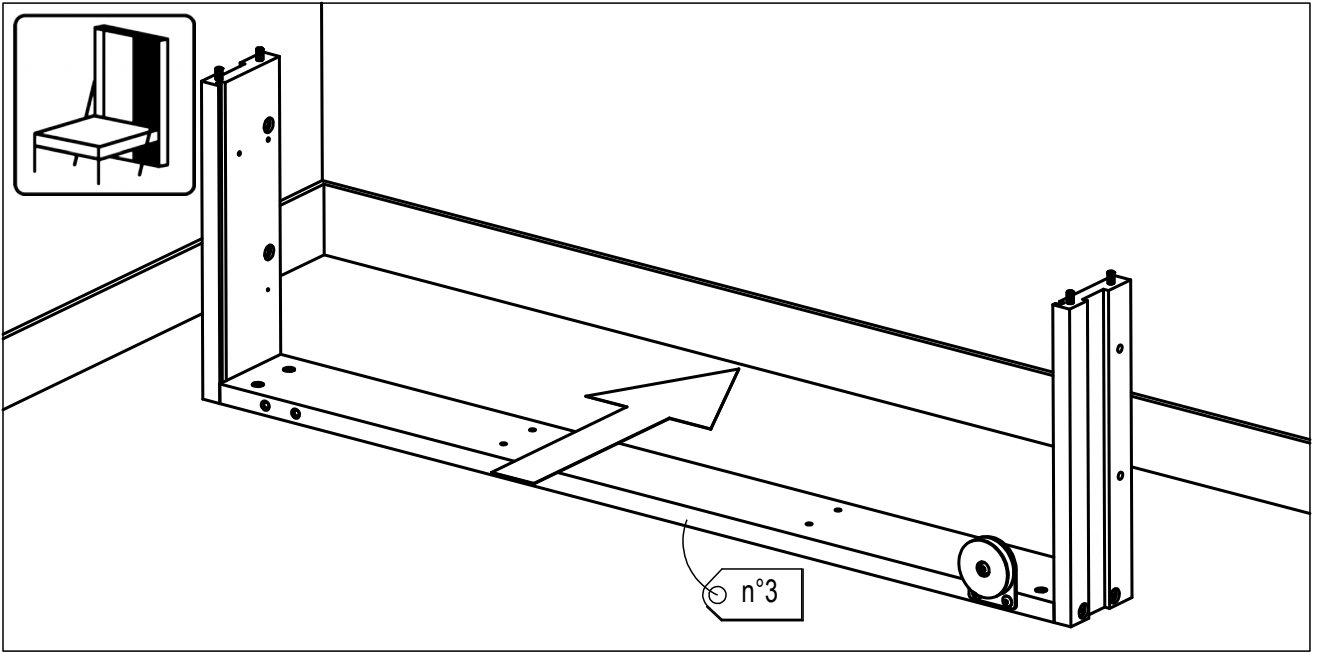

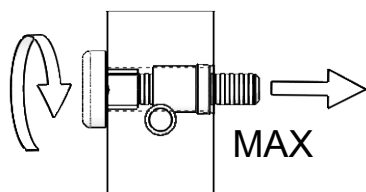
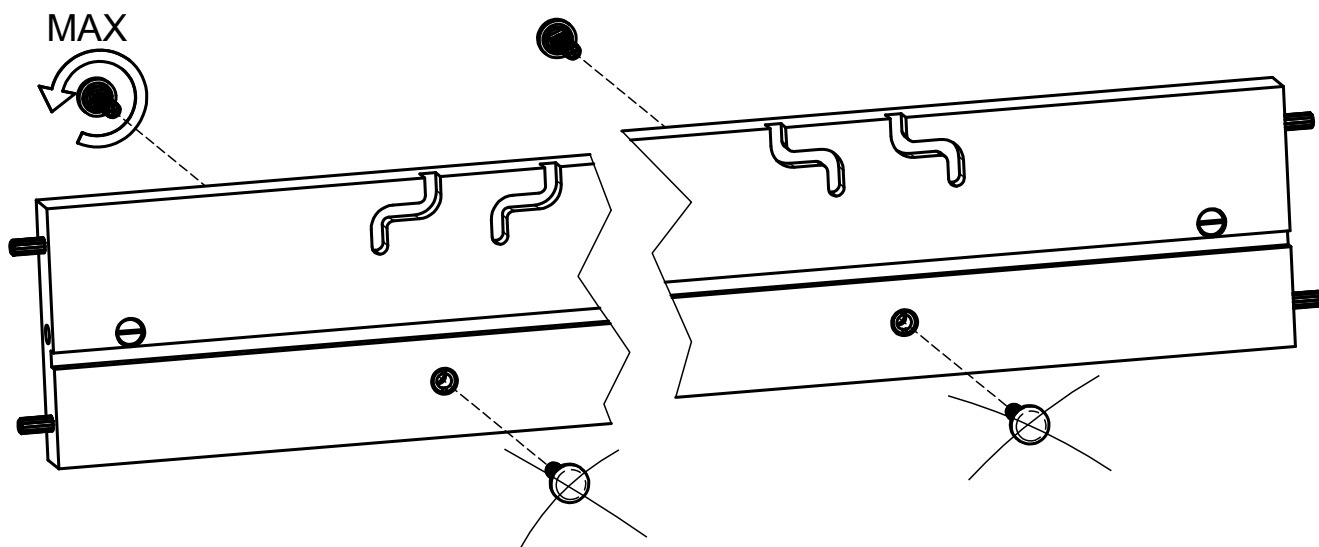
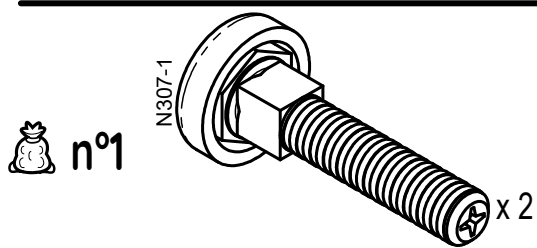
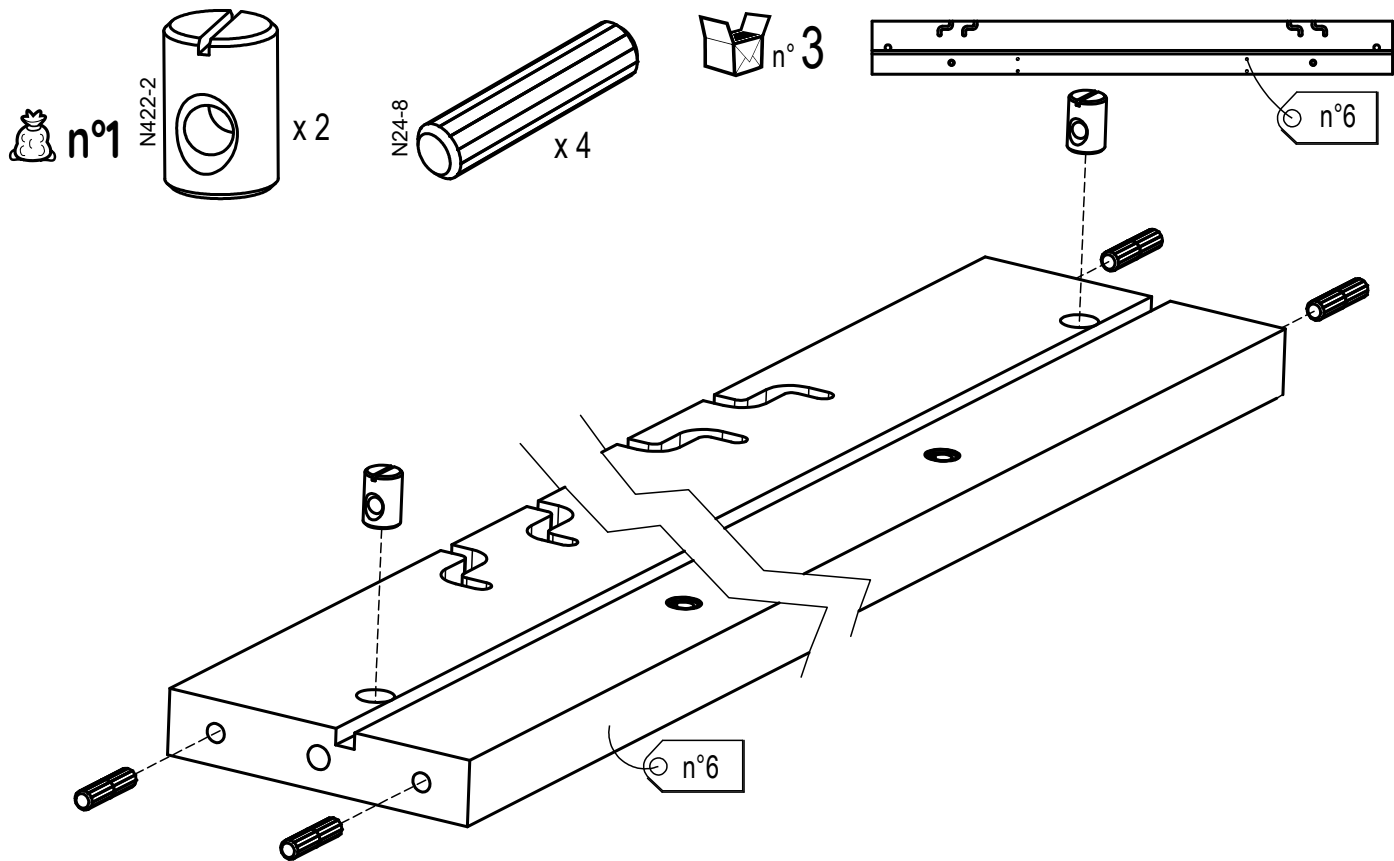

 n°1

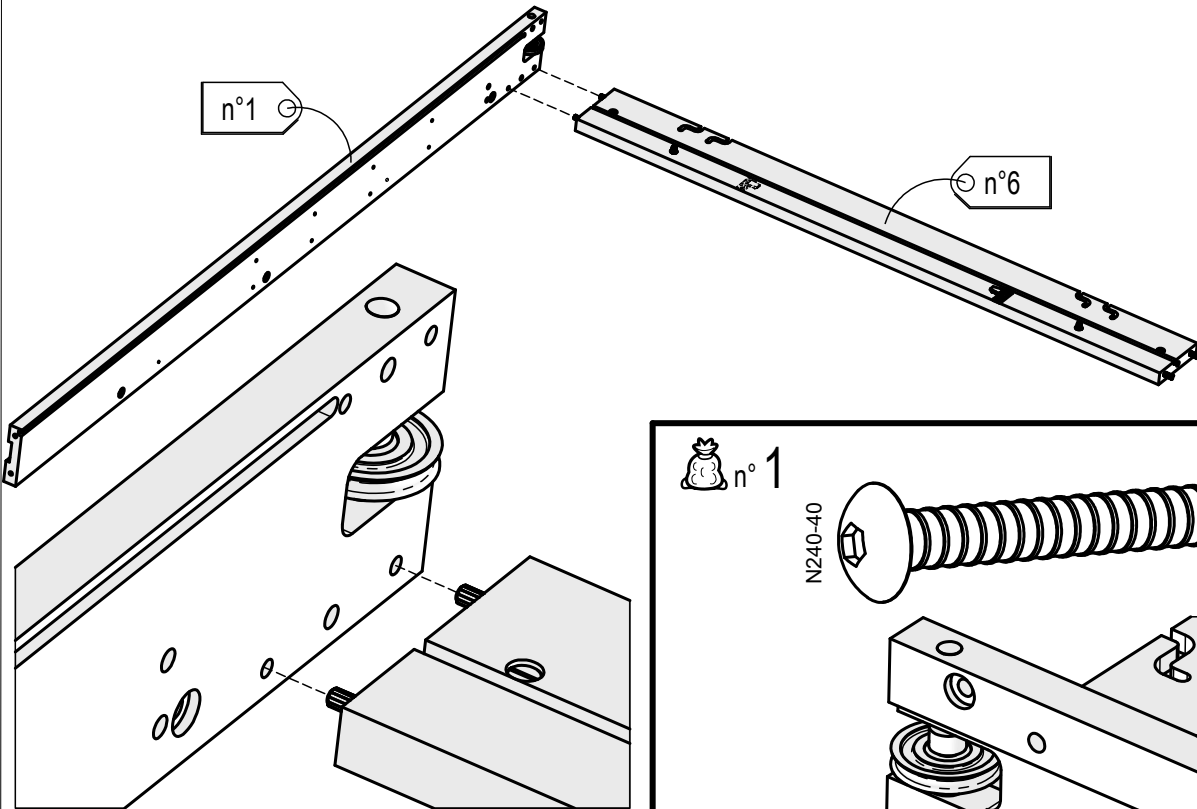
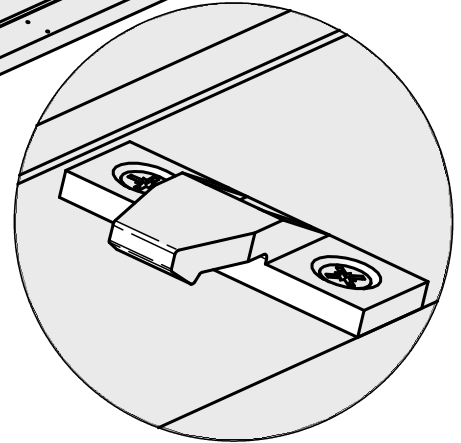
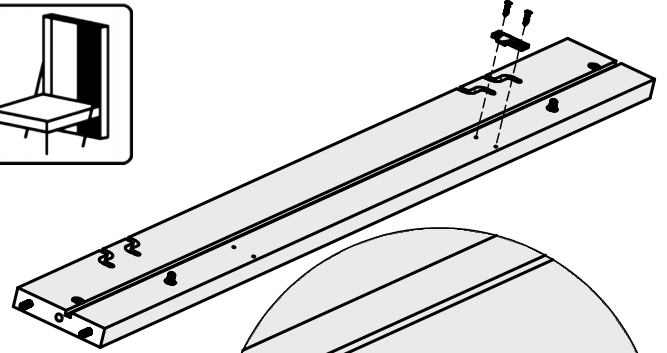
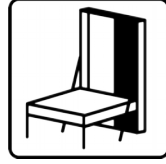
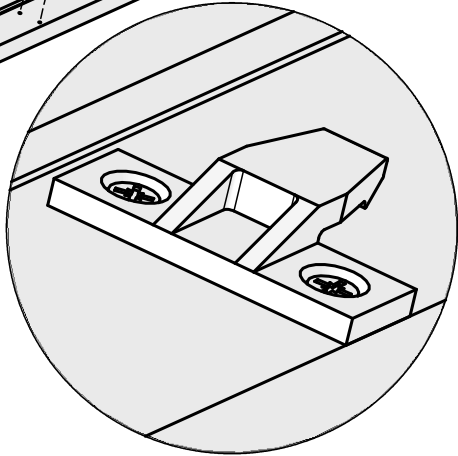
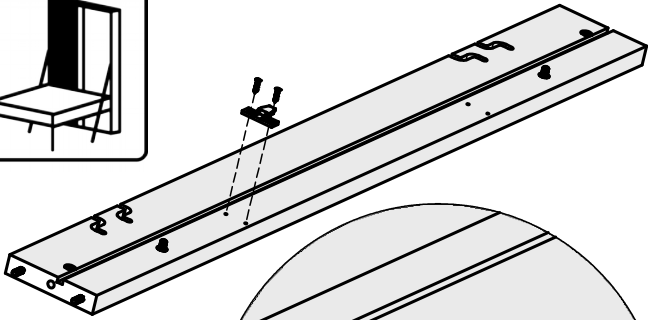
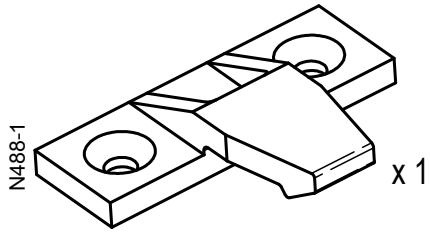

 n°1

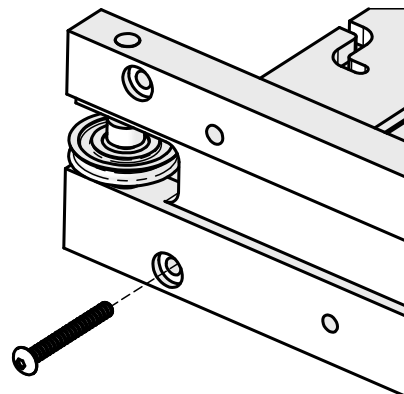
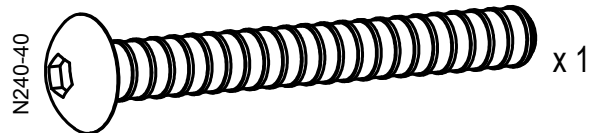

 n°3



 n°7

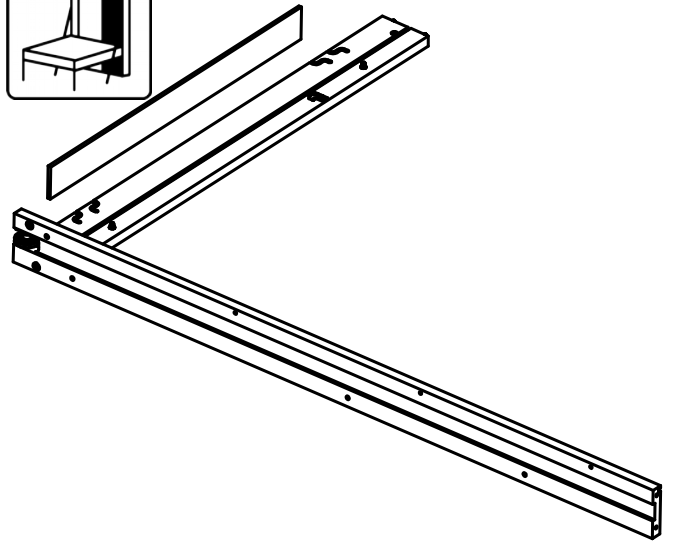
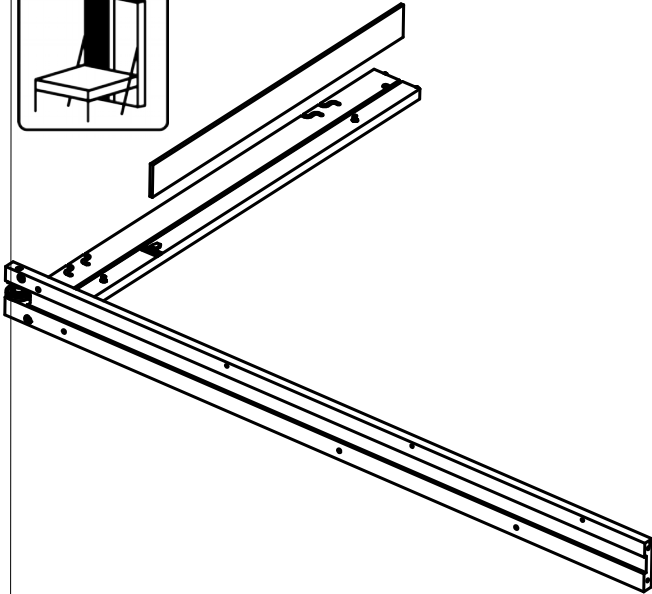
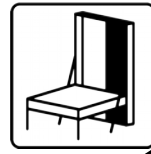

 n°1

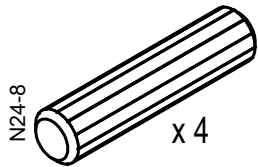
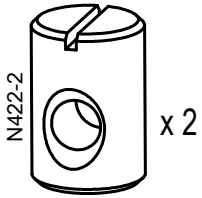

 n°3



 n°8

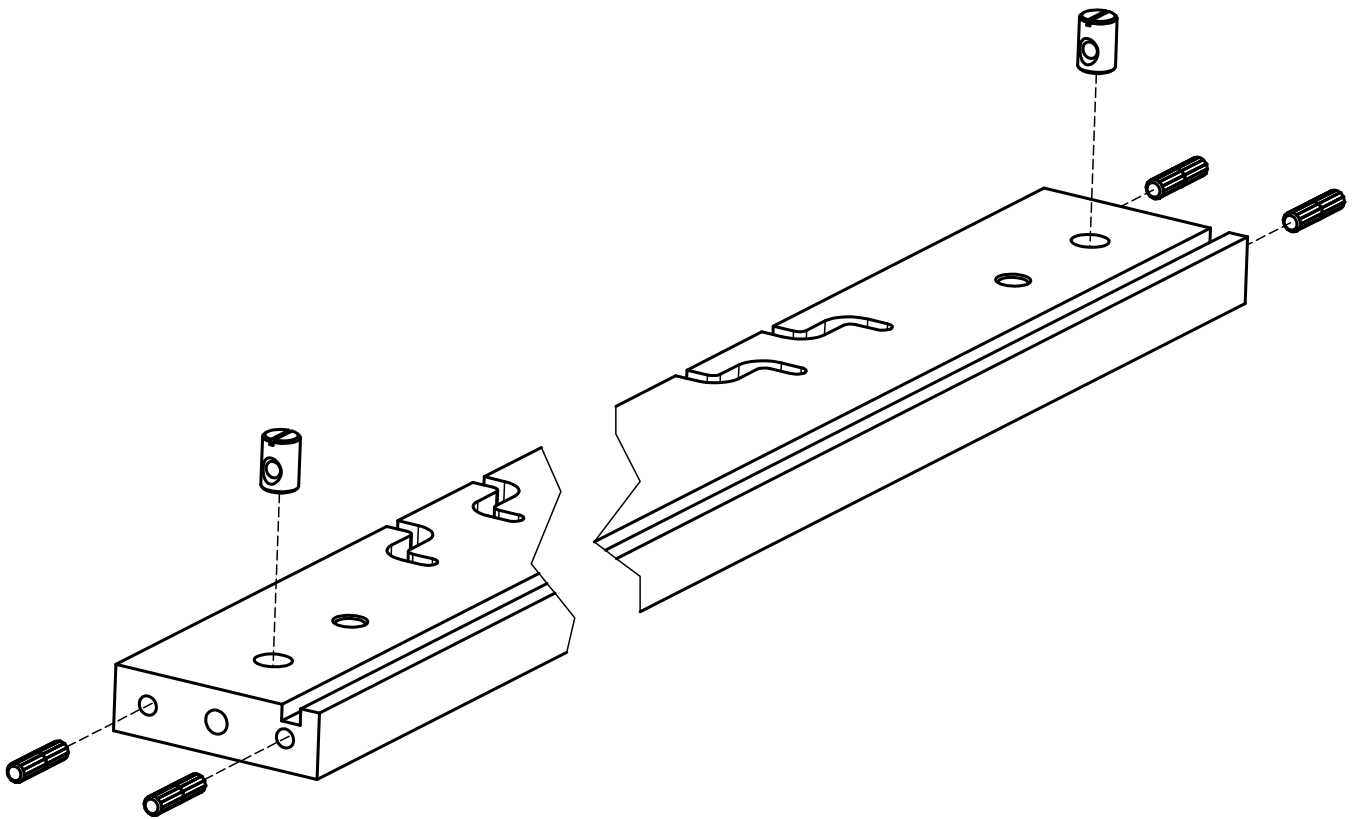

 n°1

N240-31 x 1

N88-118 x 1

 n°2

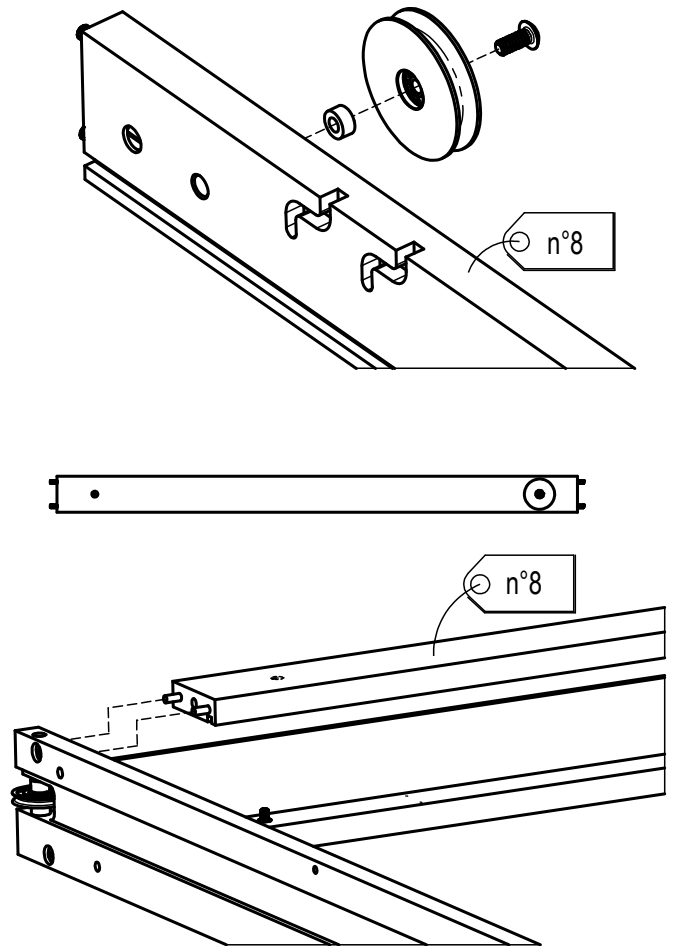
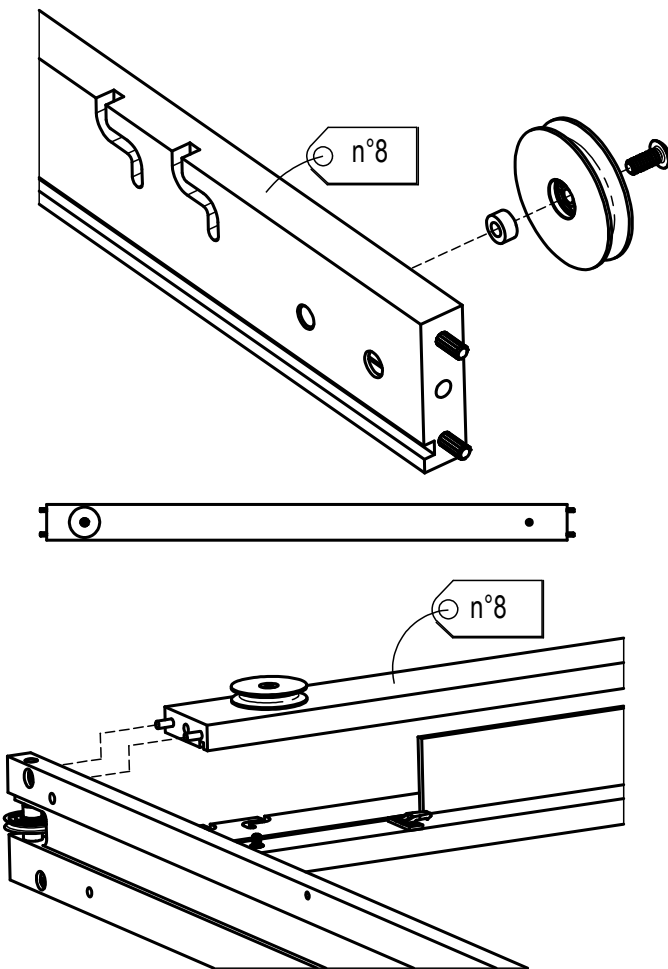
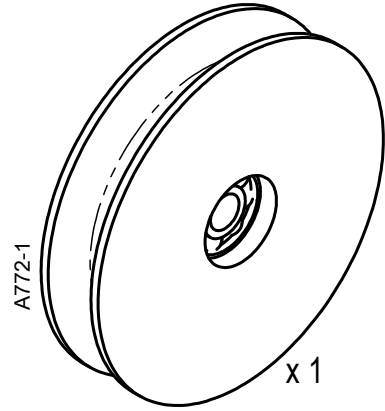

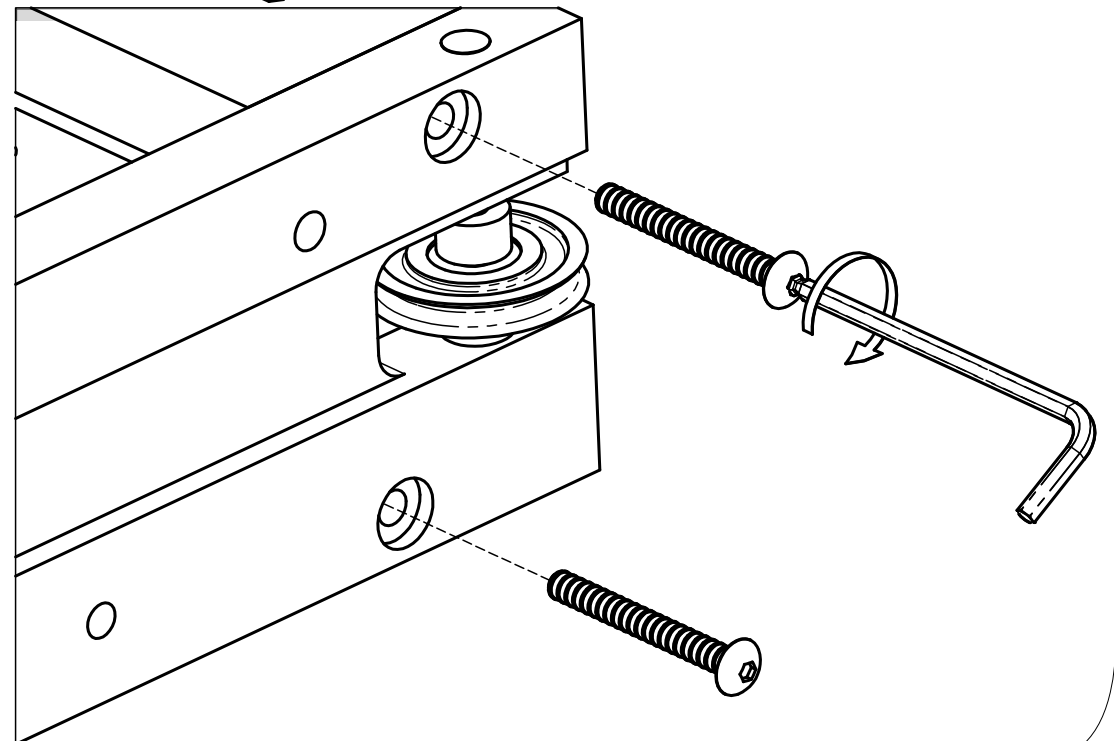
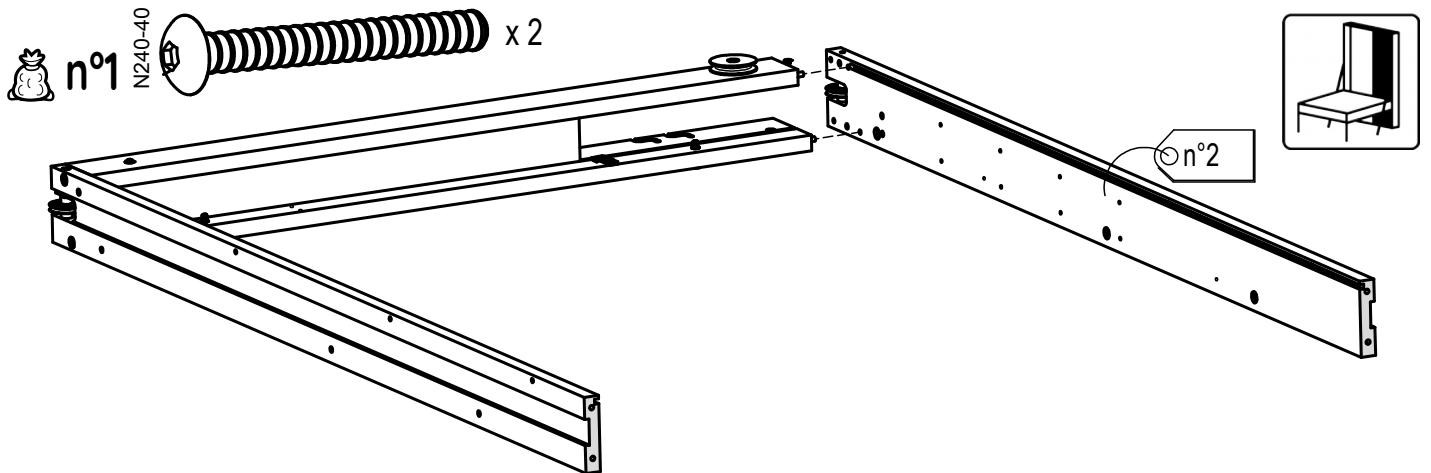
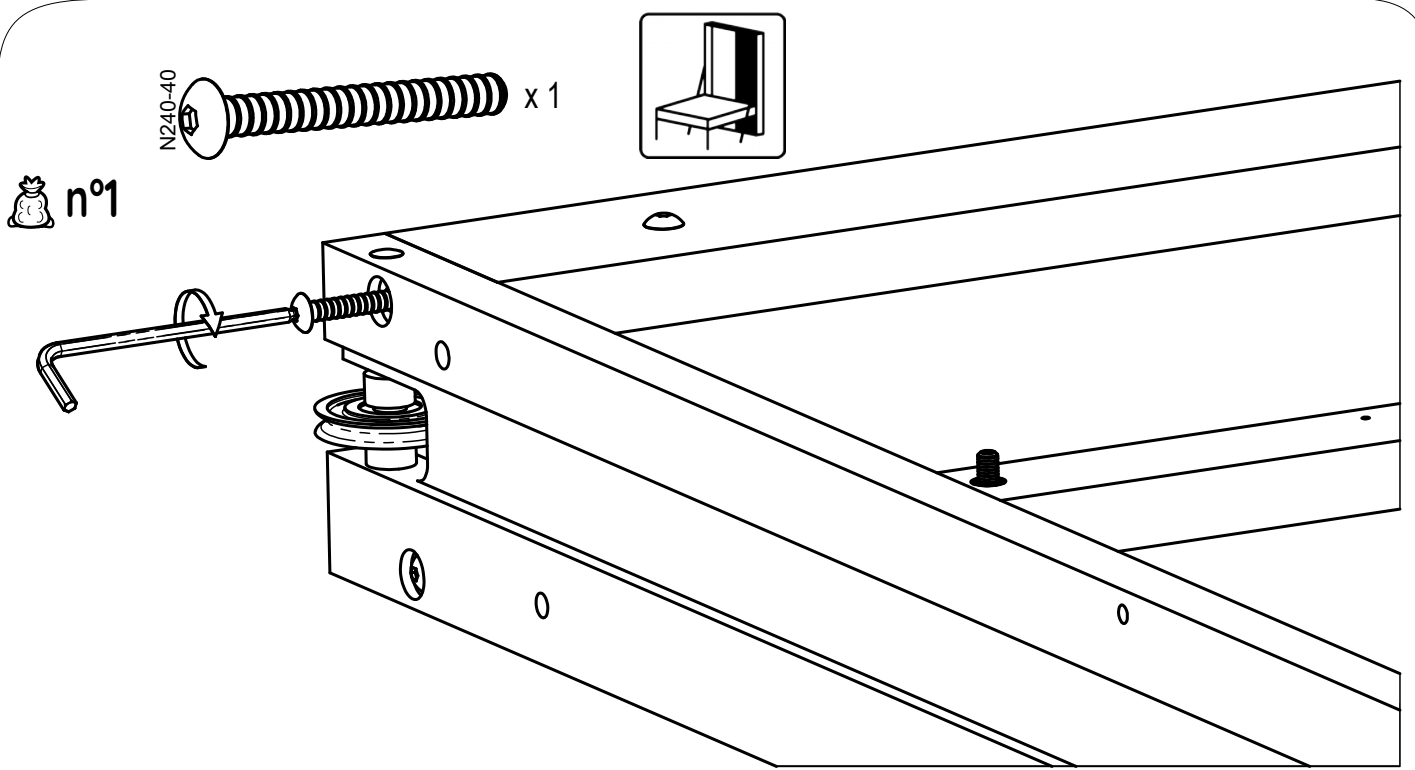

V



n°1

N240-40



x 1

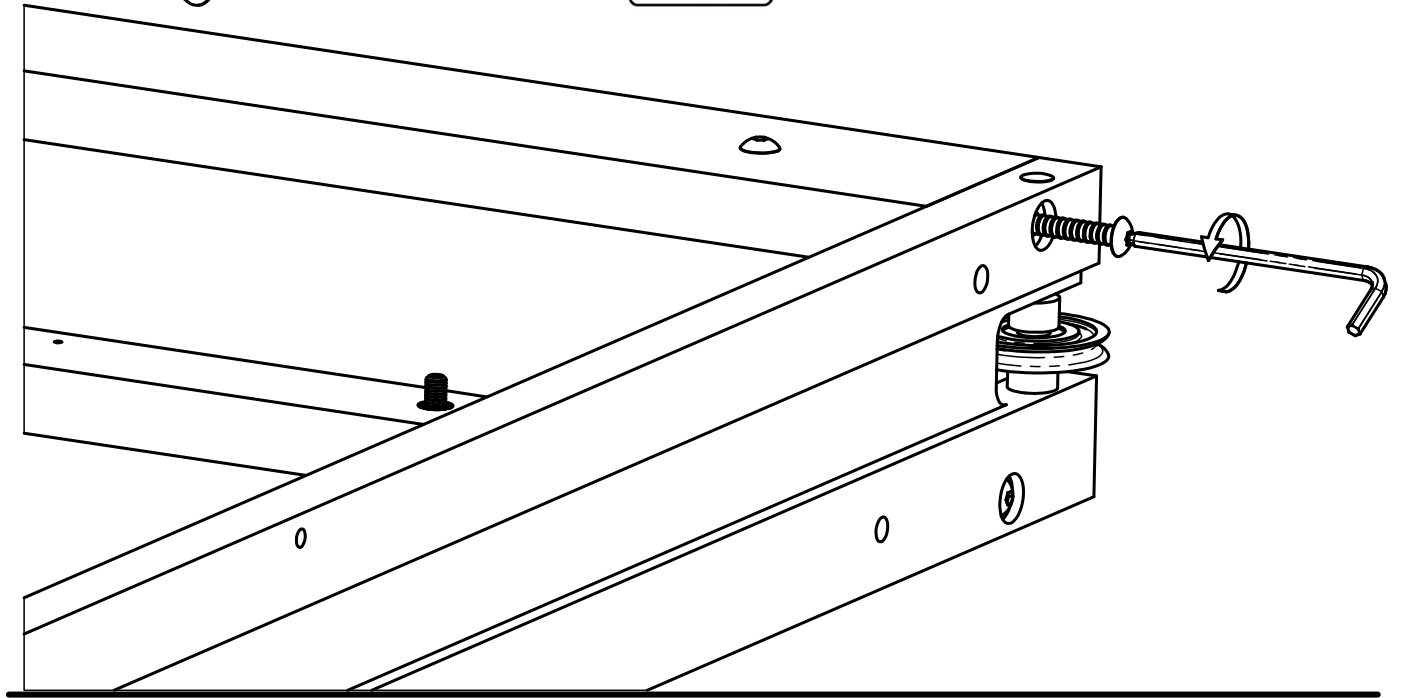

S



n°1

N240-40

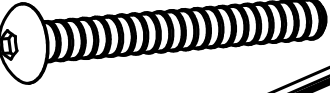

x 2

n°1

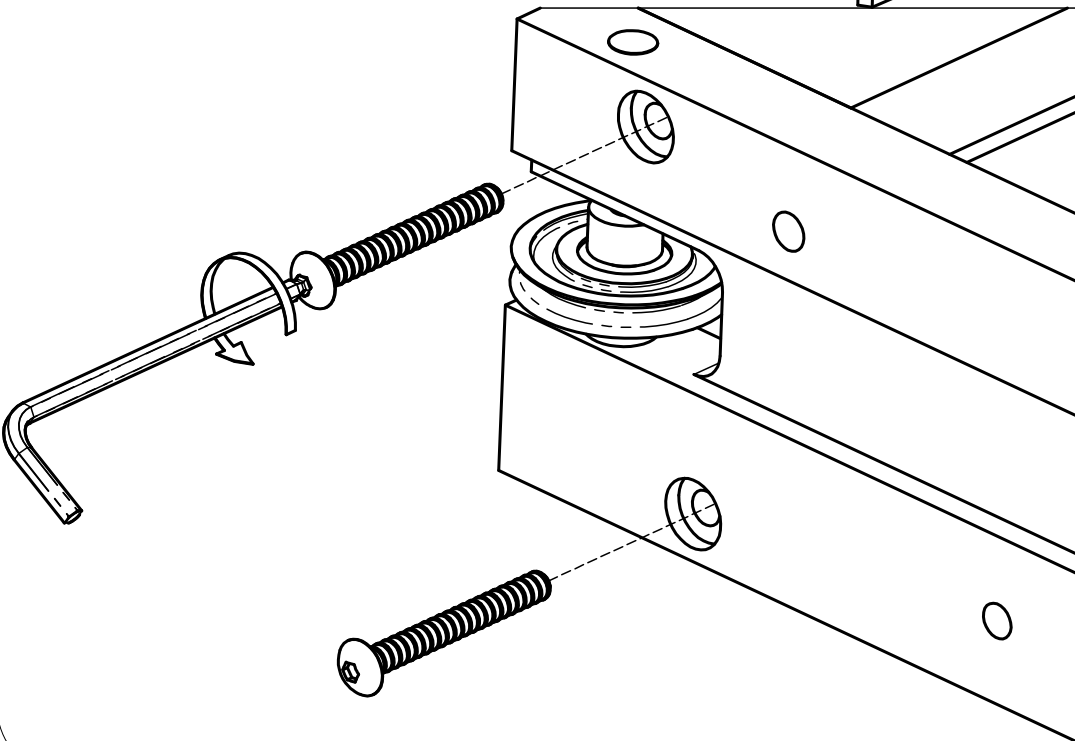
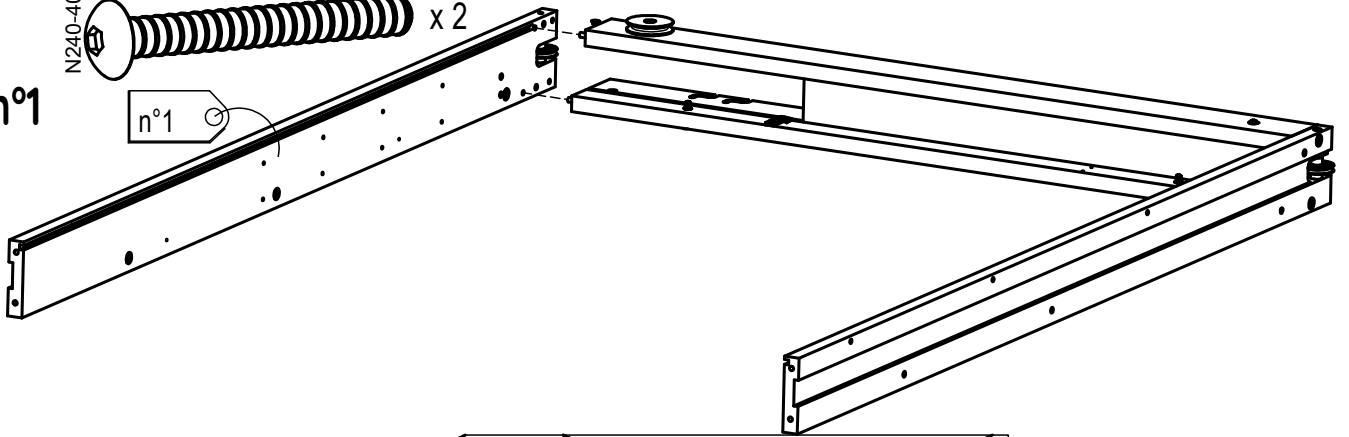

 n°4

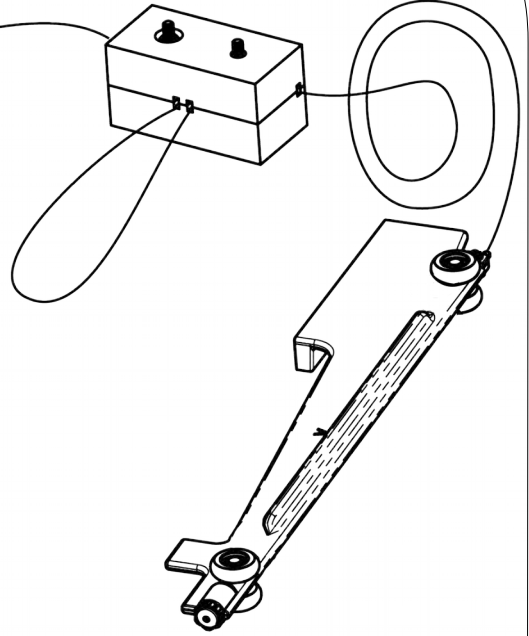
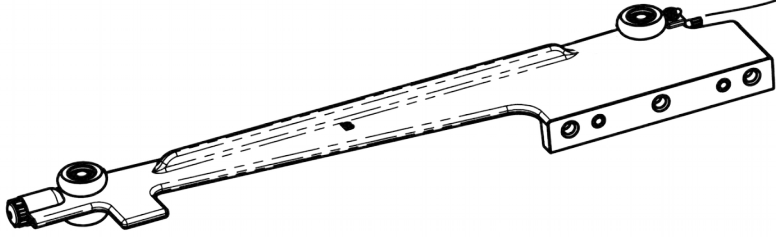

A droite

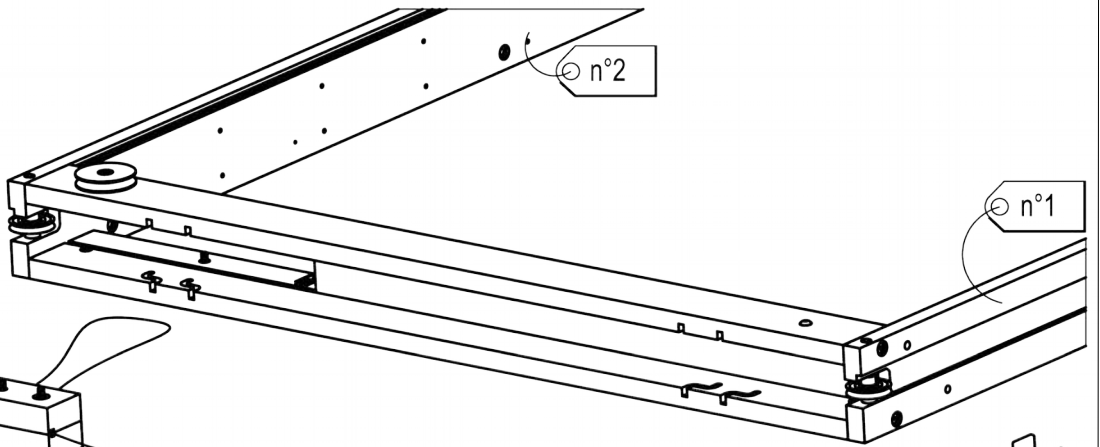
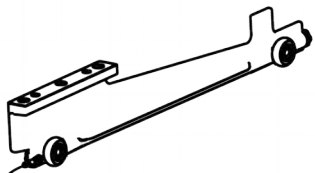

n°1



A droite

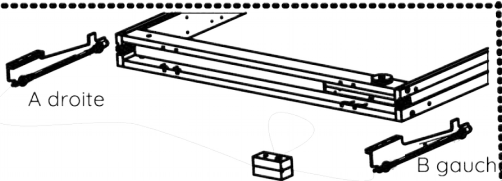

B gauche

B gauche

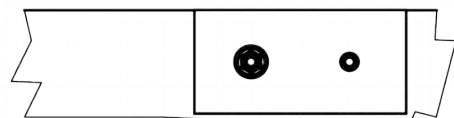
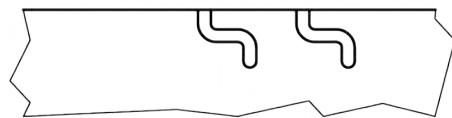
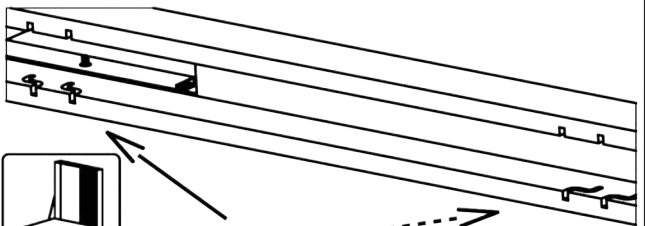

 n°1

N31-21 x2

N330-1 x2

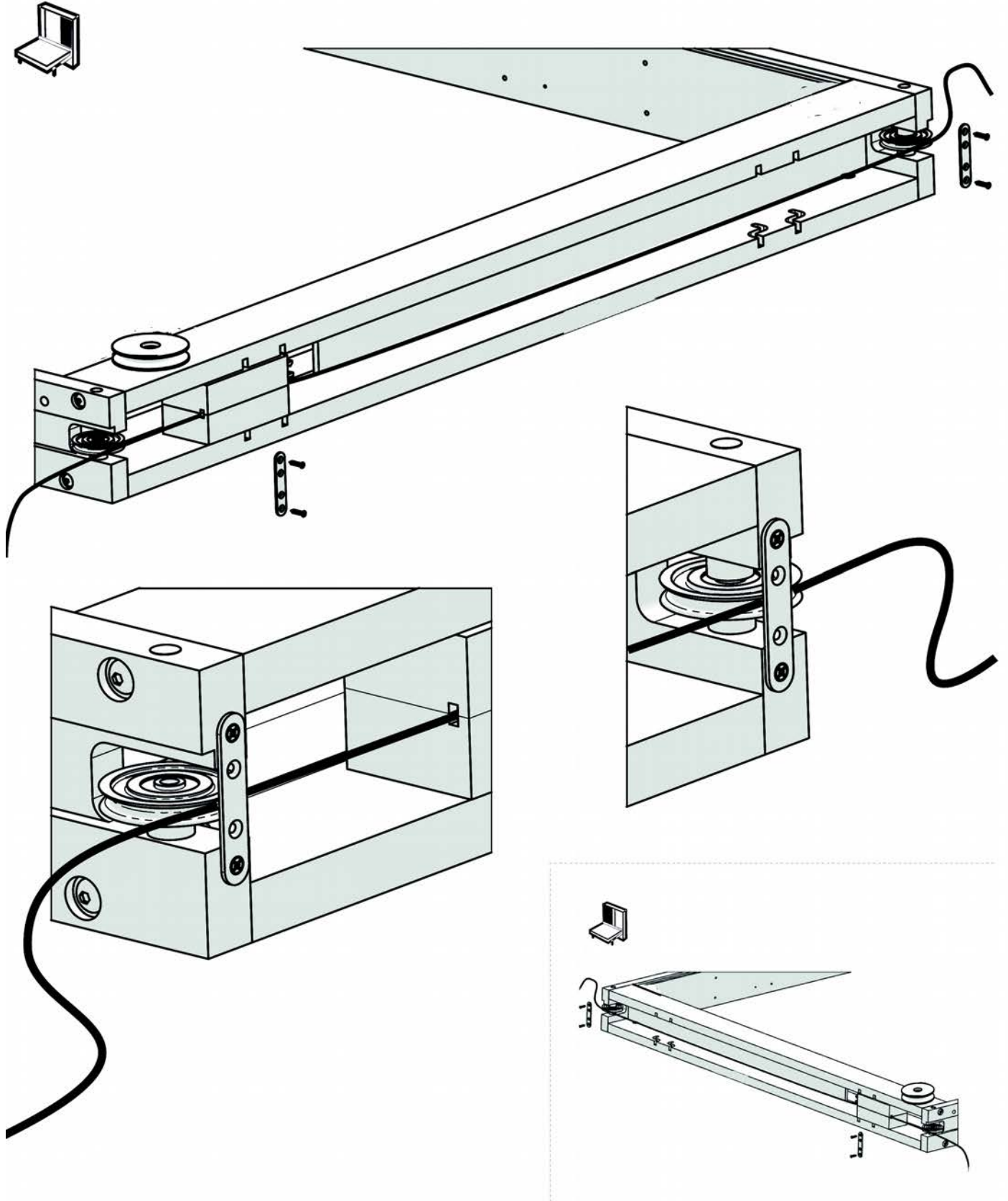

👛 n°3

N546-1

x 1

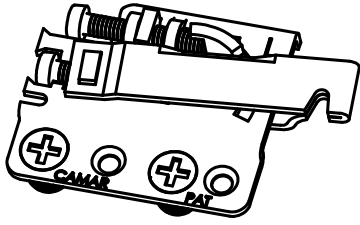

N546-2

x 1

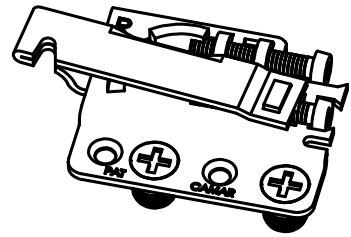

MAX

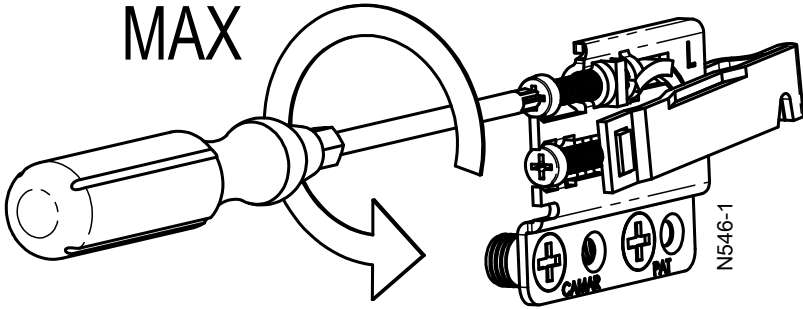

MAX

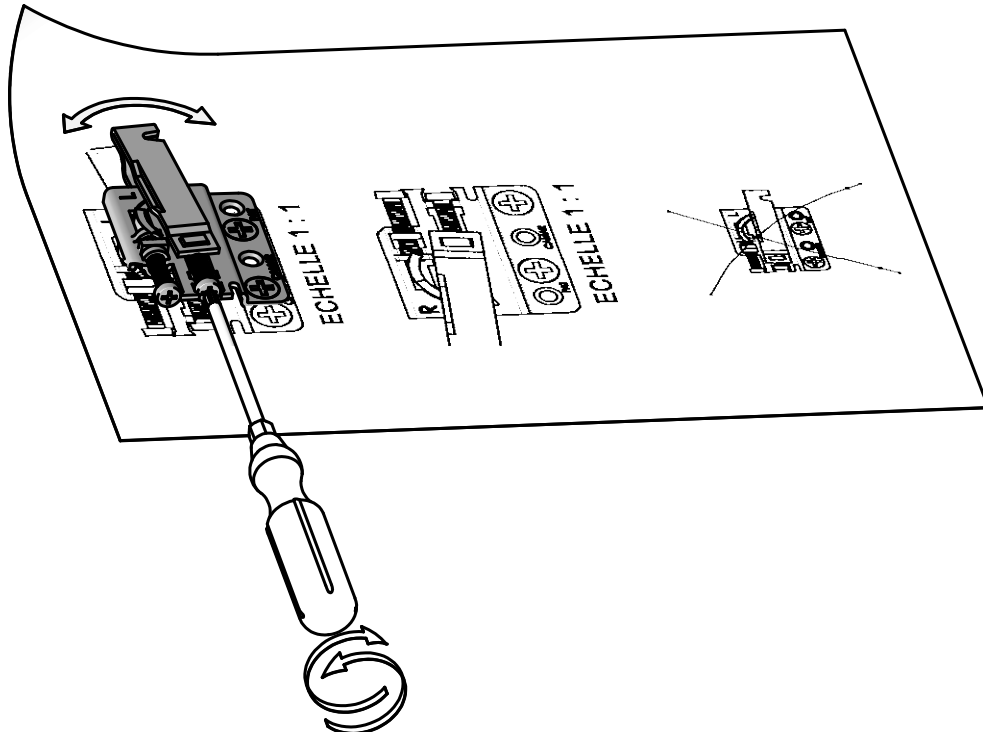
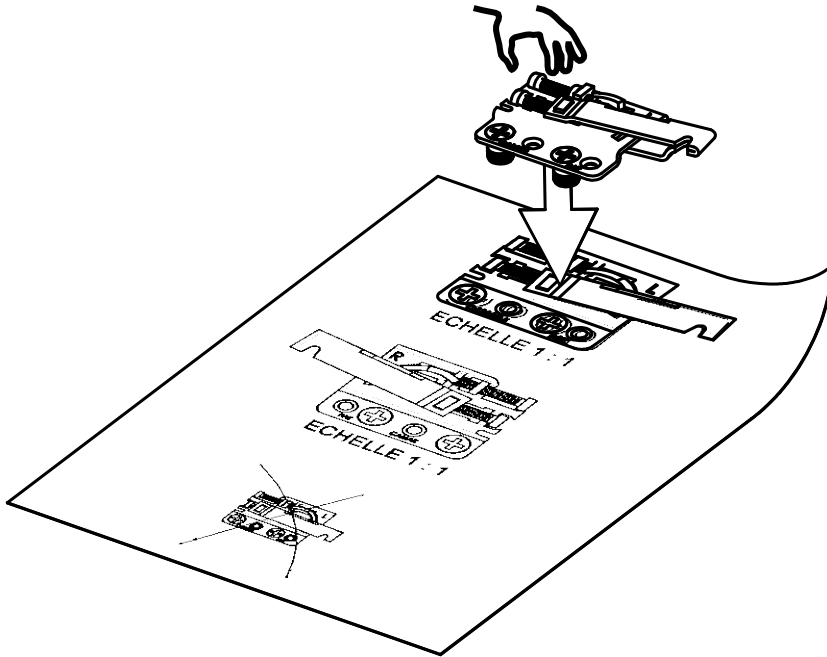
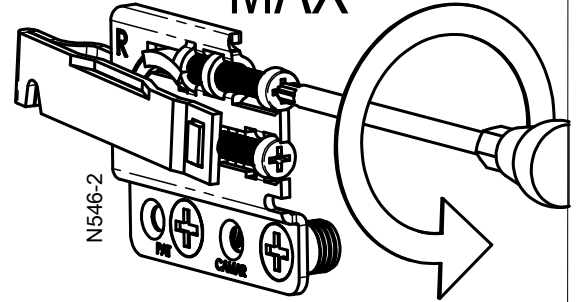

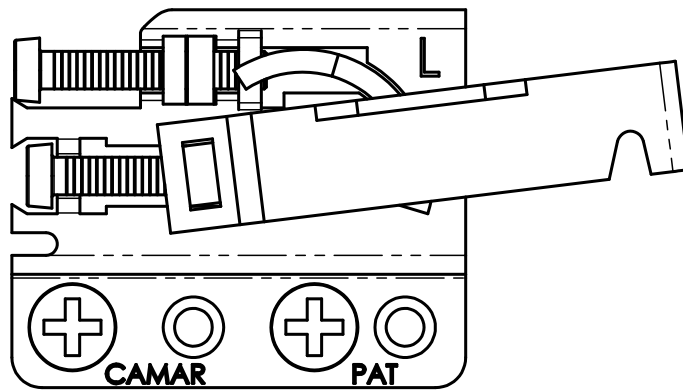

ÉCHELLE 1

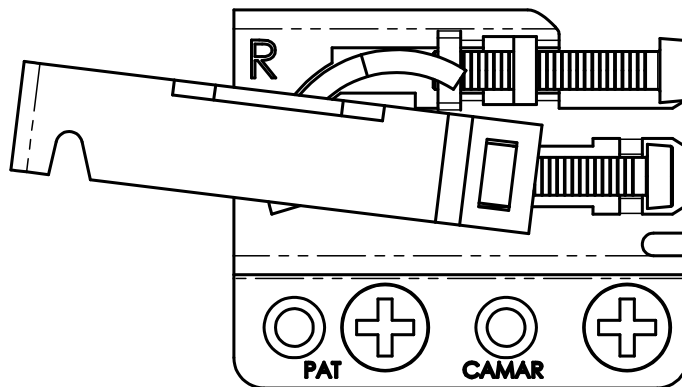

ÉCHELLE 1

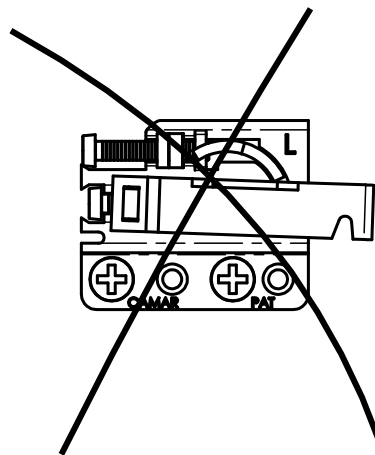

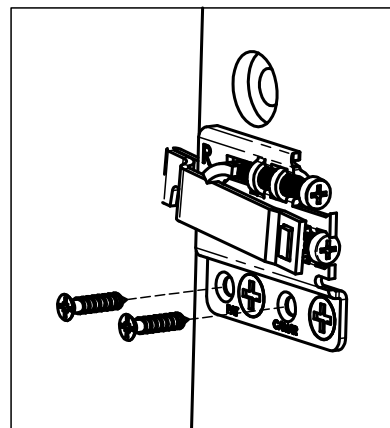
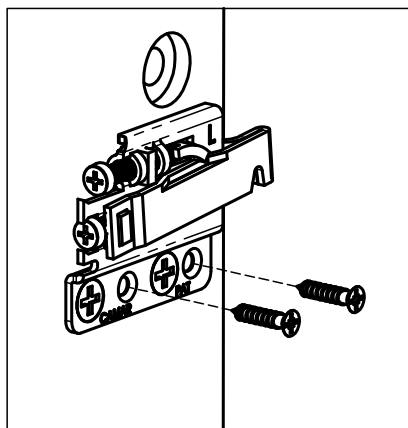
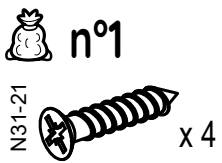
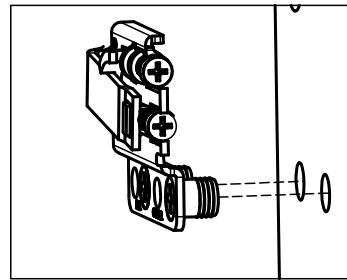
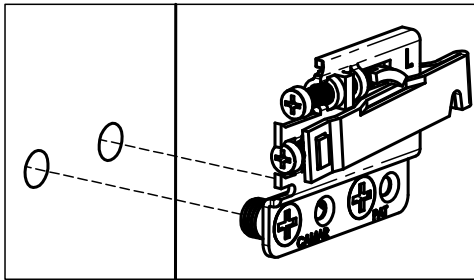
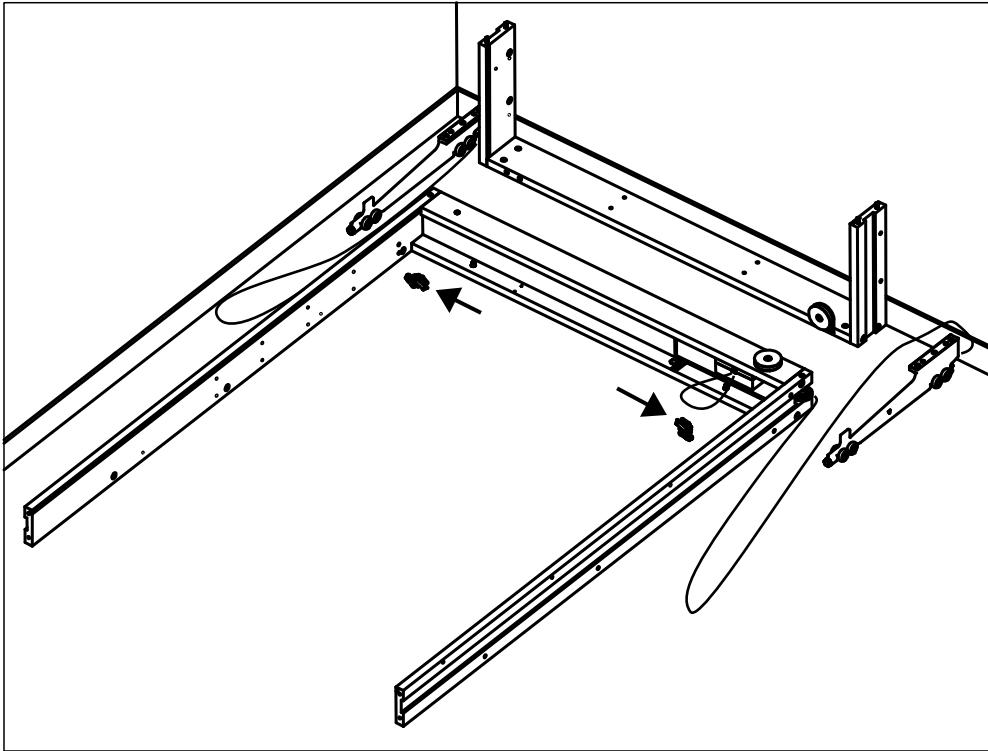
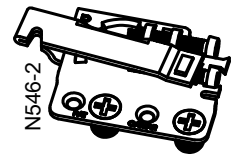
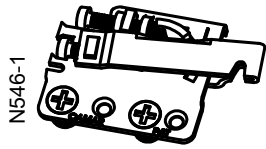

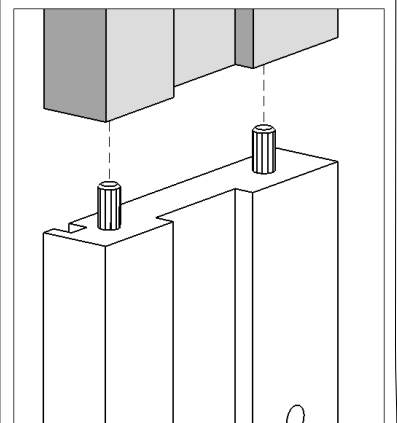
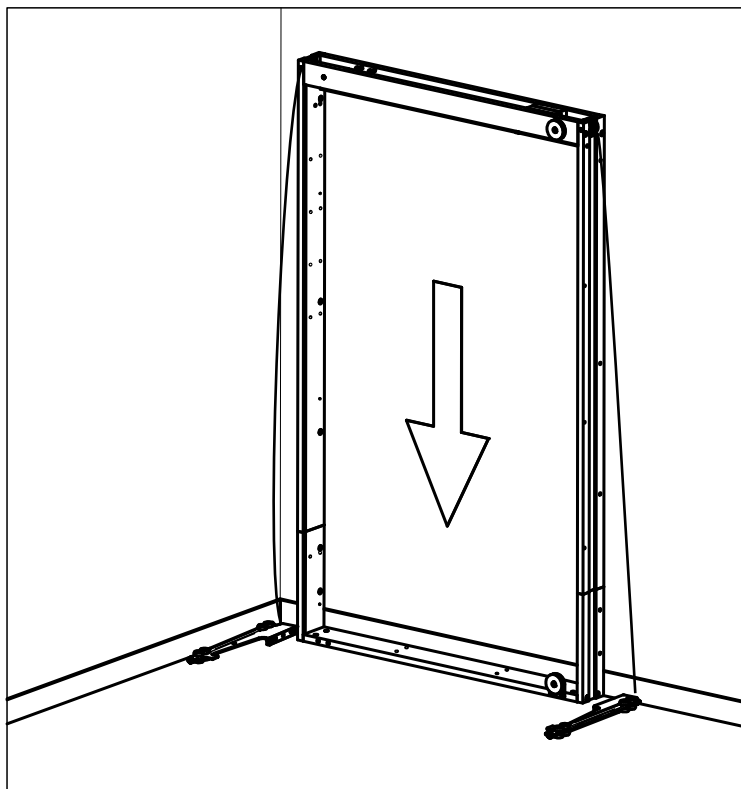
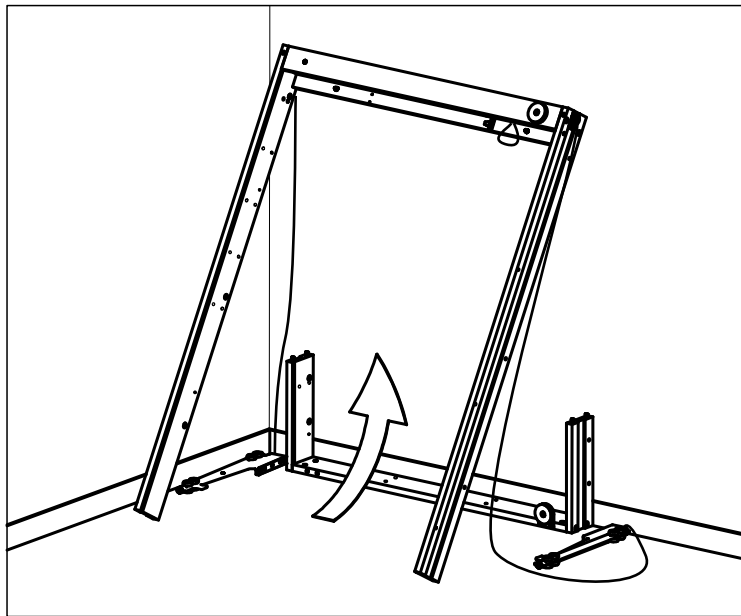
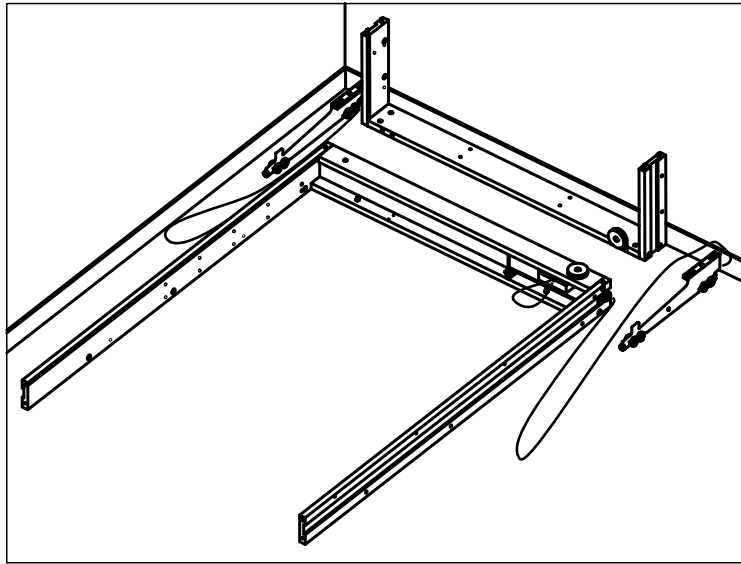

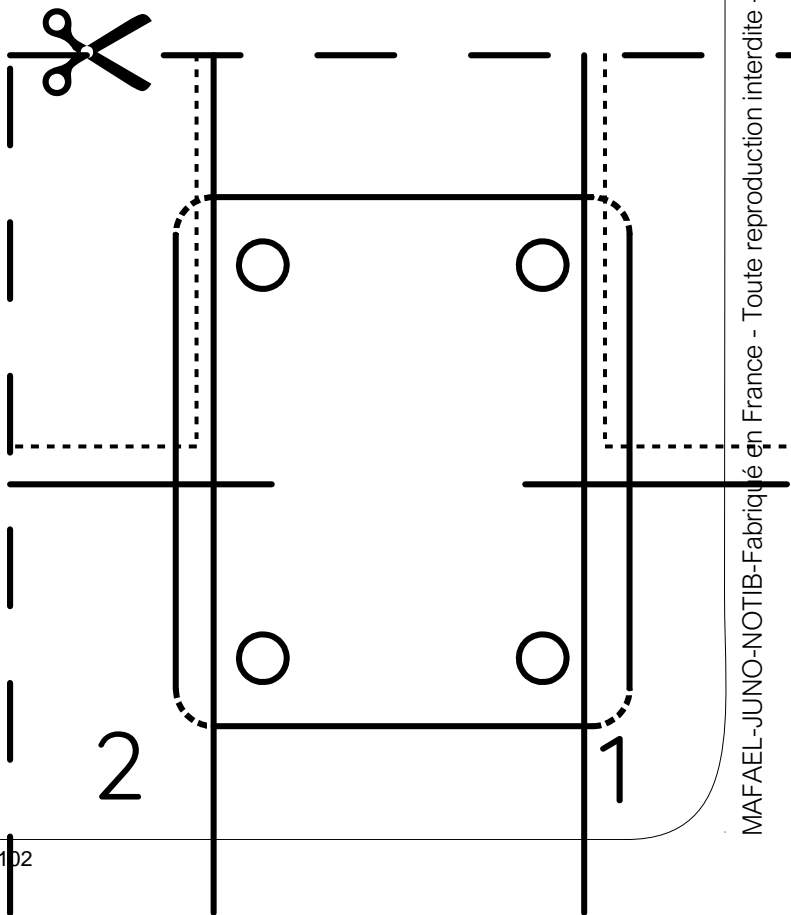
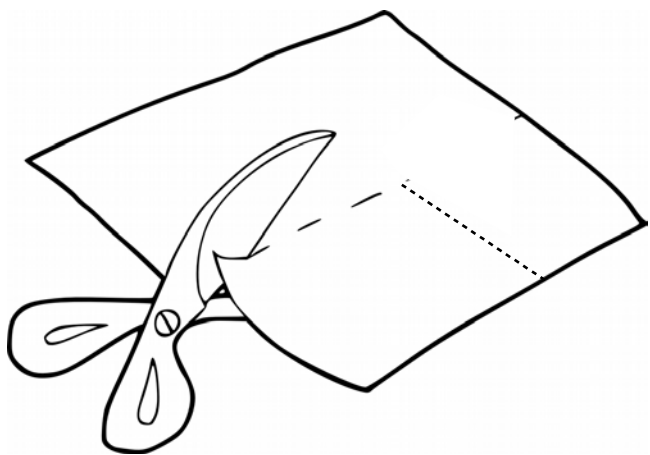
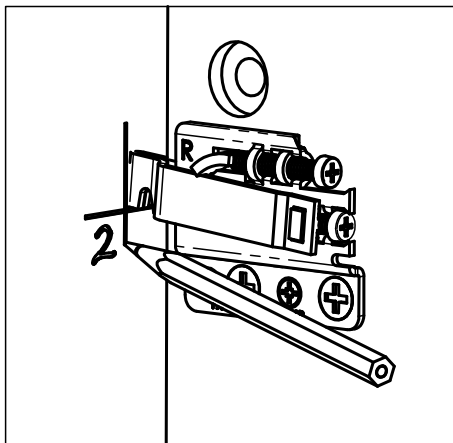
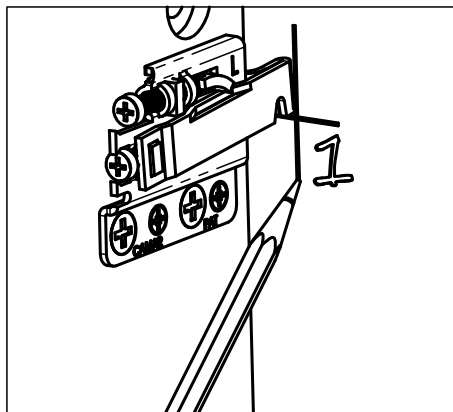
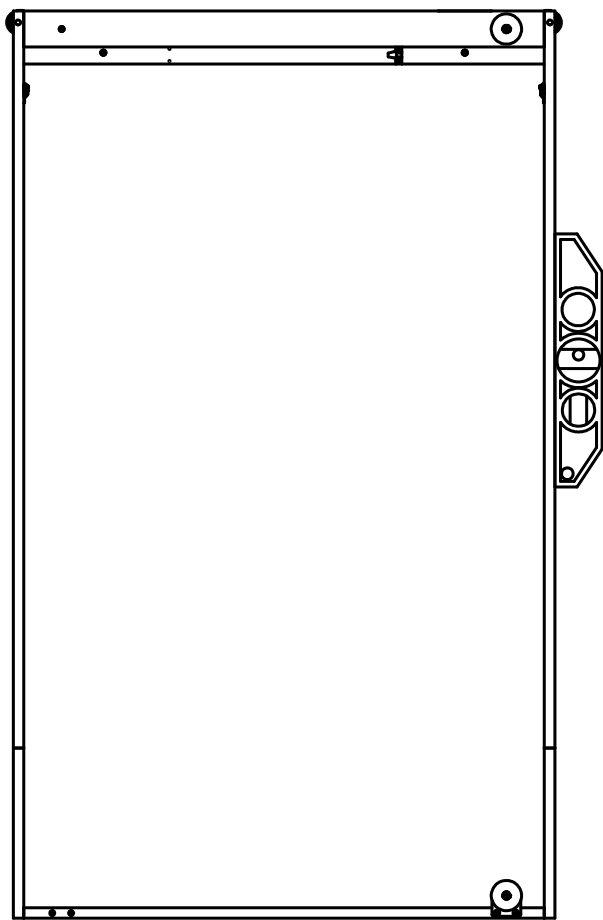

1 = Gauche
2 = Droite

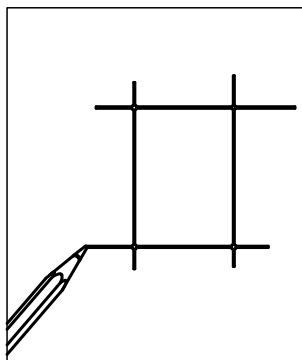
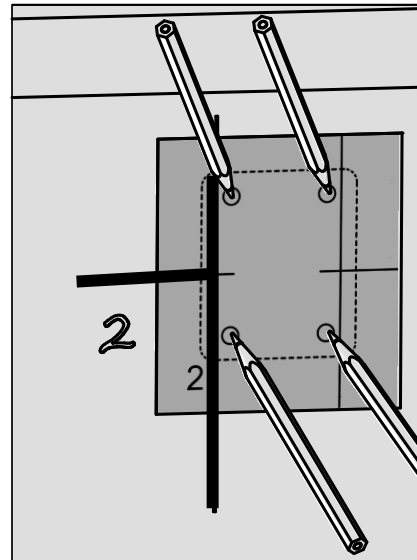
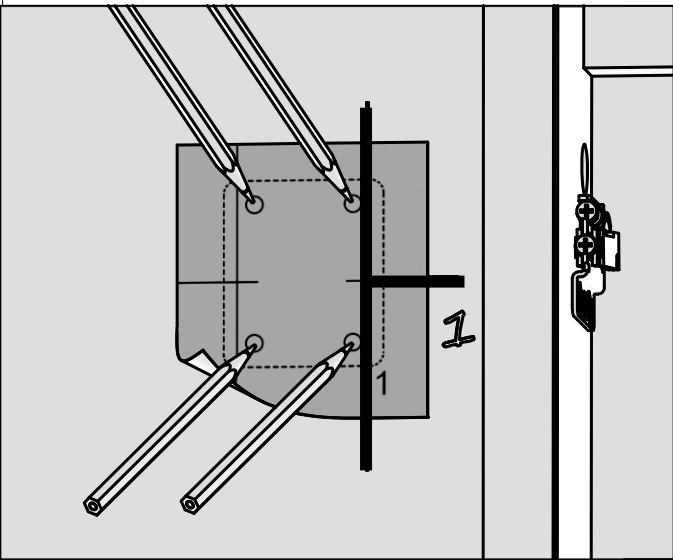
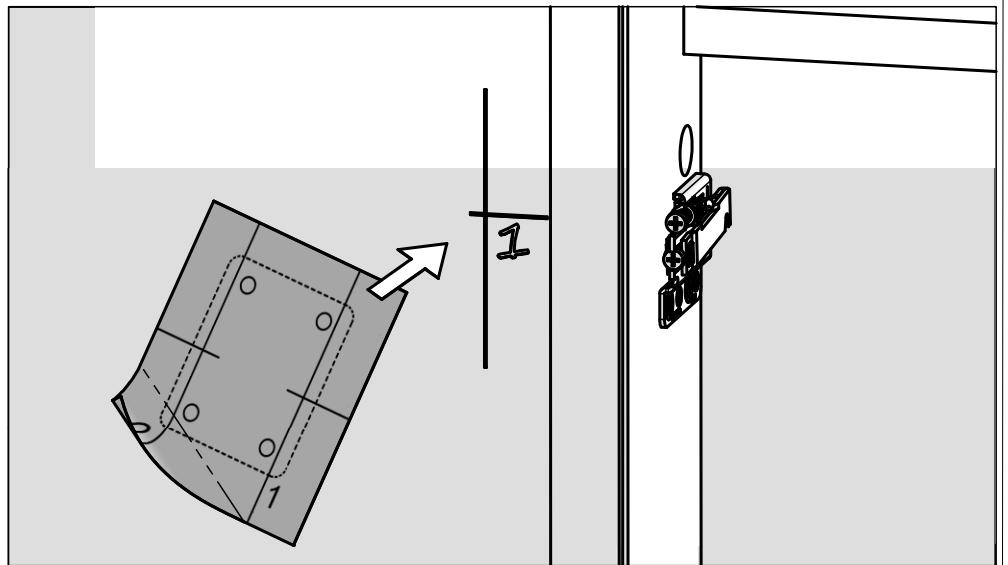
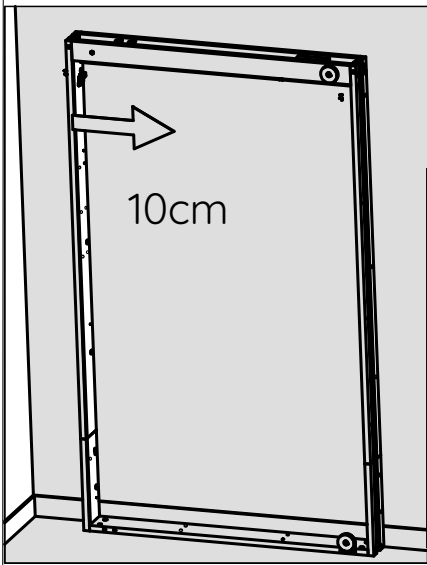

x2

∅ 6

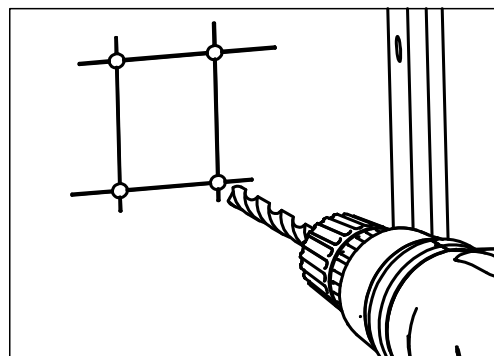

x2

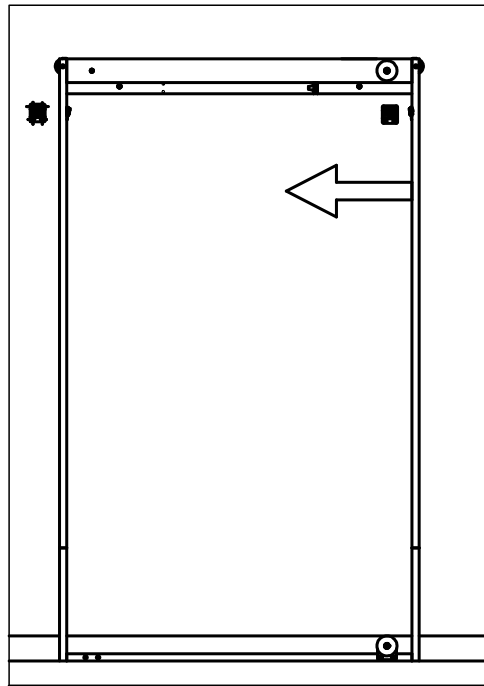
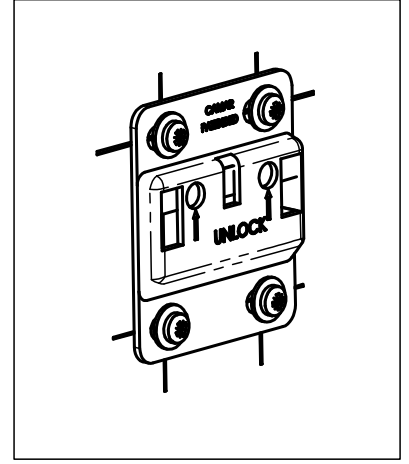
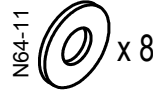
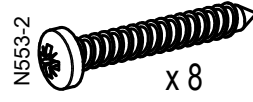
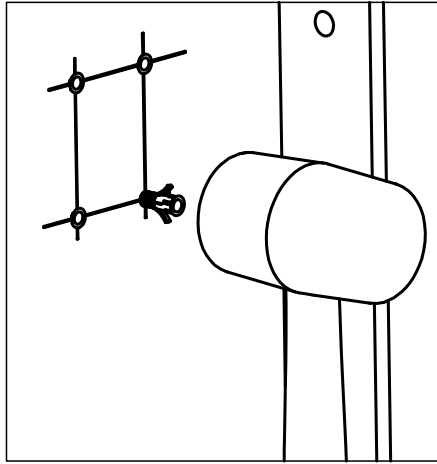
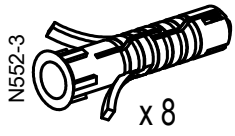

CLIC

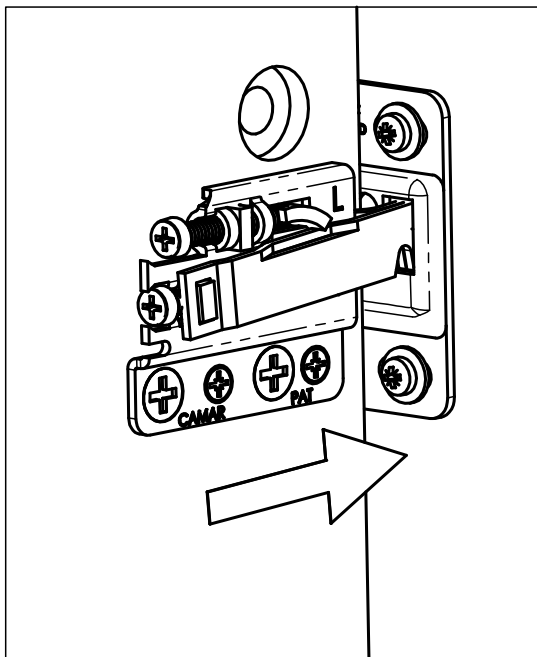

CLIC

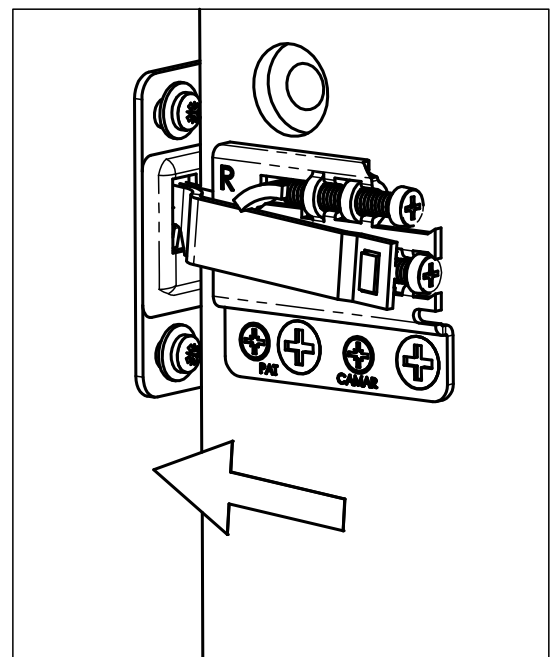

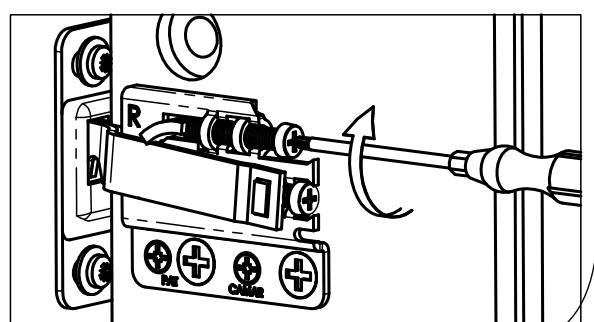
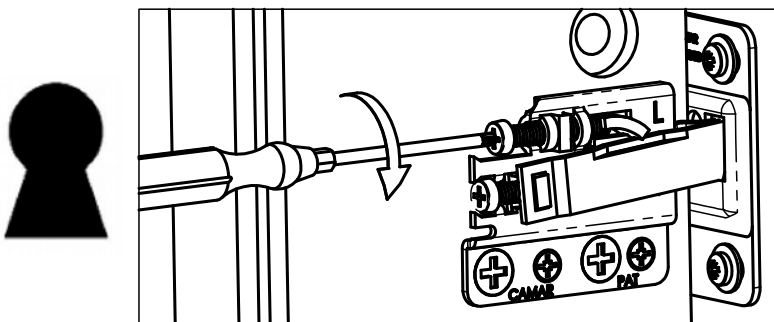
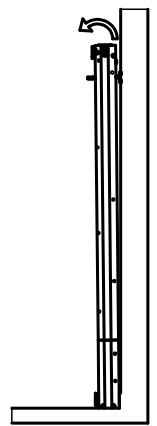
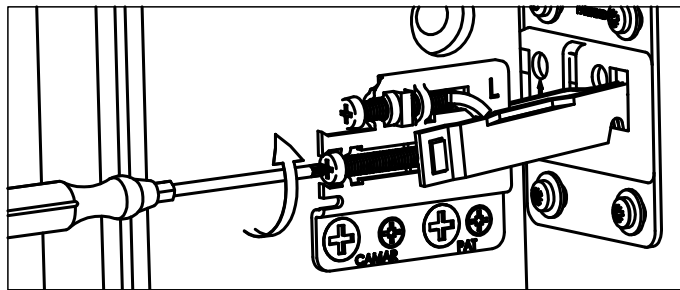
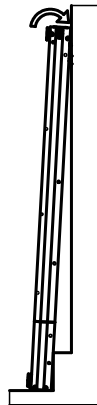
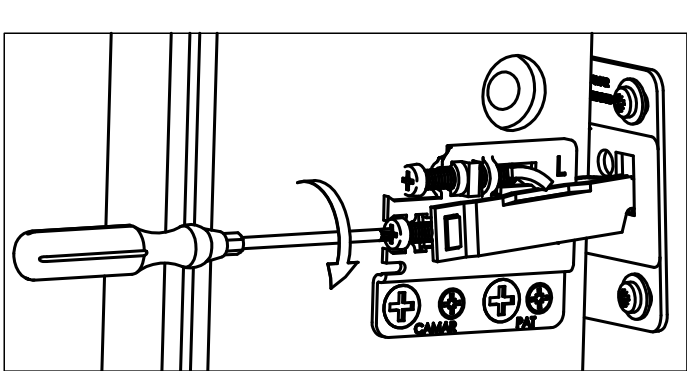
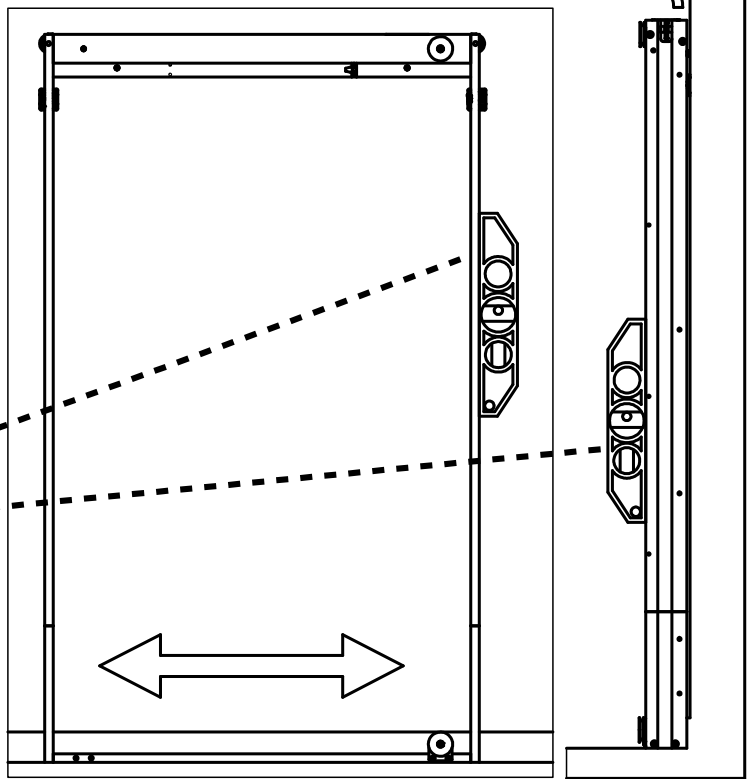
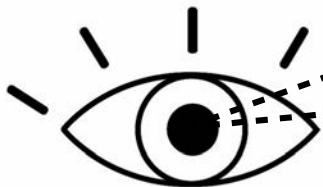

 n°5

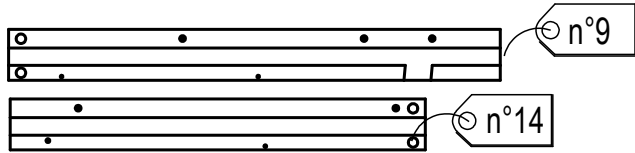

 n°1

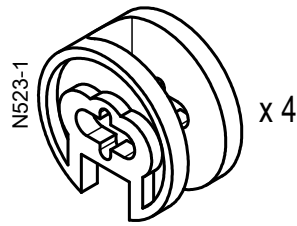
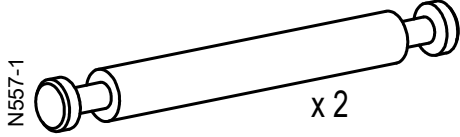

S832-2

 n°1

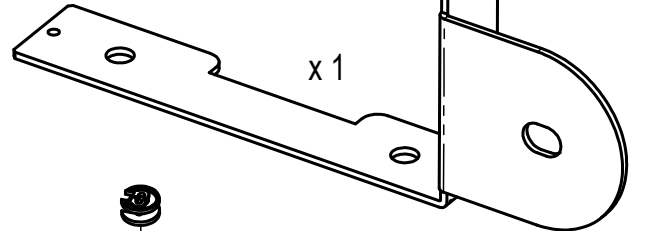

x1

1

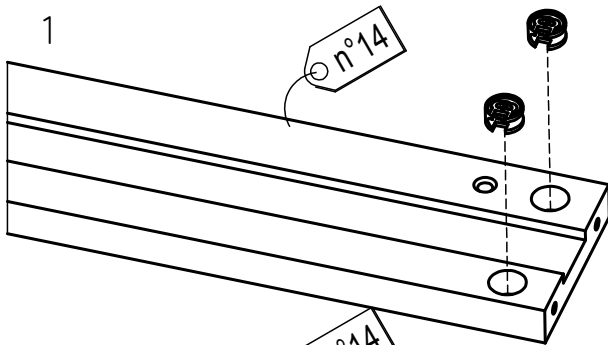

n°14

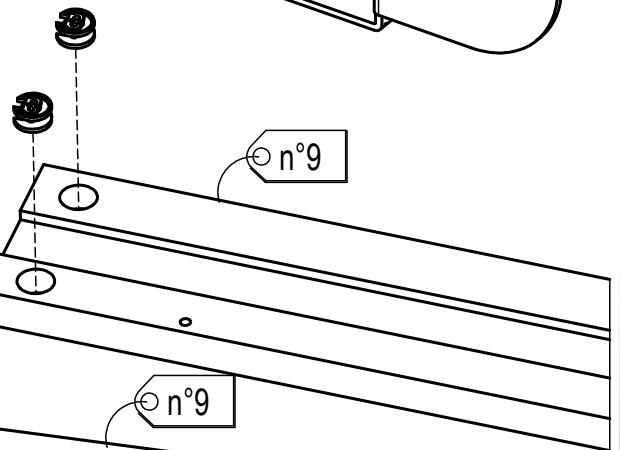

n°9

2

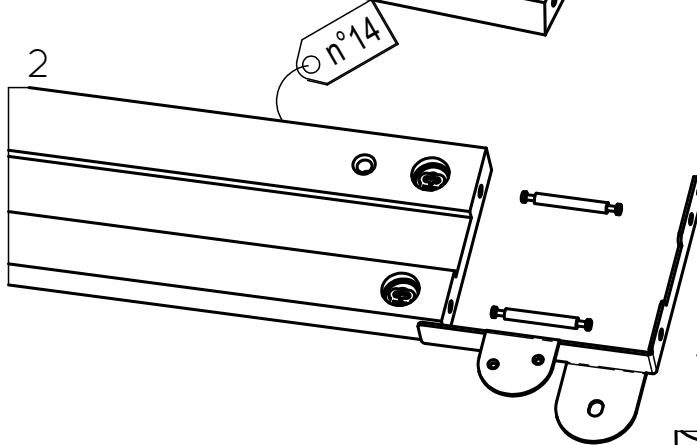

n°14

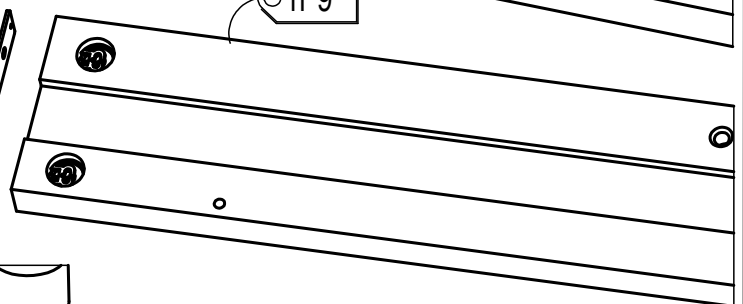

n°9

3

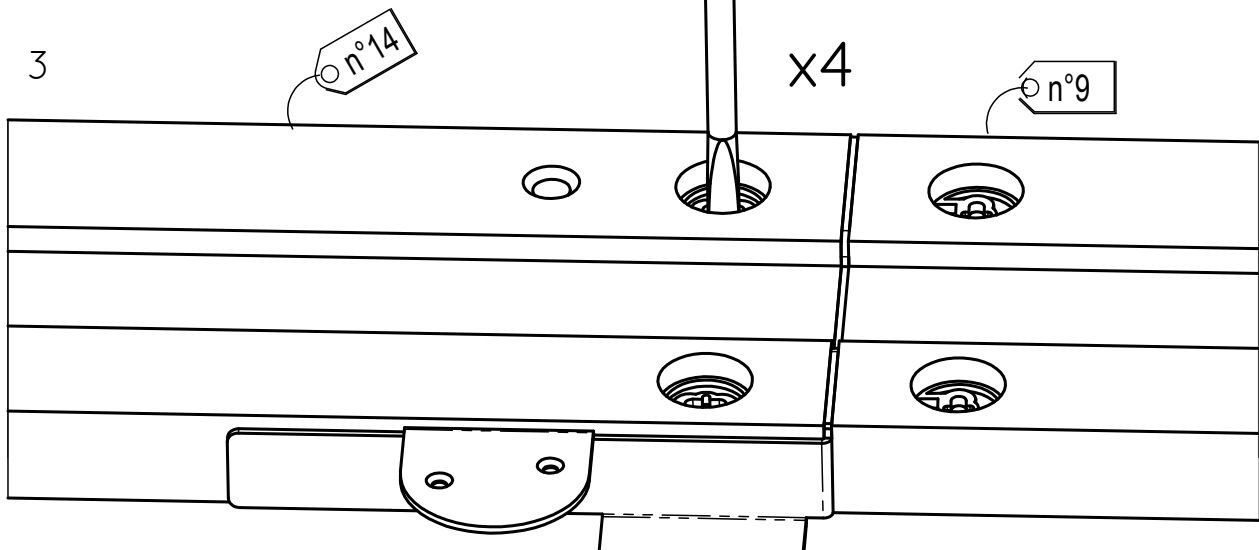

n°14

x4

n°9

n°5

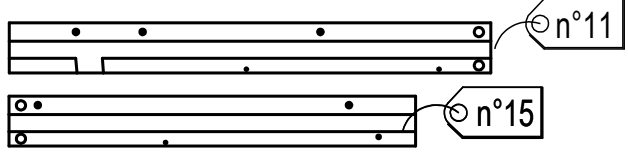

n°1

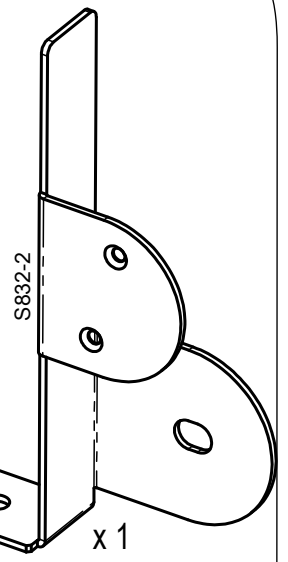
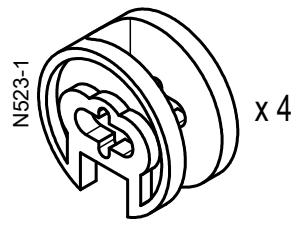
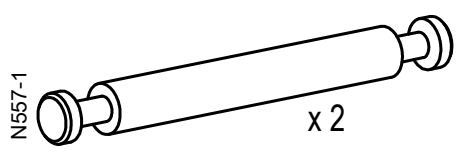

n°1

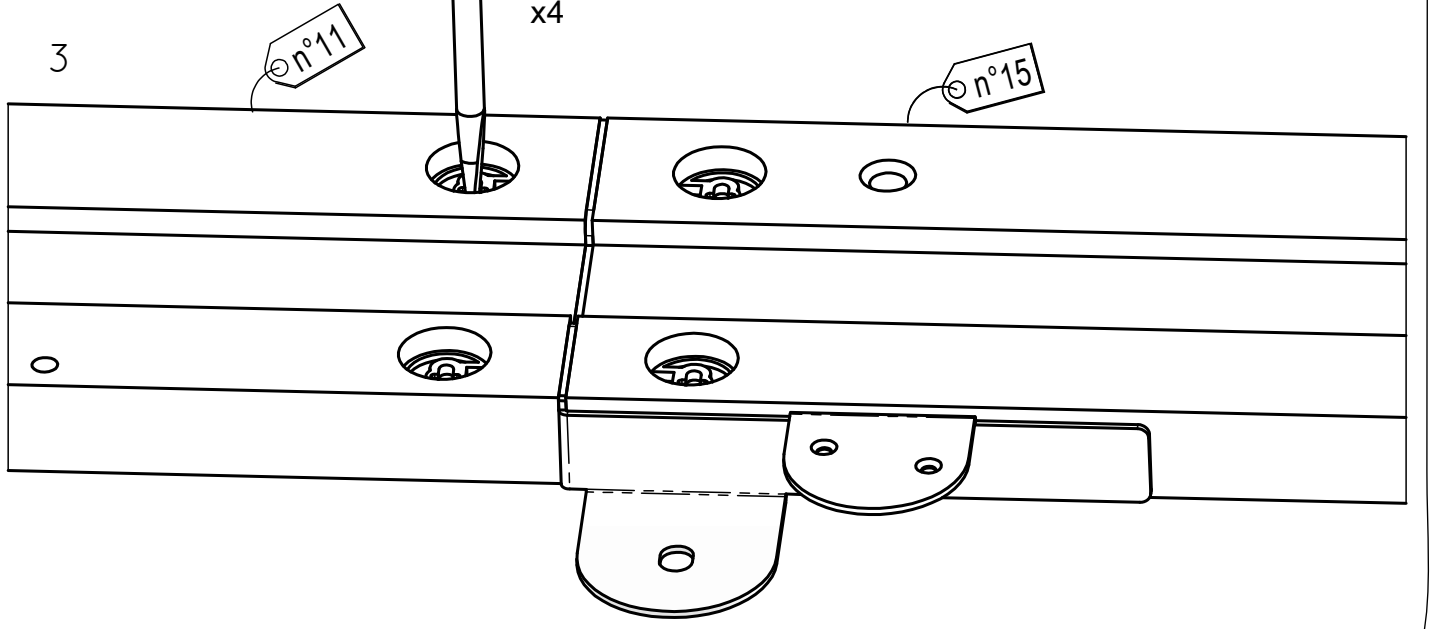
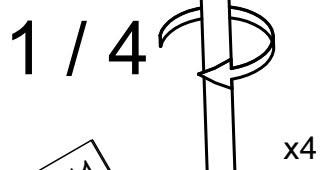
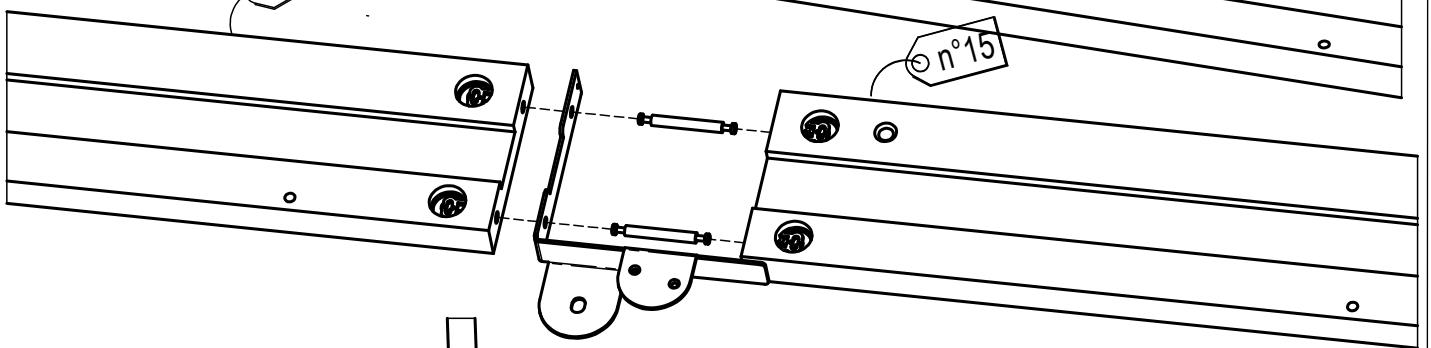
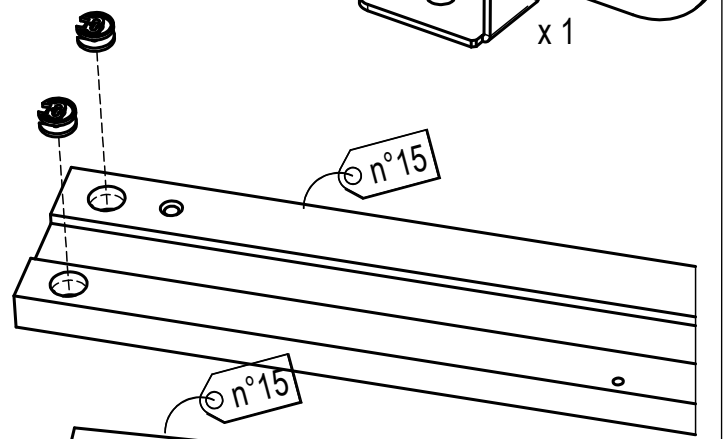
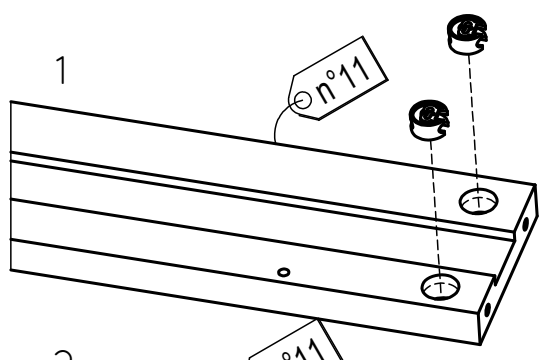
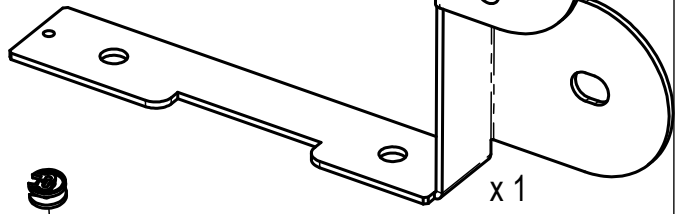

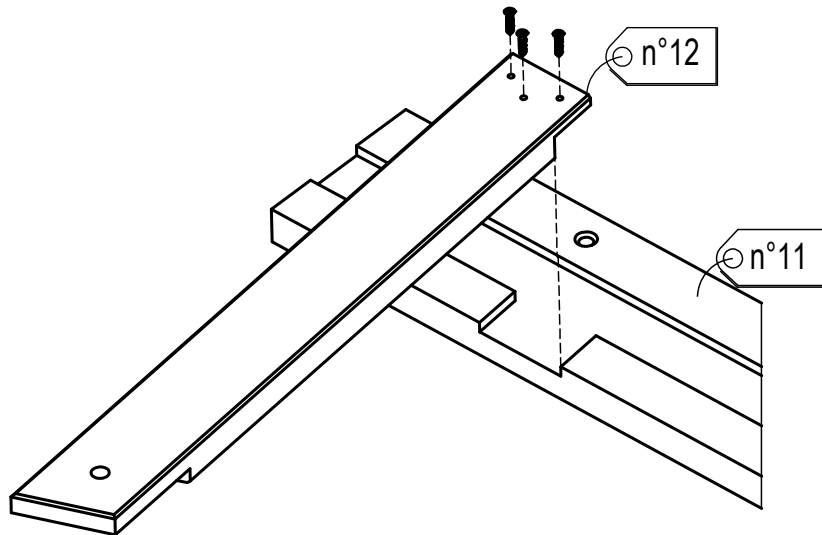
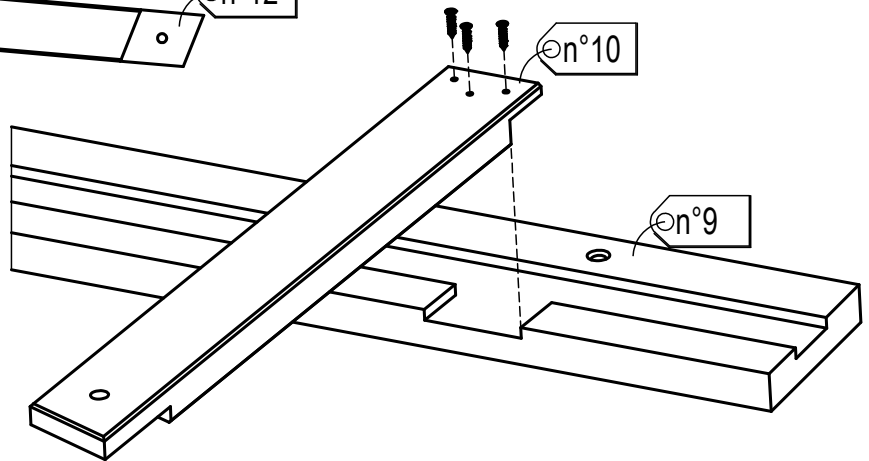
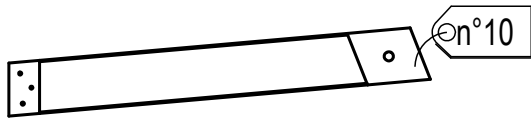
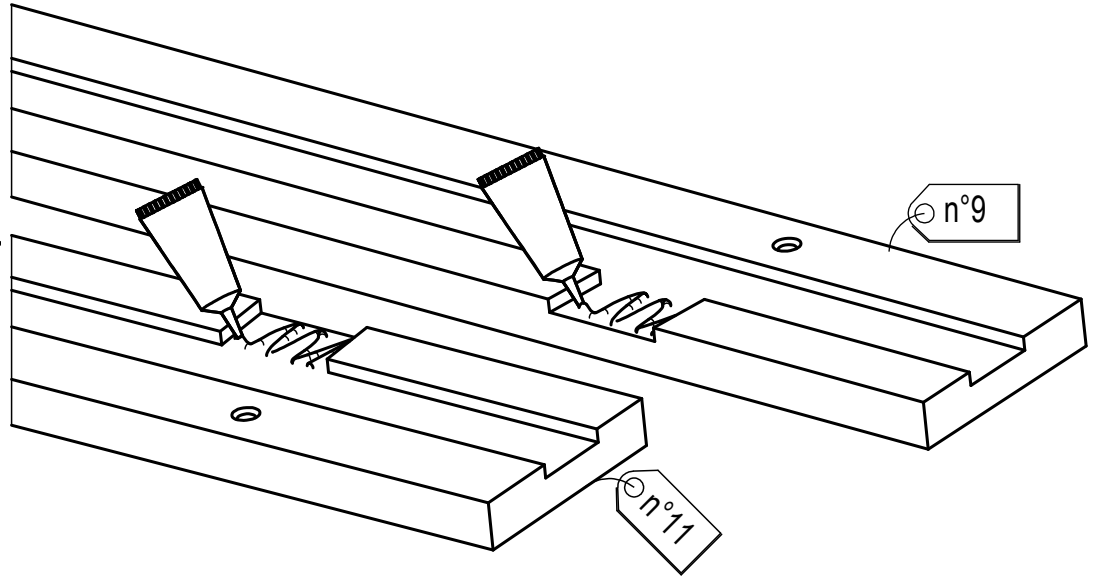
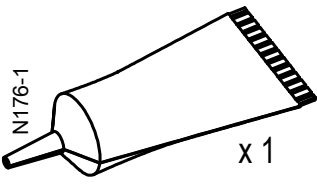

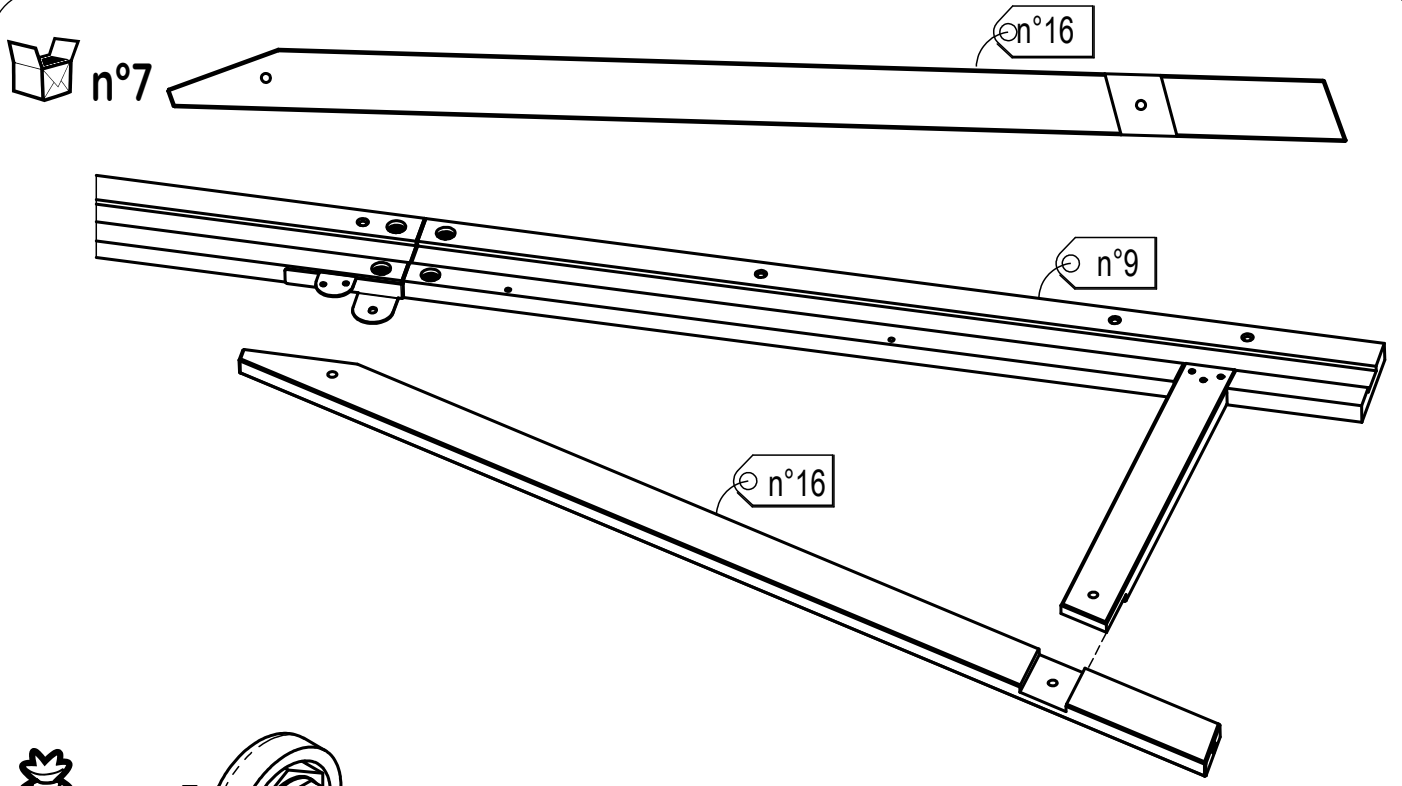

n°1

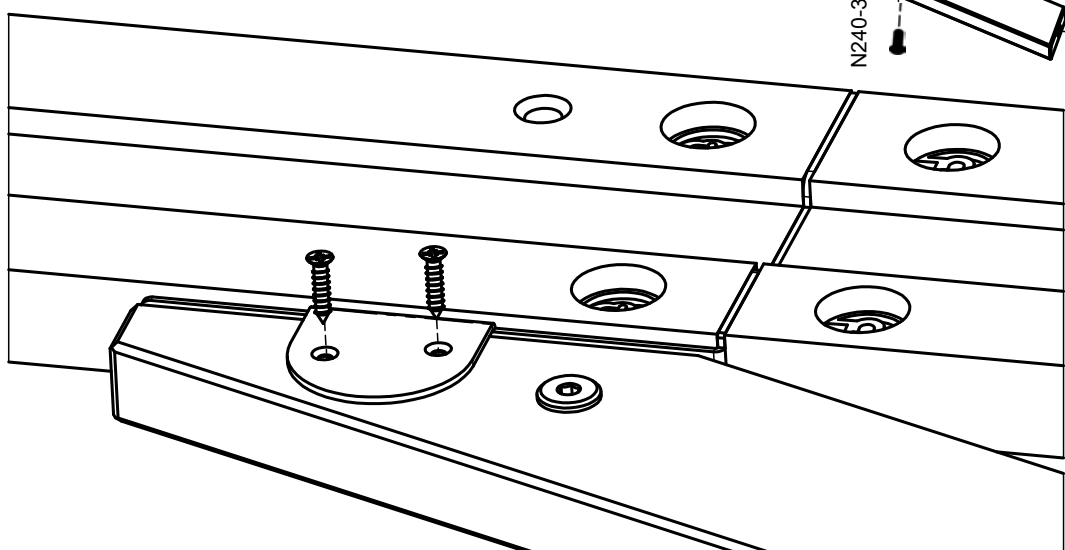
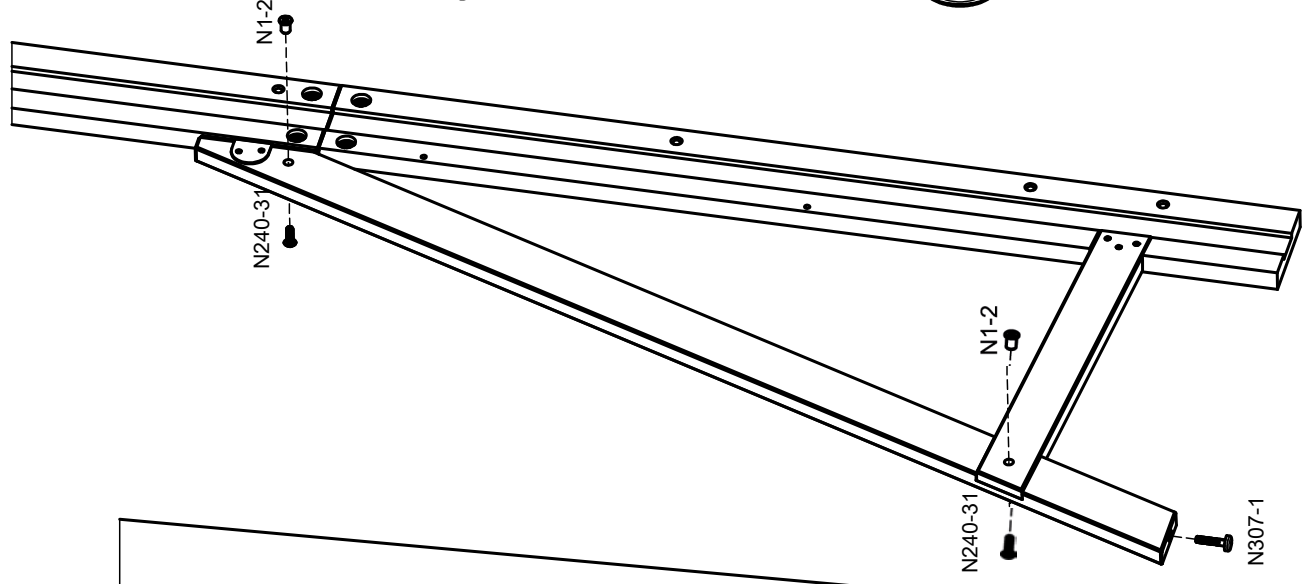
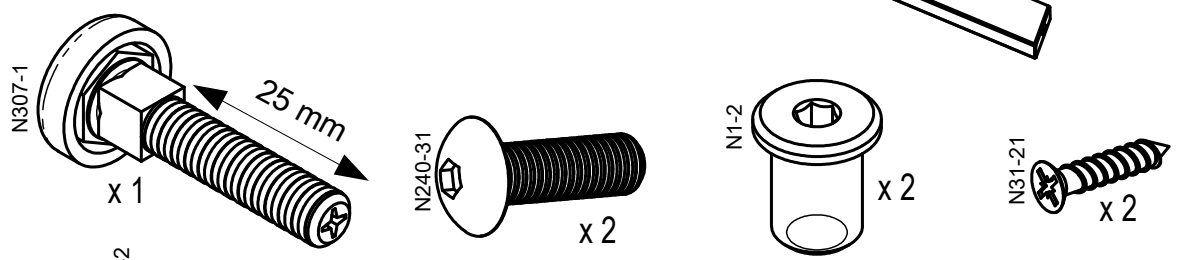



n°7

n°17

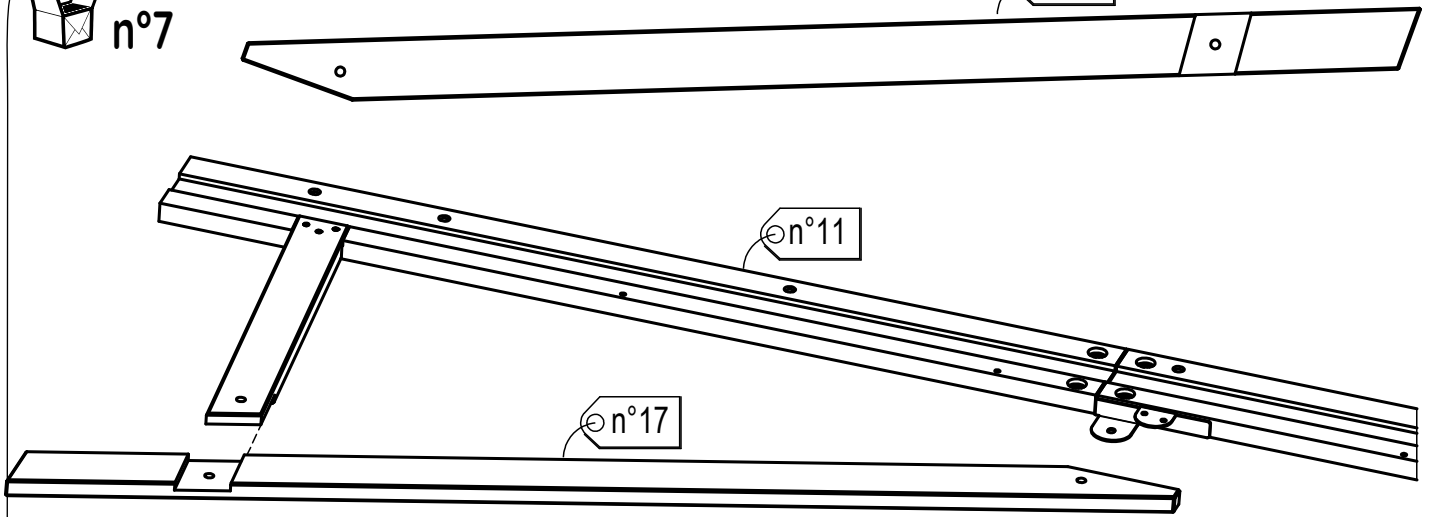

n°11

n°17



n°1

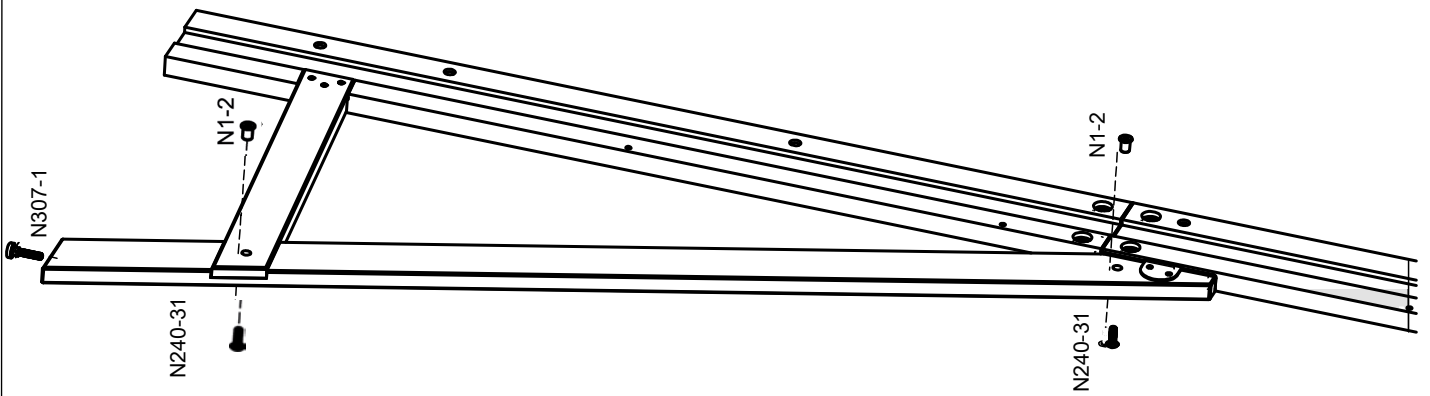
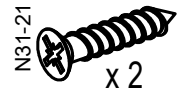
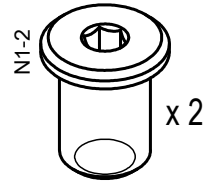
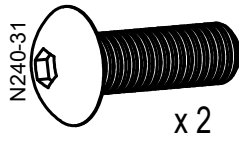
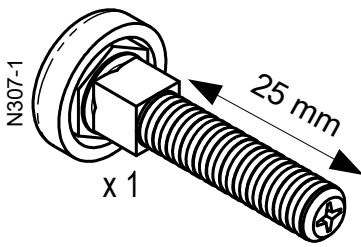

N307-1
N240-31

N1-2

N1-2
N240-31

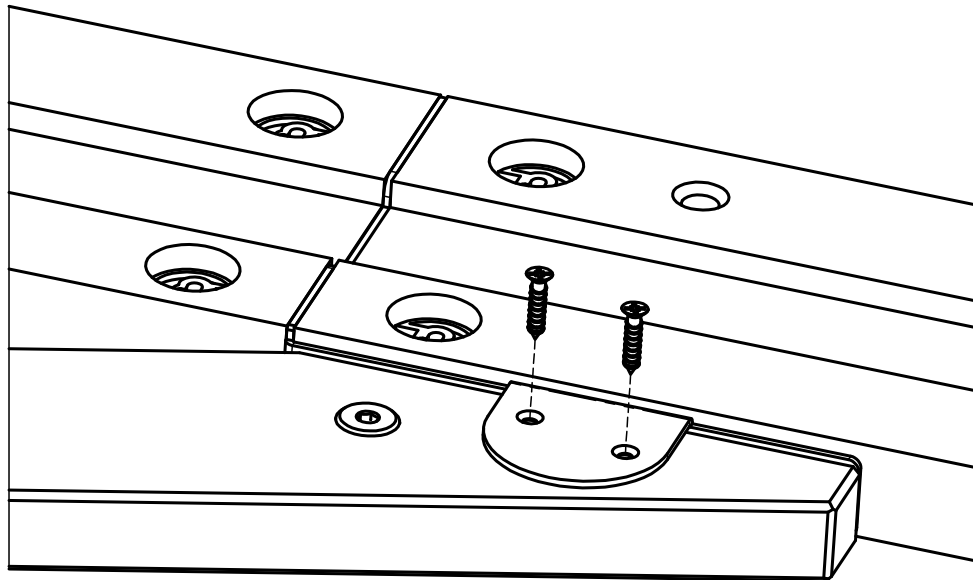

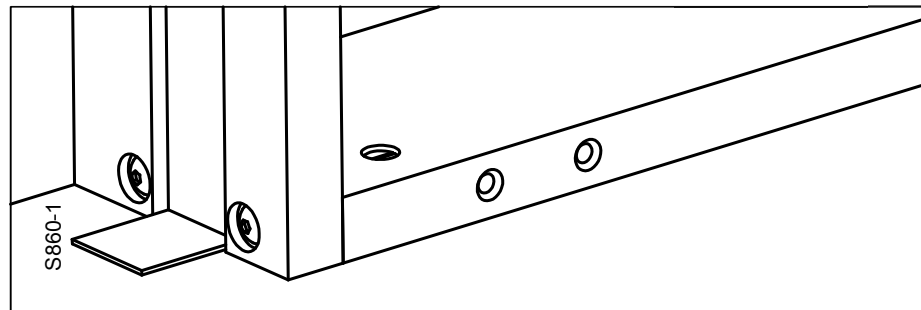
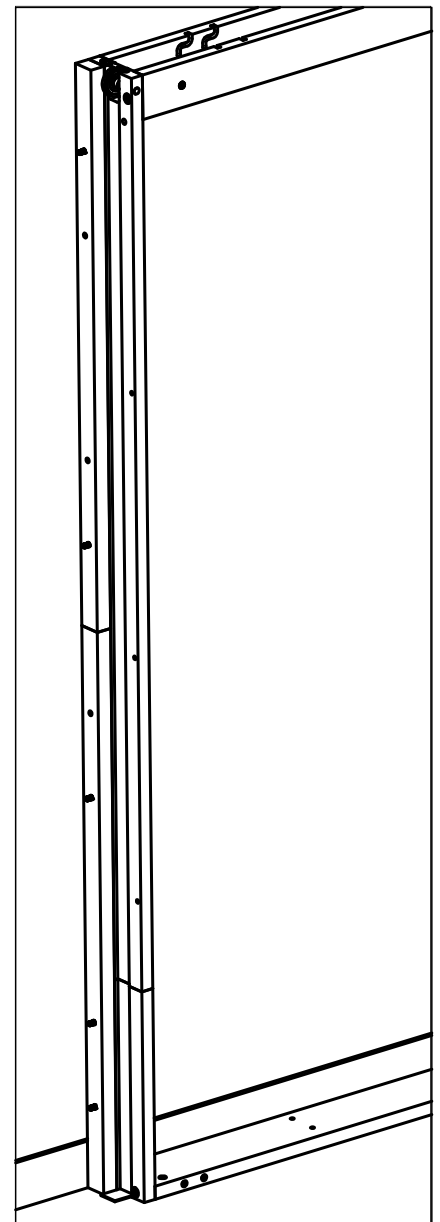
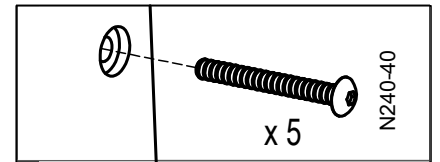
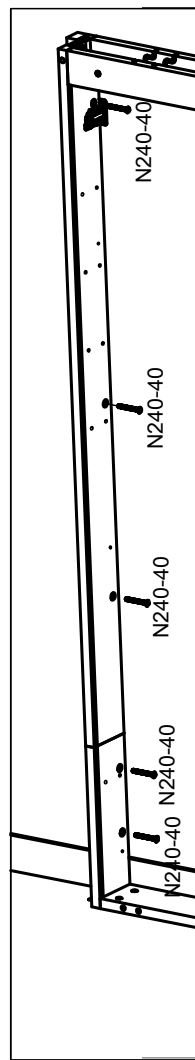
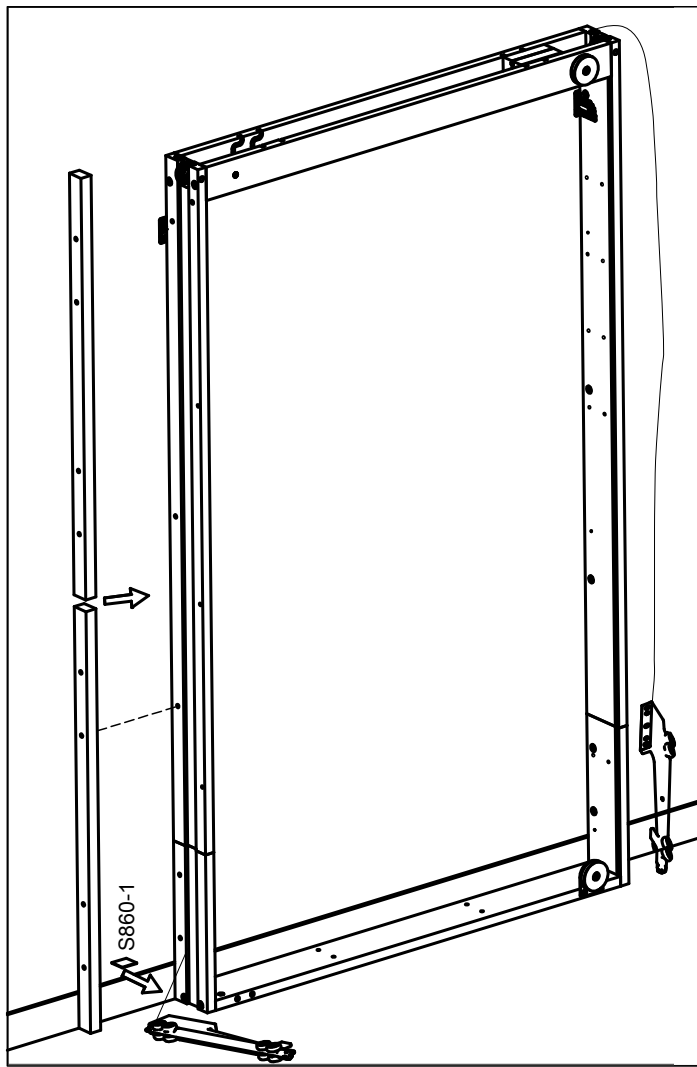
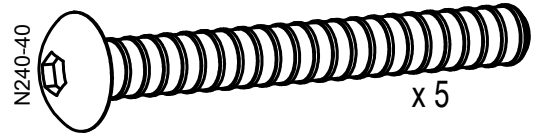
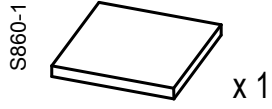
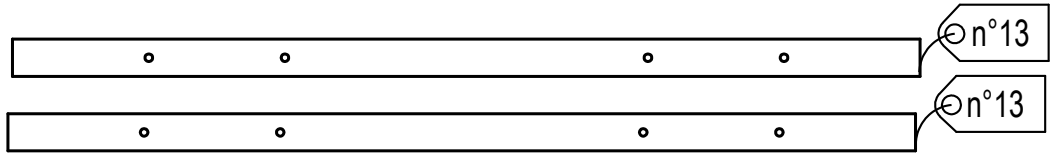

 n°7 S823-1

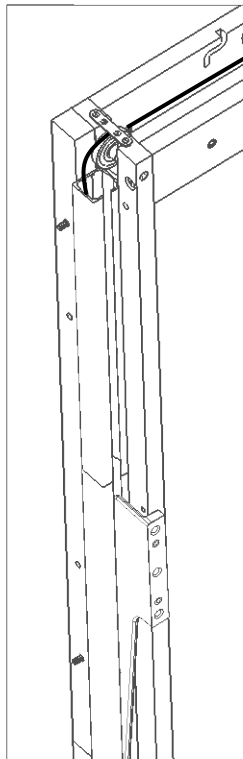
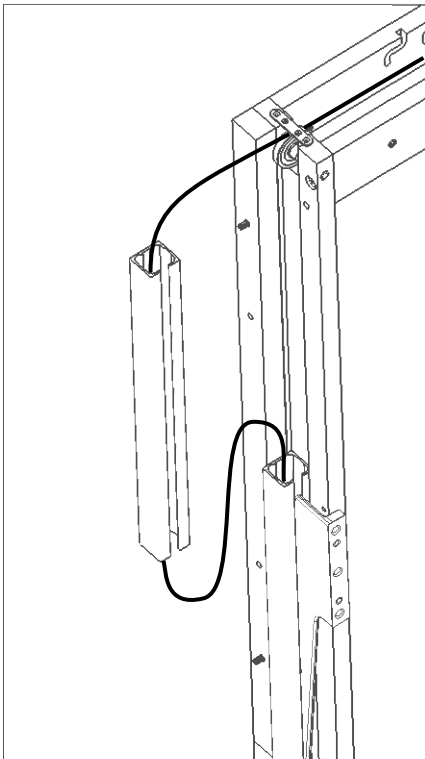
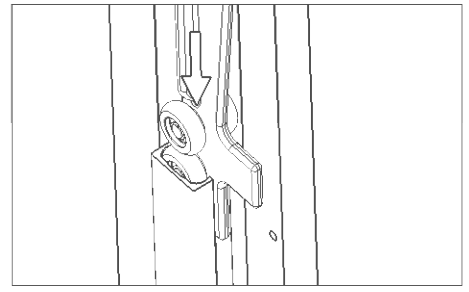
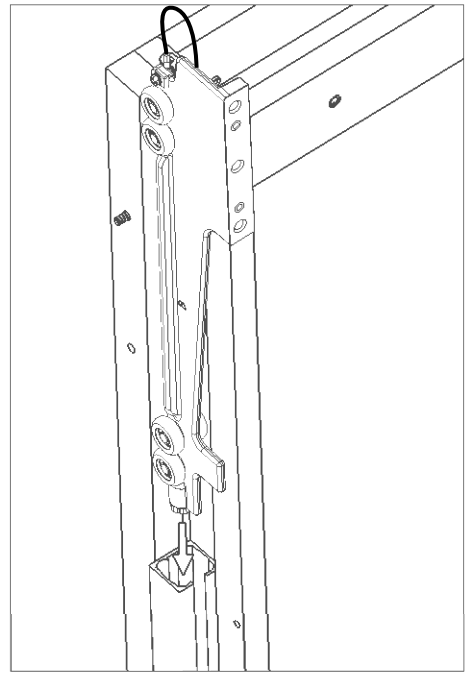
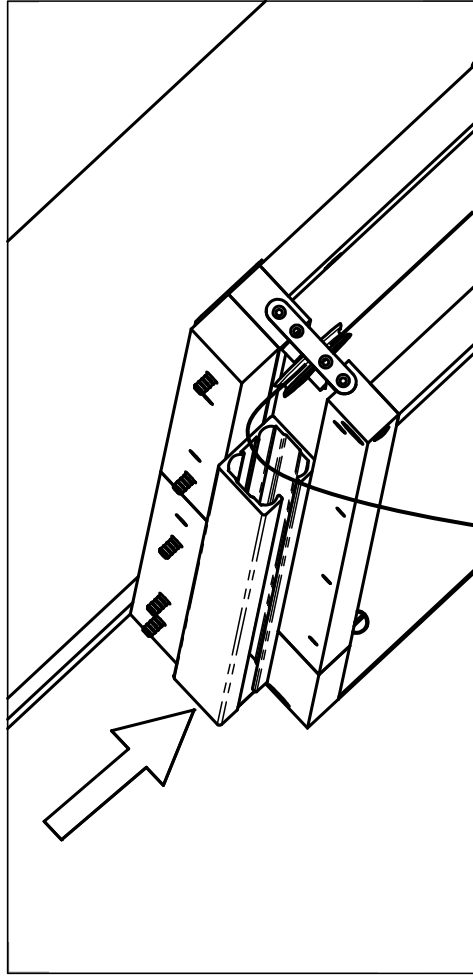
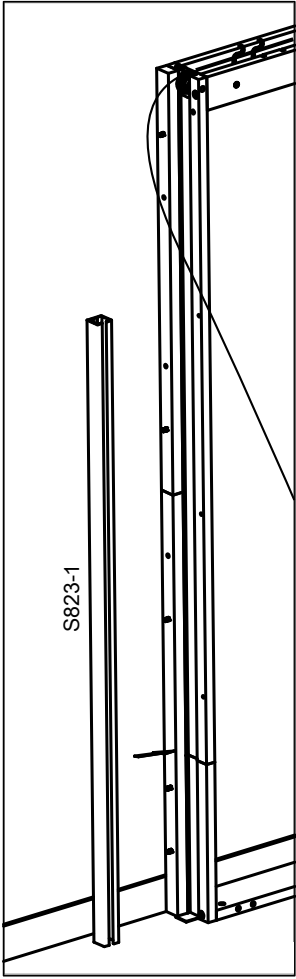
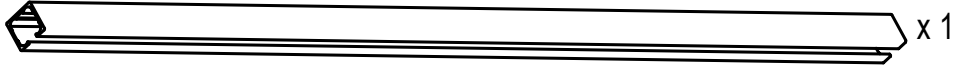

 n°6

S823-2

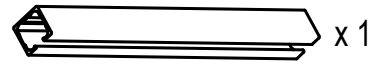



n°1

S835-1

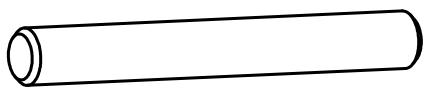

x1

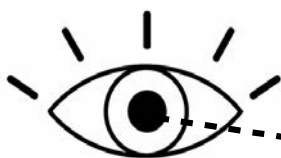

don't forget
blockers

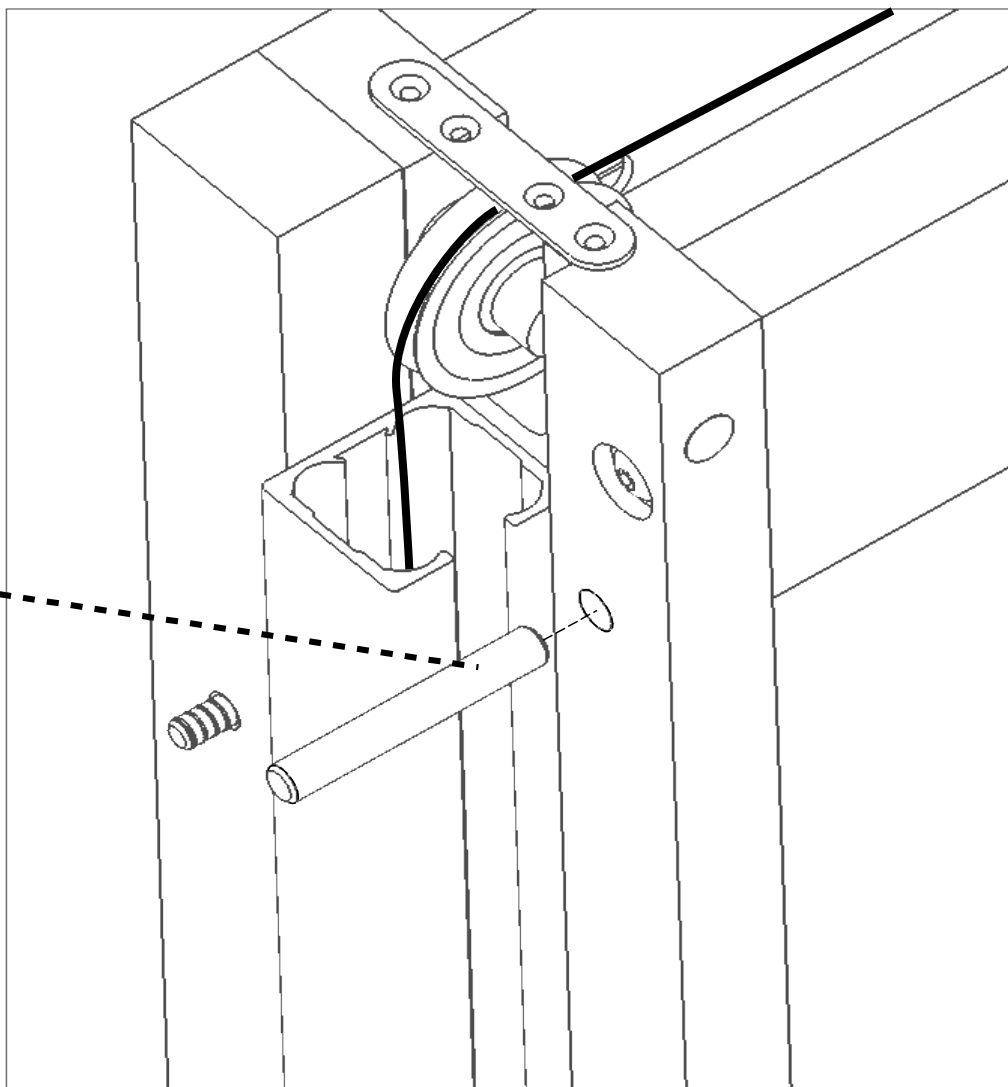

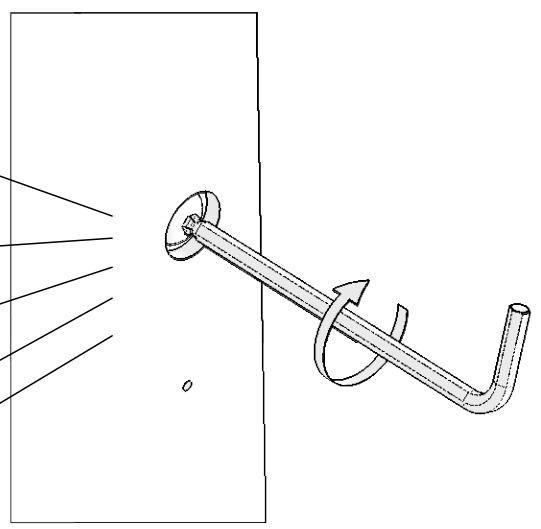
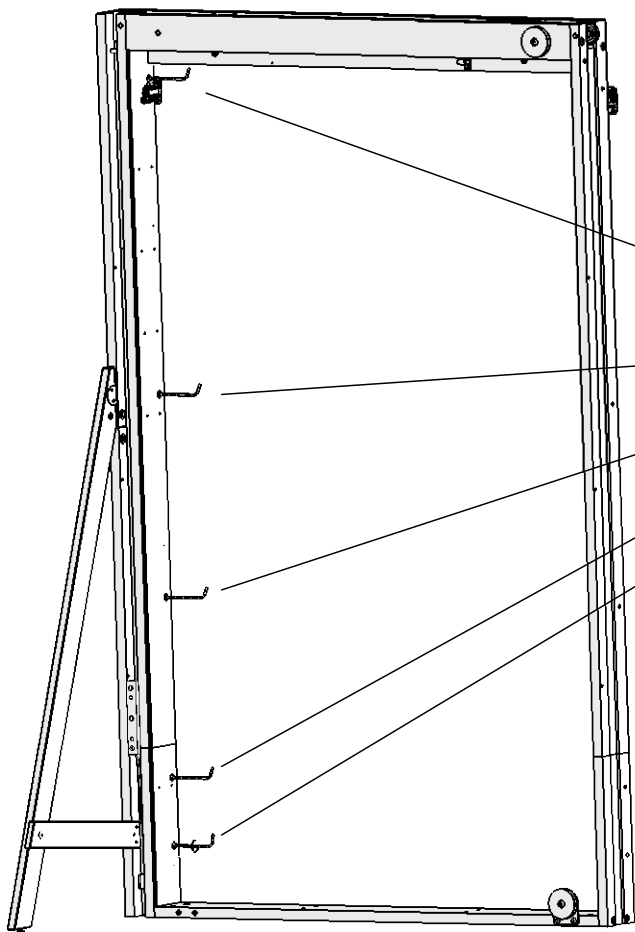
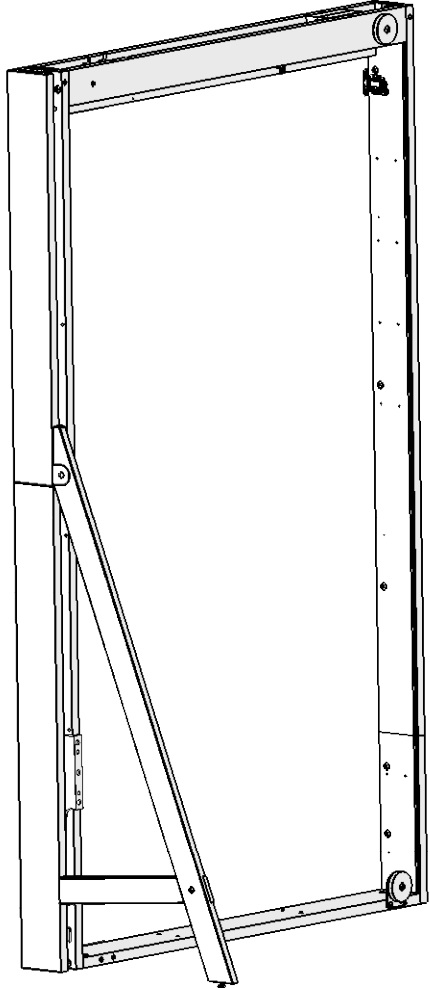
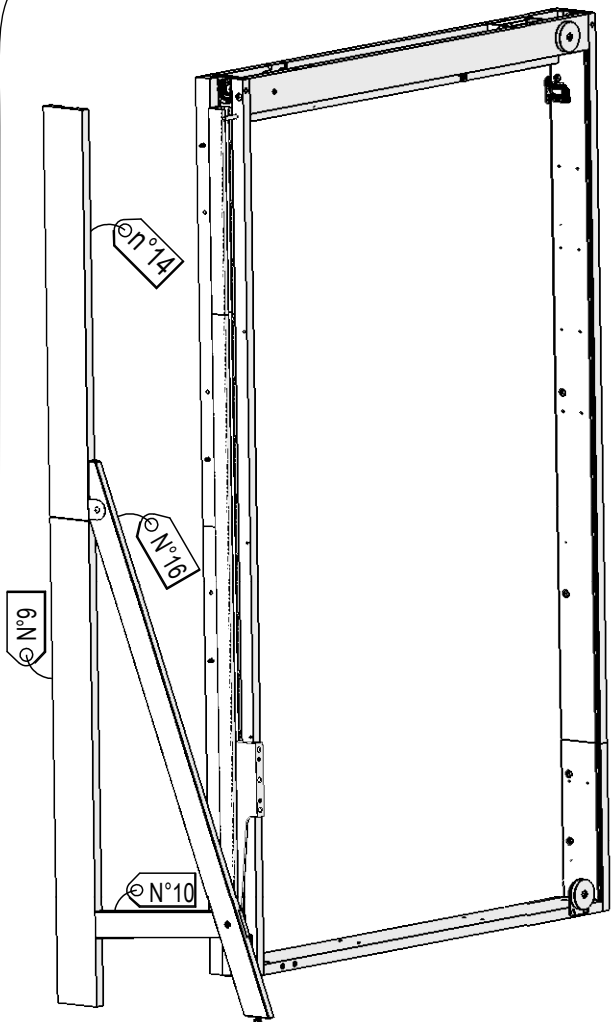

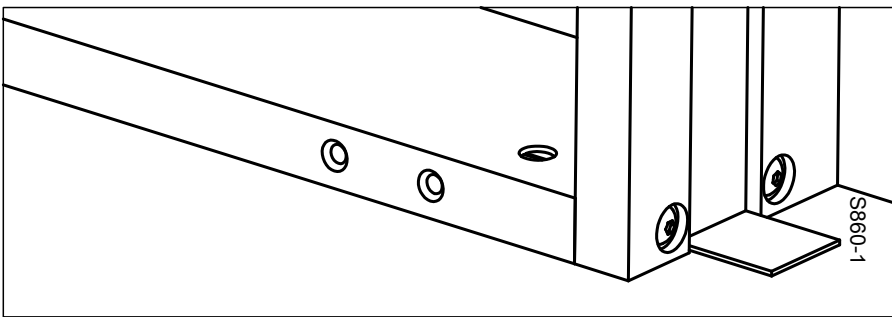
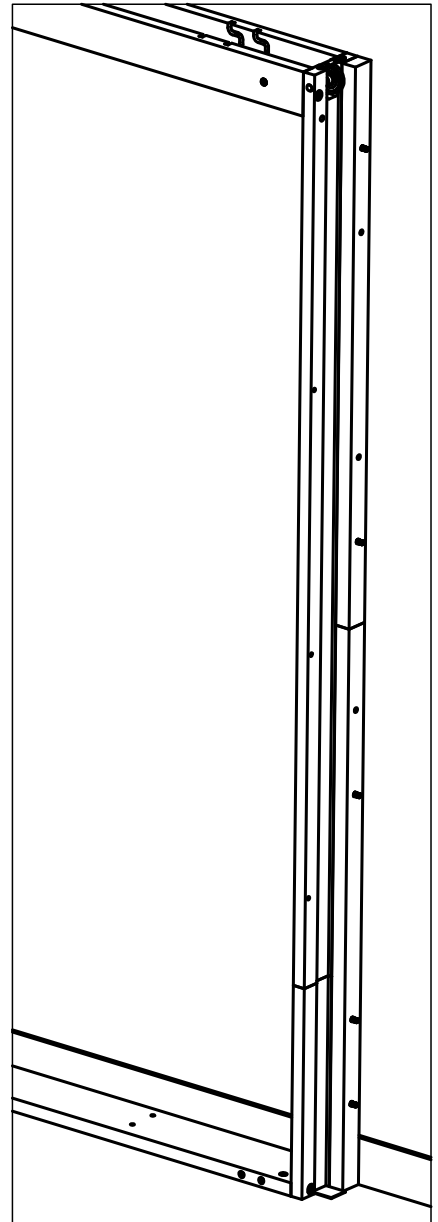
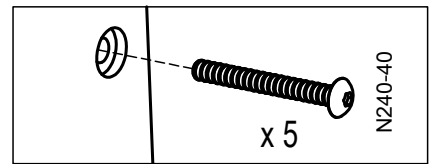
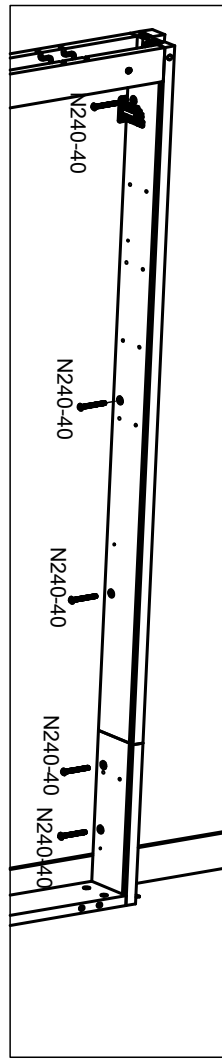
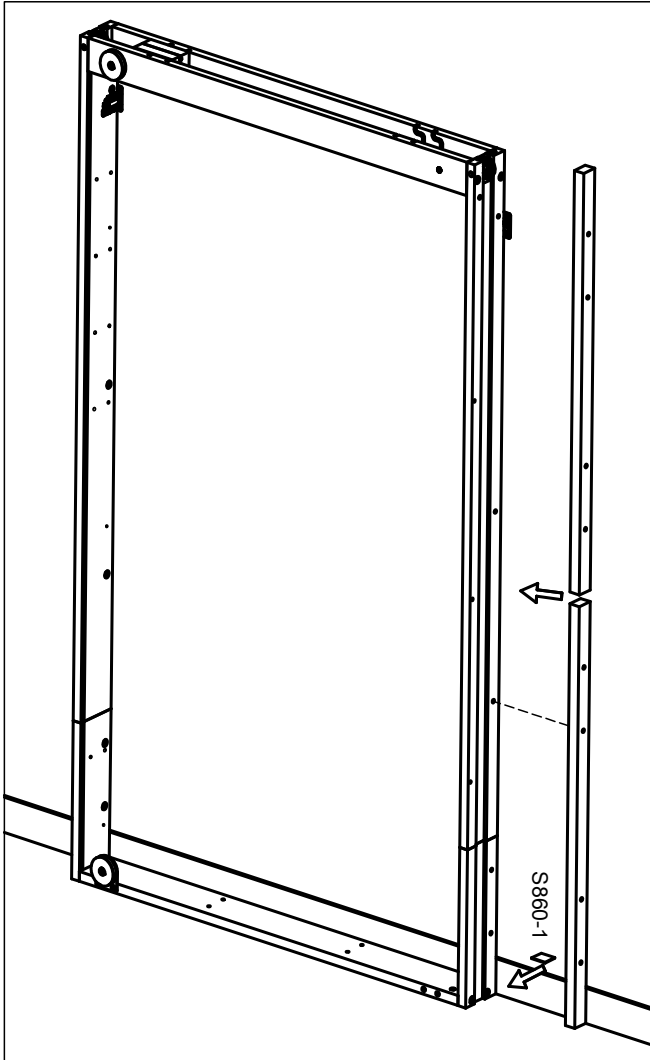
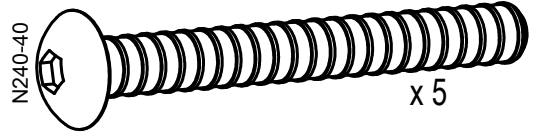
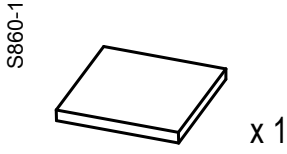
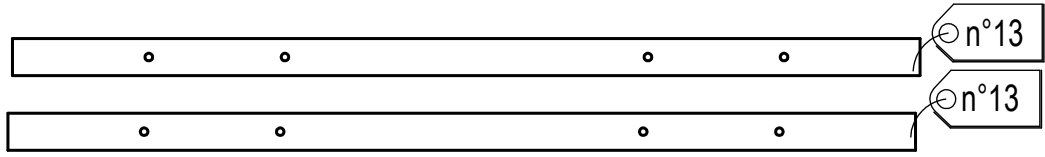

 n°7

S823-1

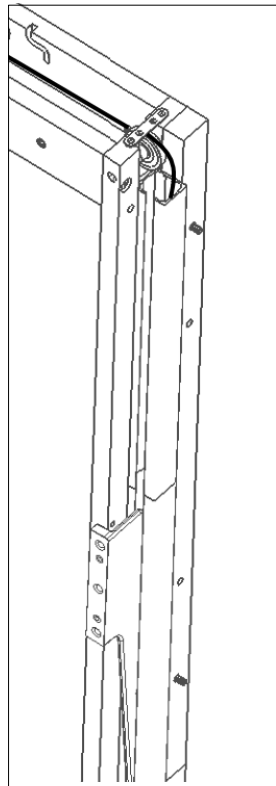
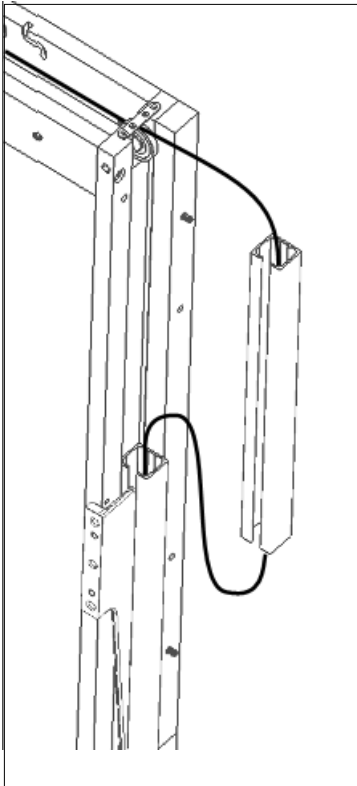
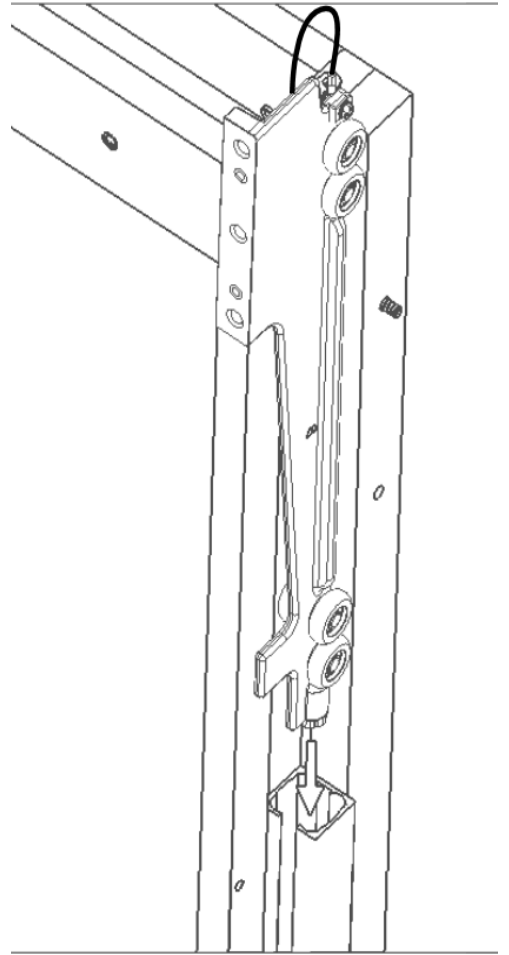
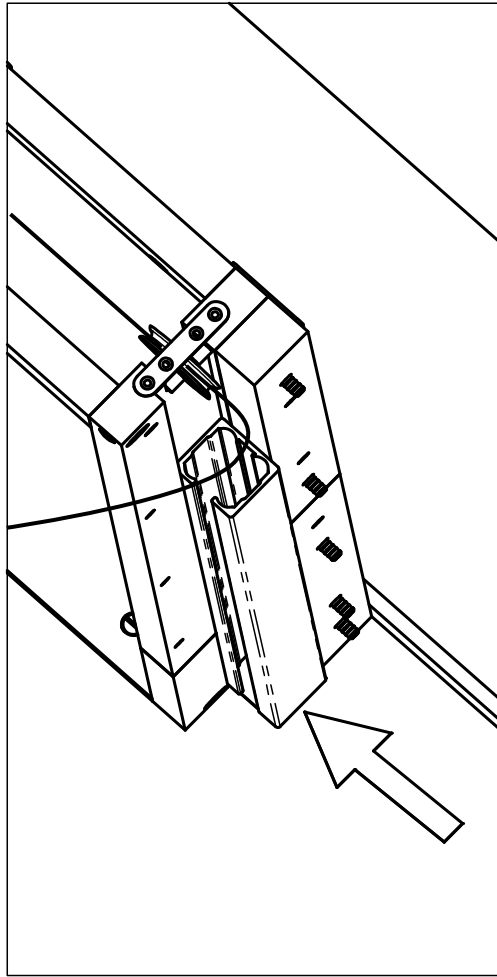
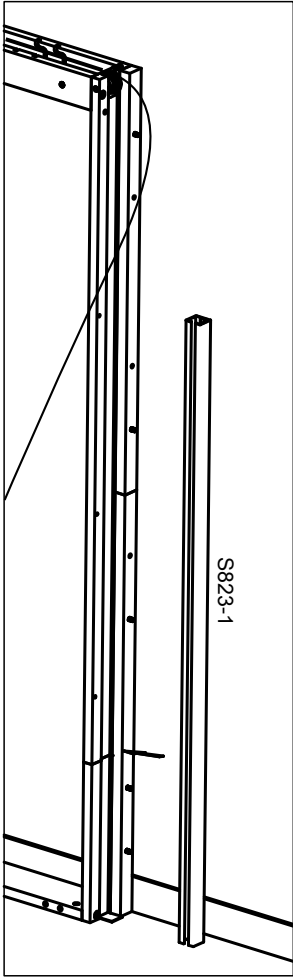
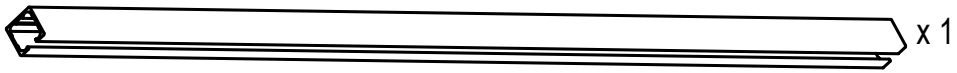

 n°6

S823-2

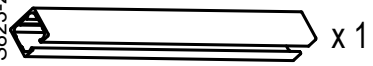



n°1

S835-1

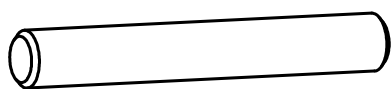

x 1



don't forget
blockers

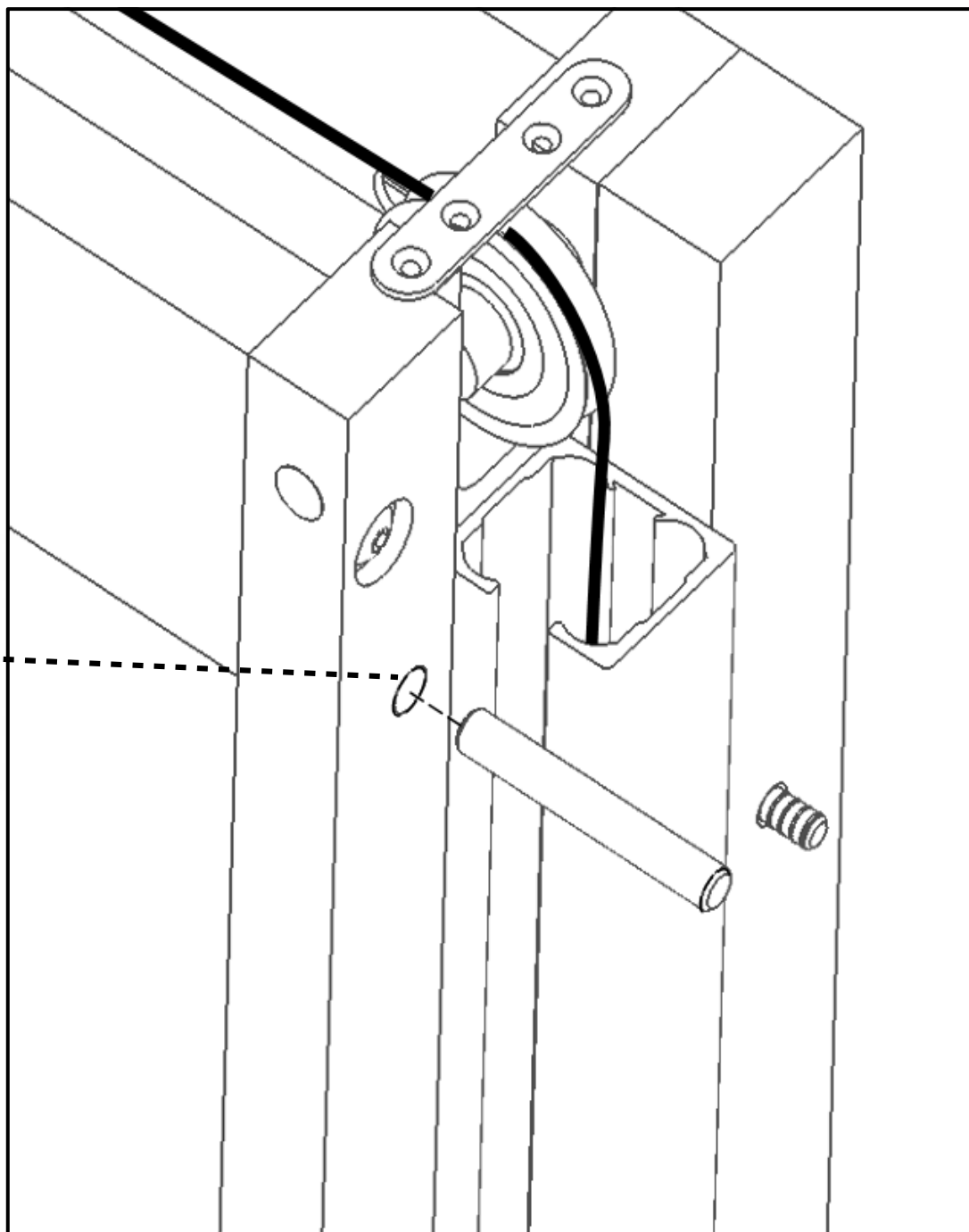

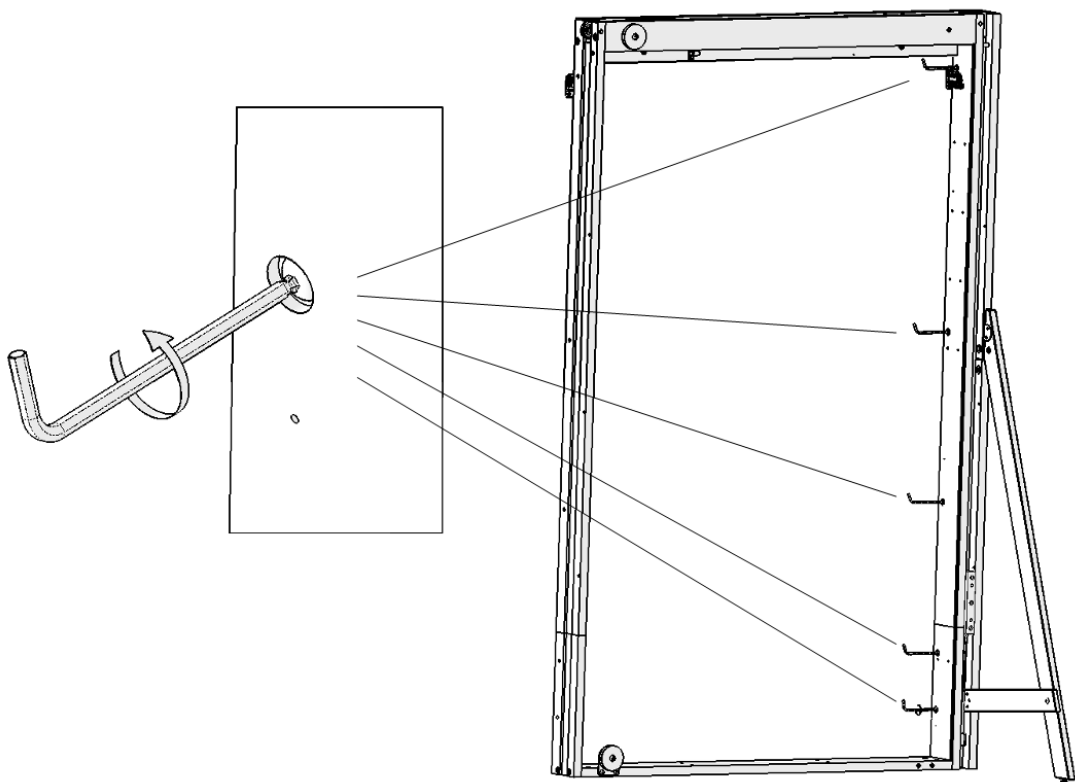
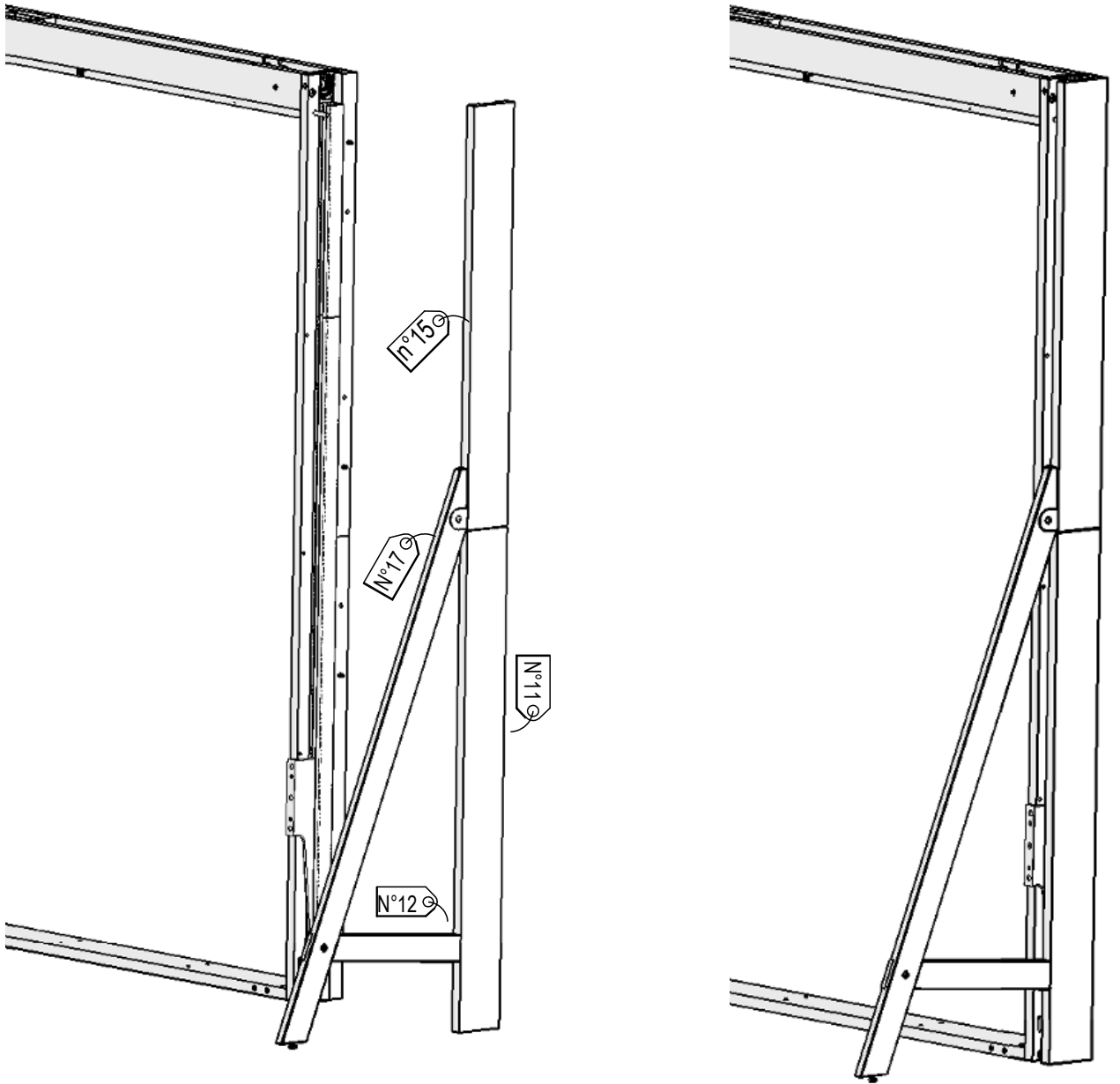

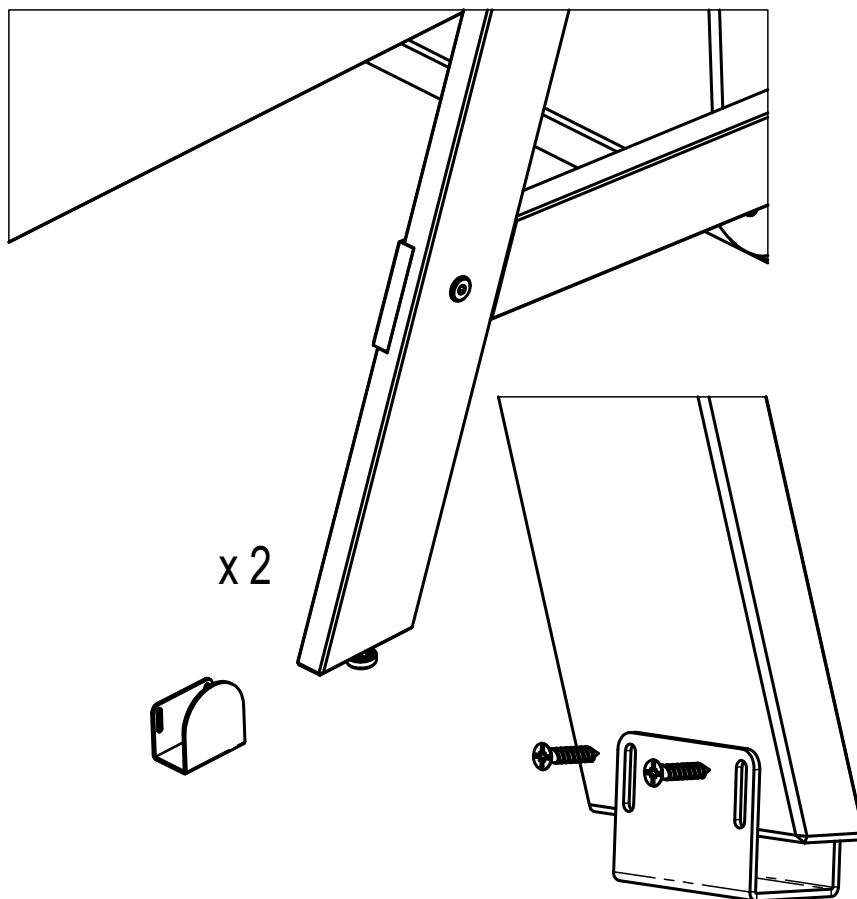
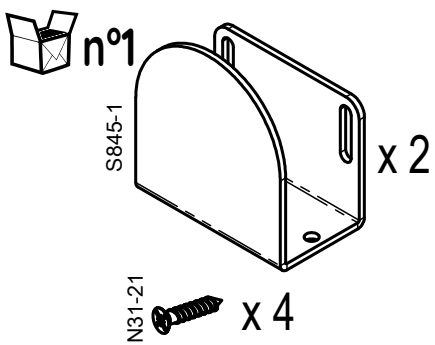
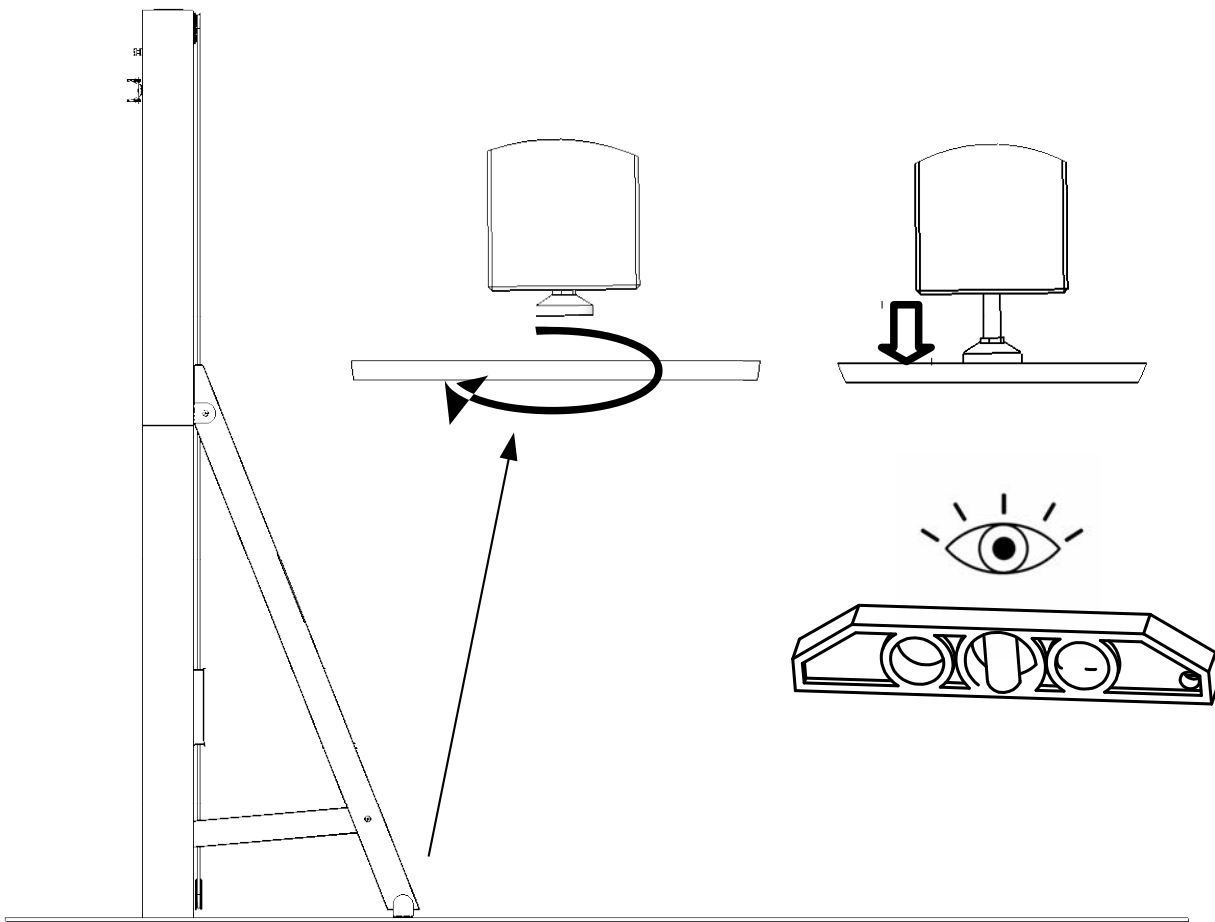

n°7

x 1



N31-21

x 3

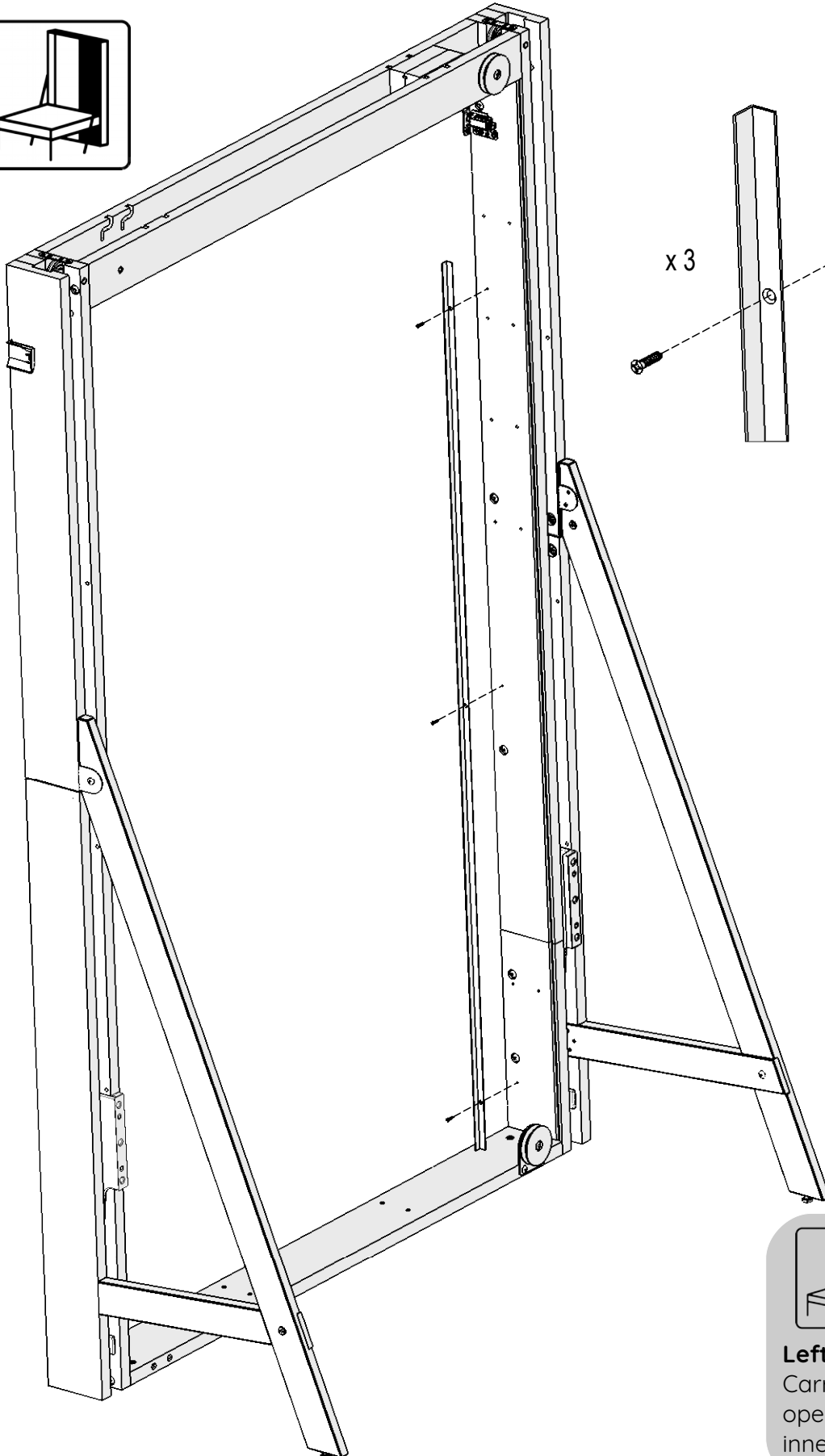

x 3

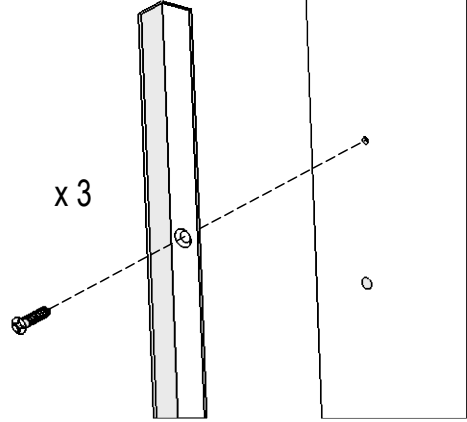

Left-hand counterweight:
Carry out the same operation on the left-hand inner upright

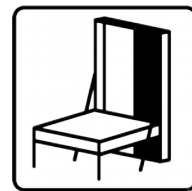

Counterweight left :
Follow the same
steps

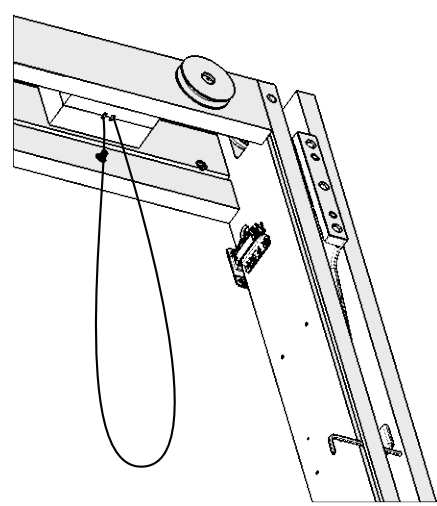
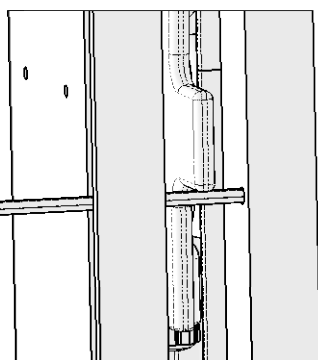
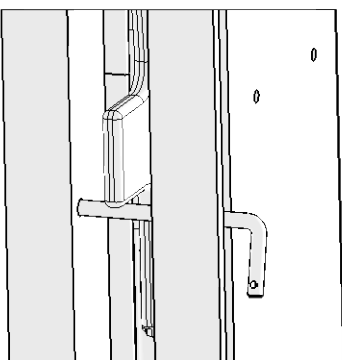
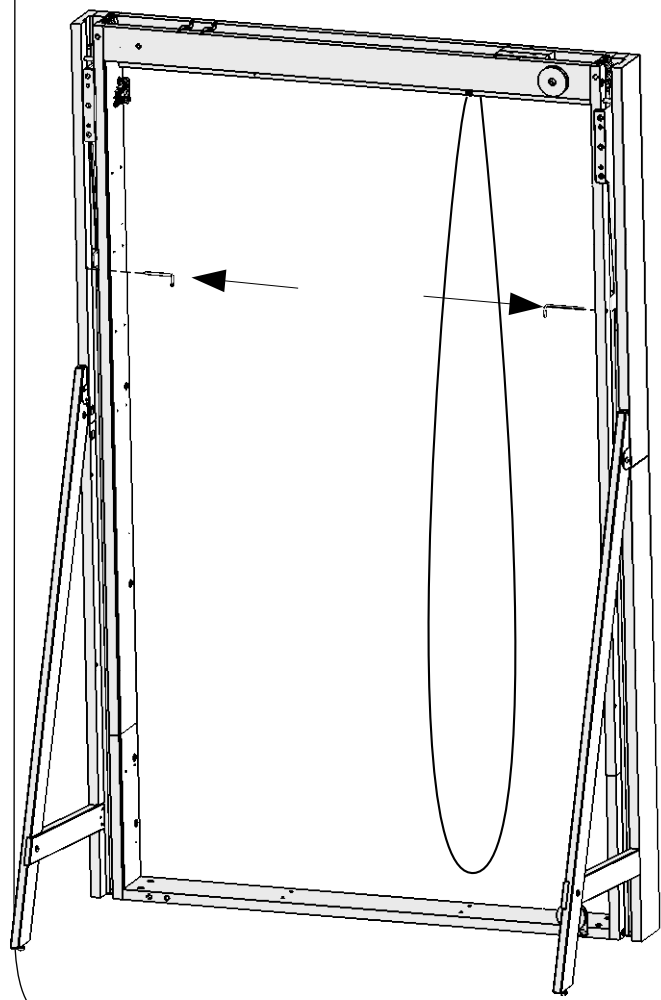
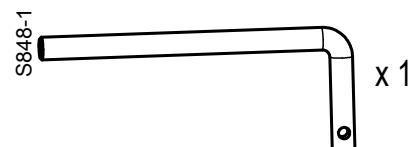
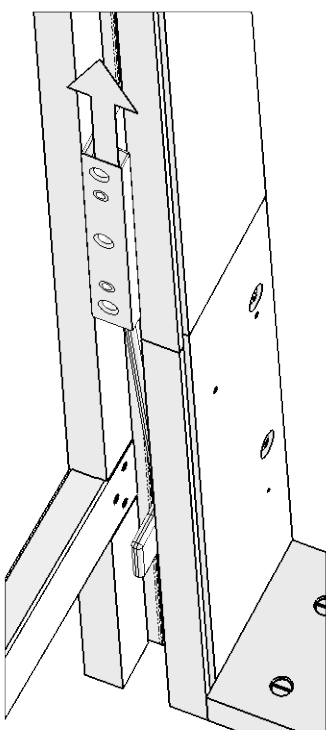
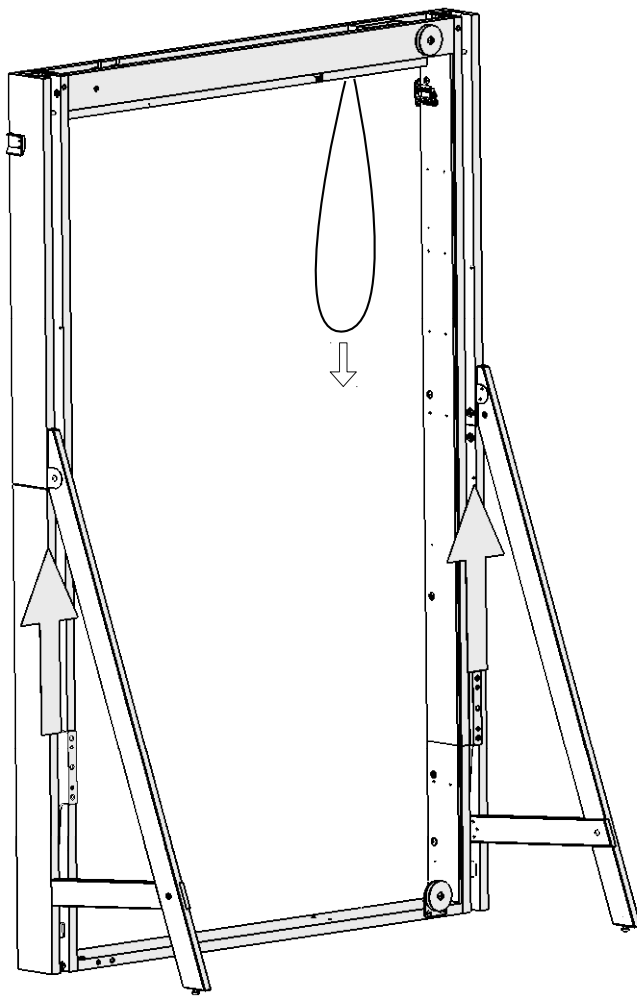

 n°8

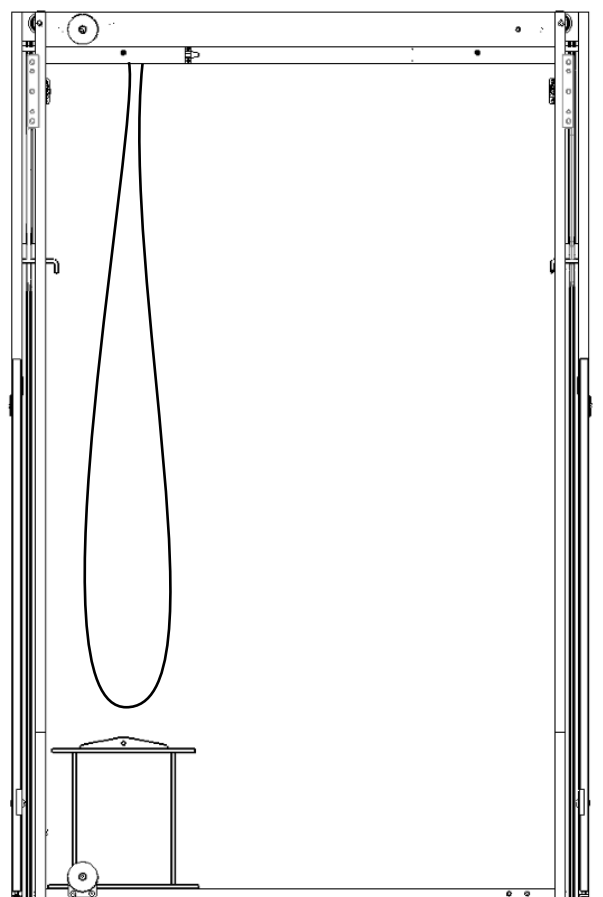
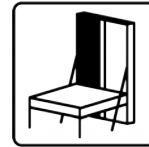
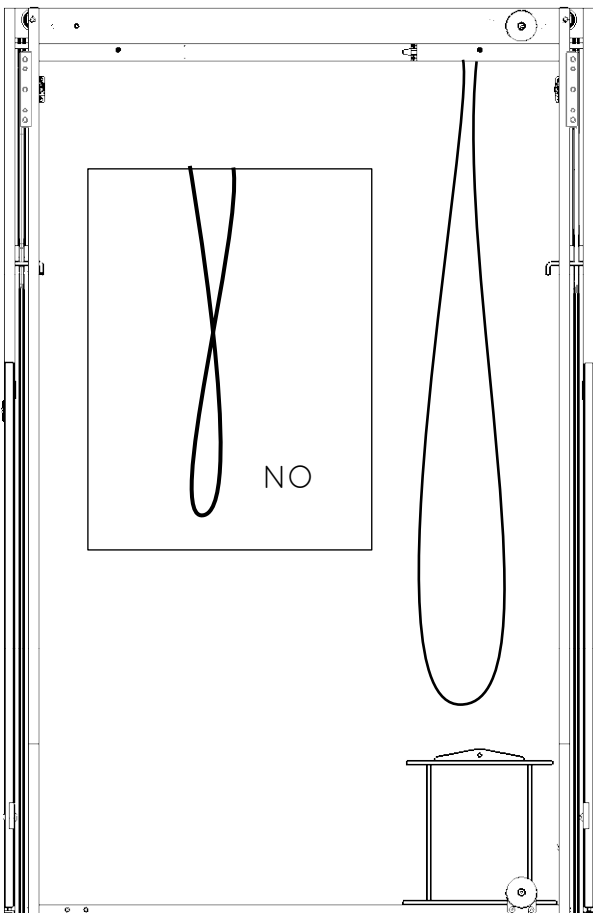
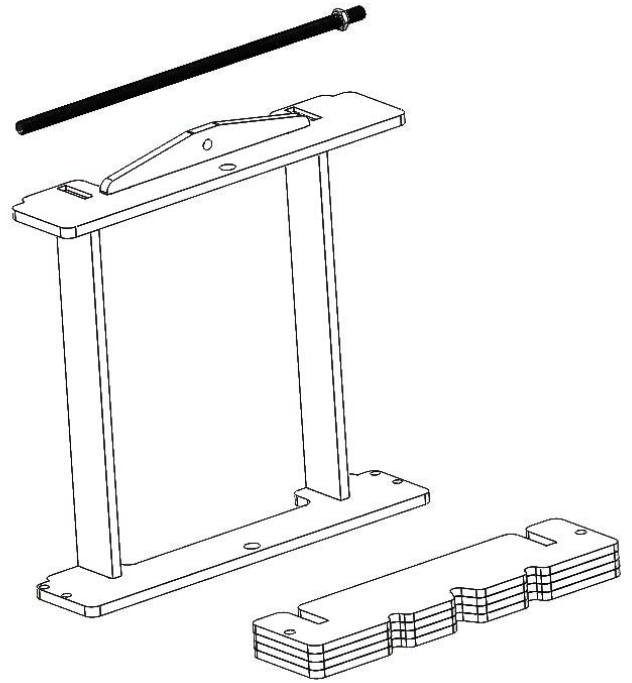
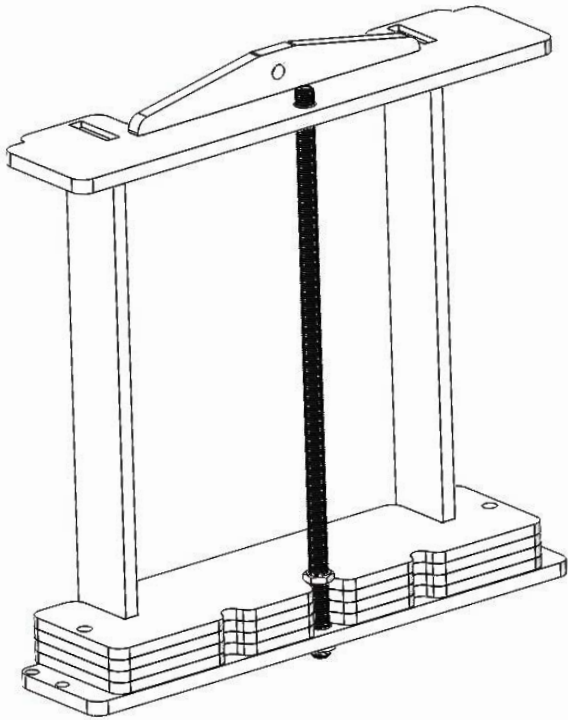



S817-11

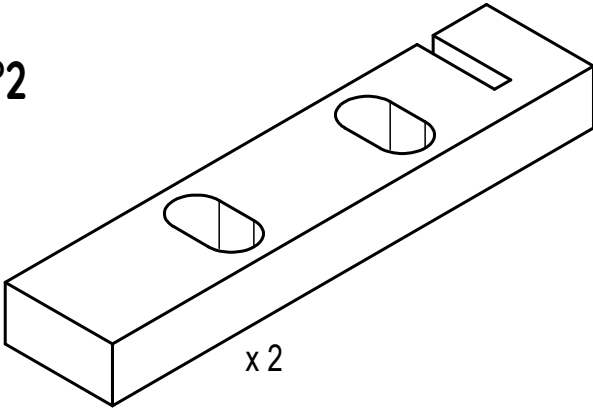

x 2



N124-9



x 4

N171-41



x 4

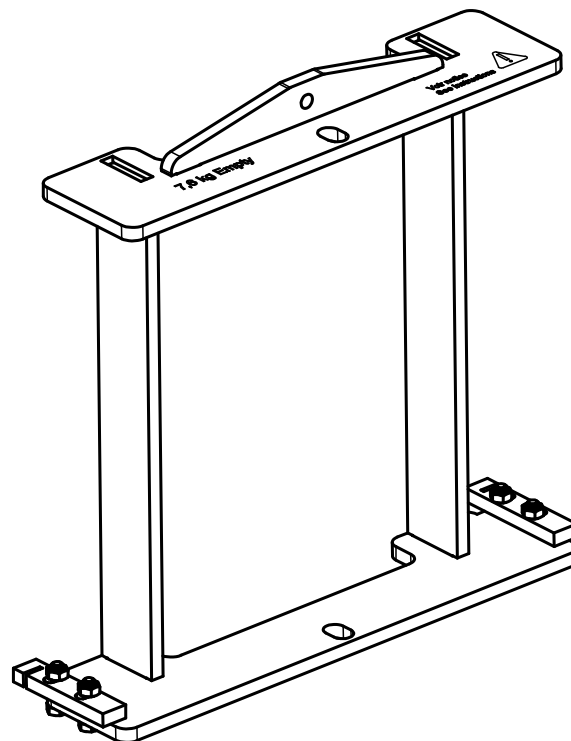
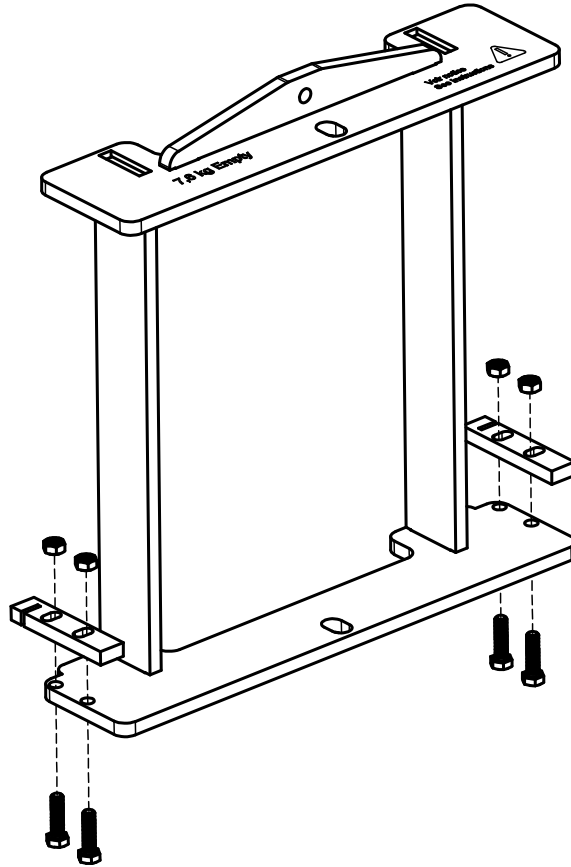



n°4

A724-1

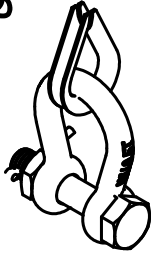

x 1

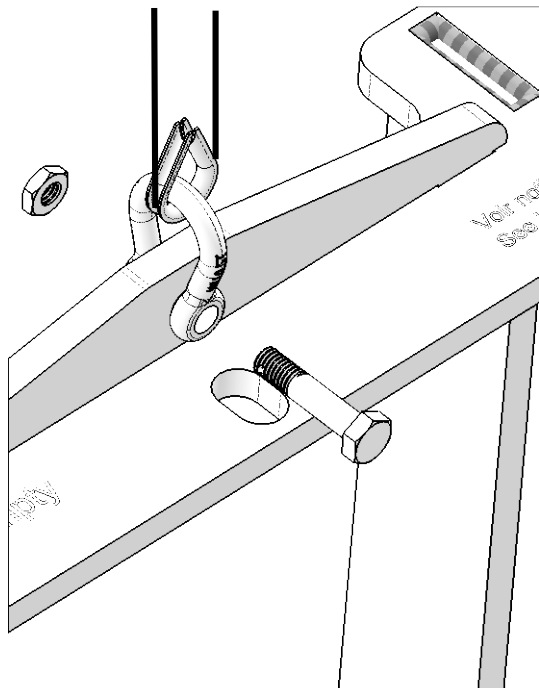
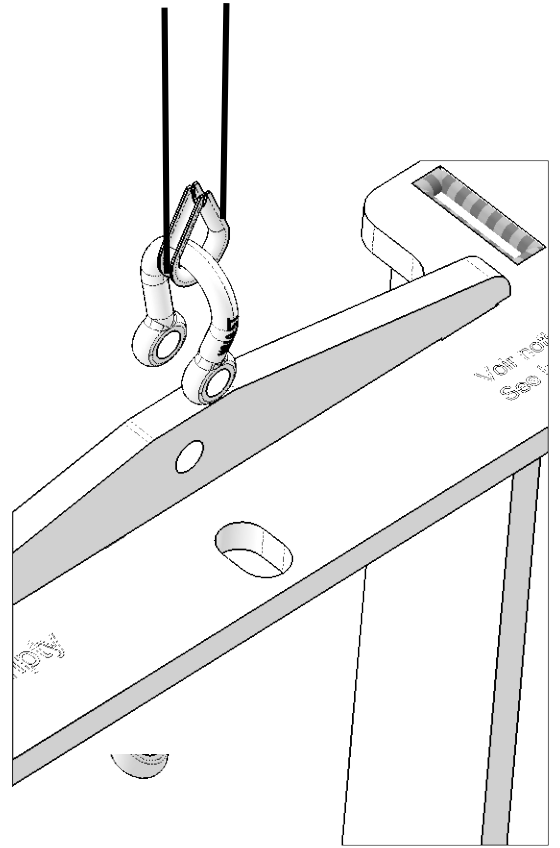
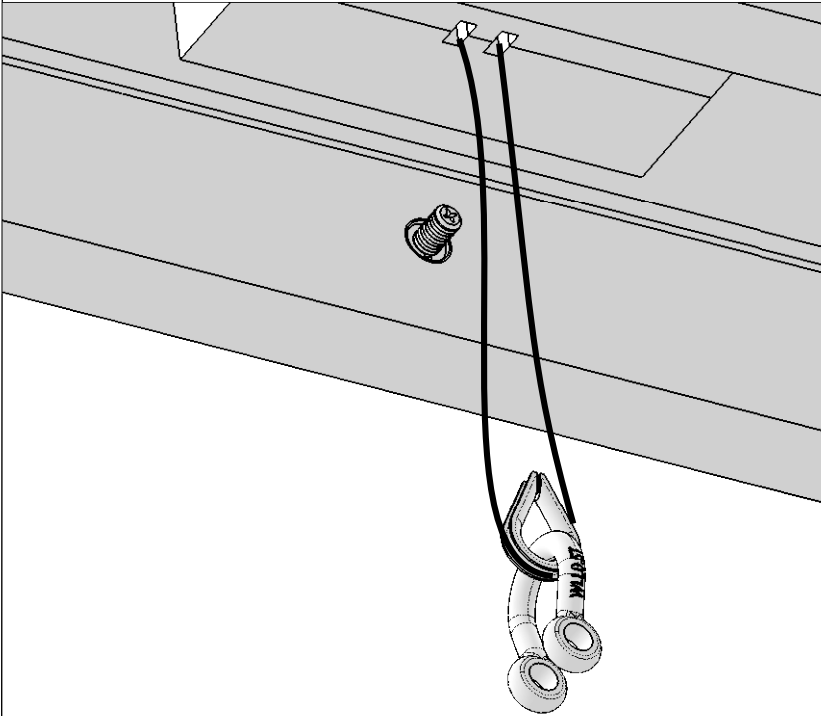
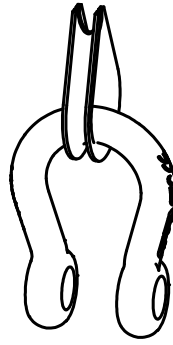

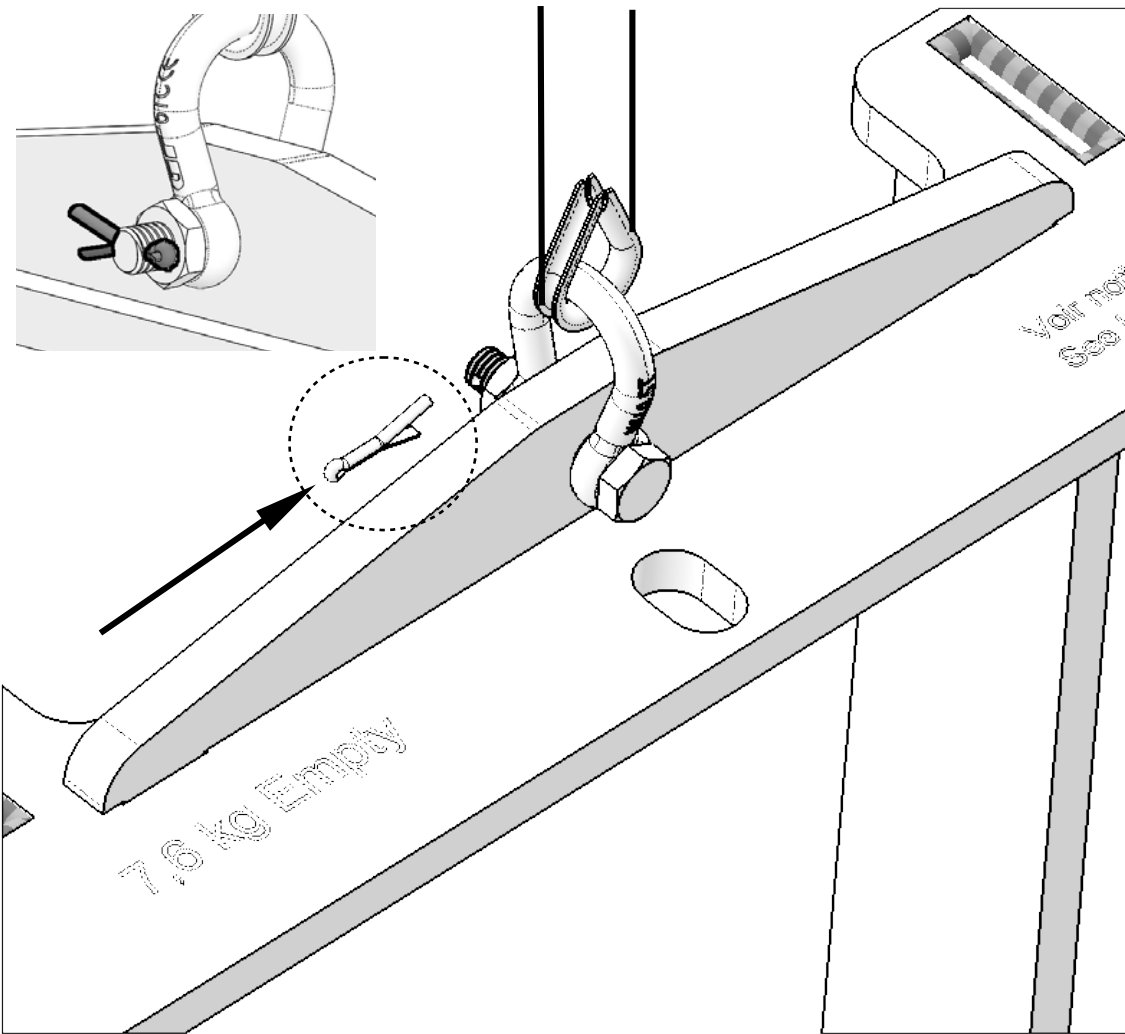
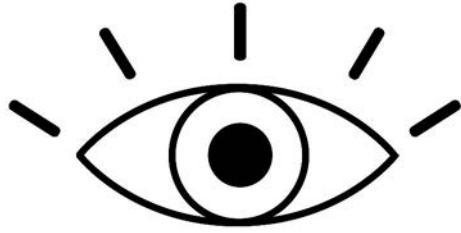

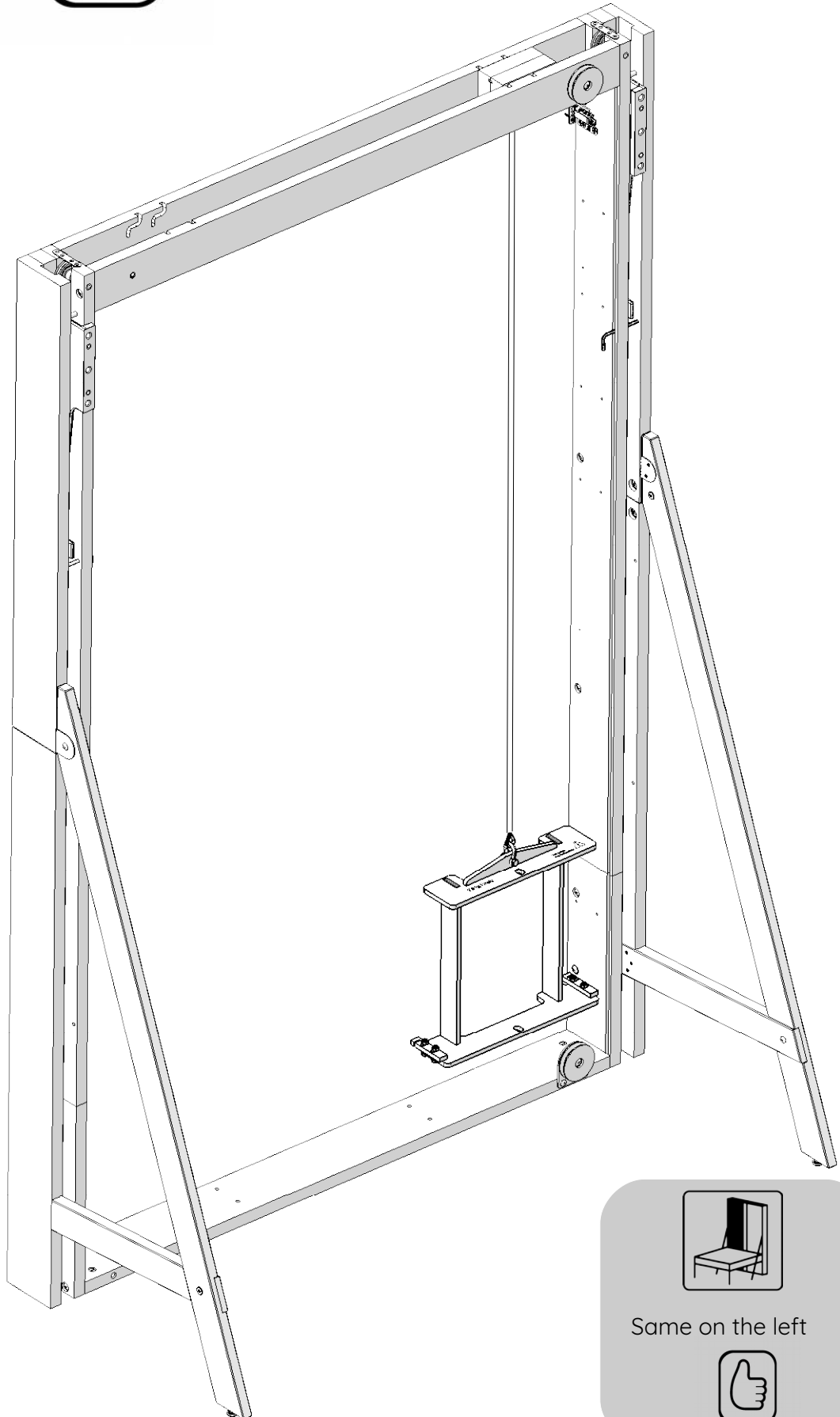

Same on the left



n°4

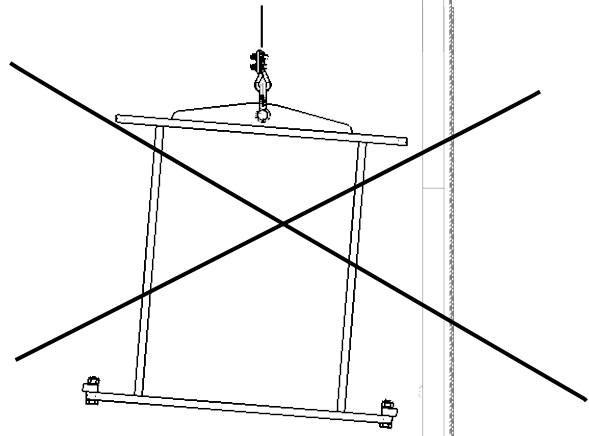
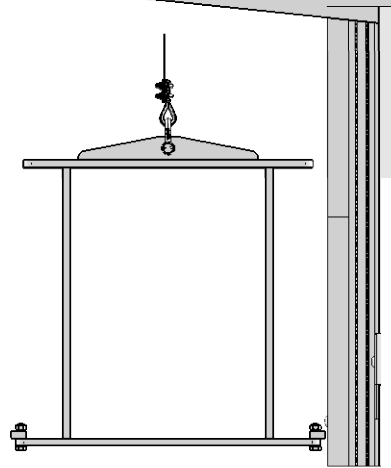
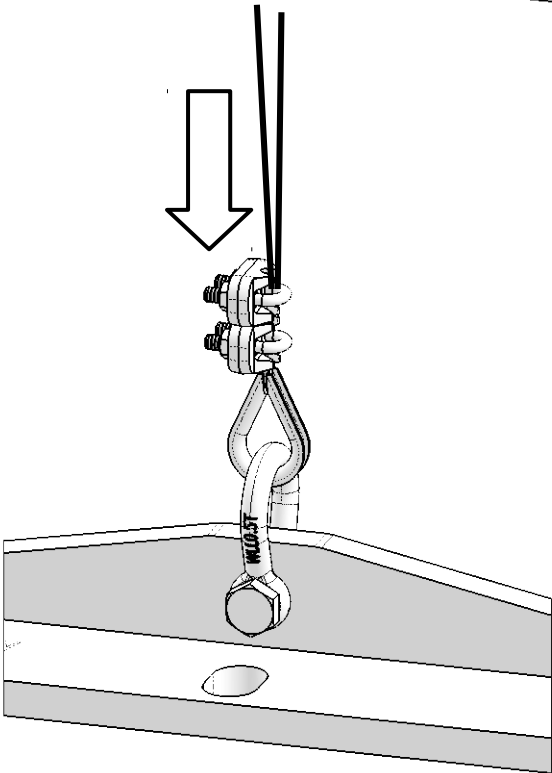
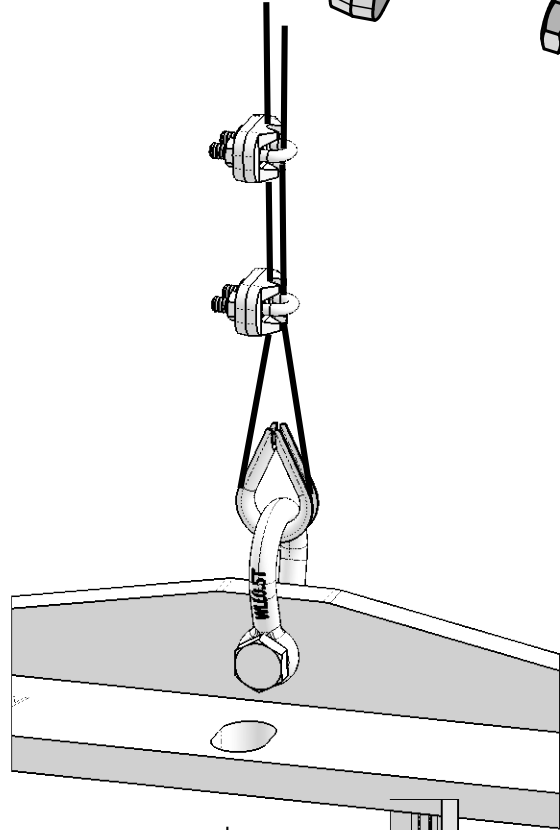
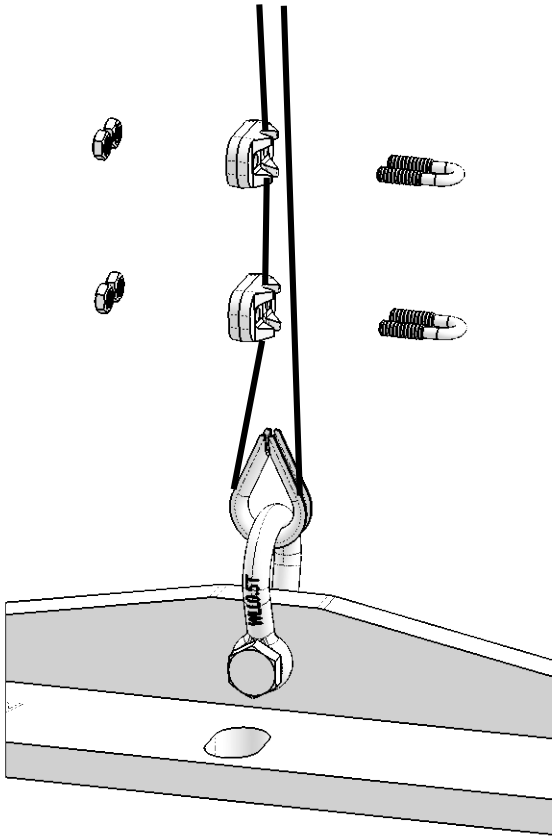
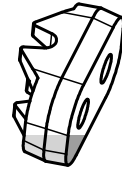
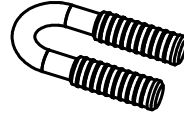
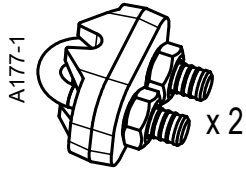



n°7



n°2



n°1

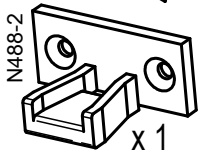

n°5



n°19

n°18

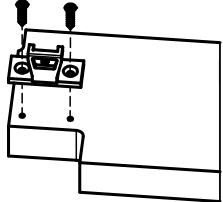
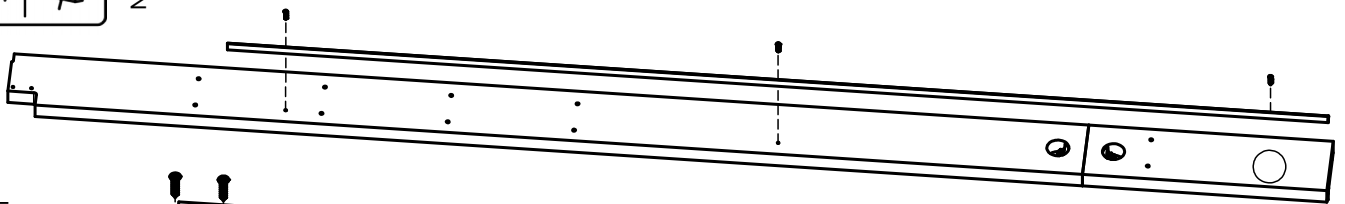
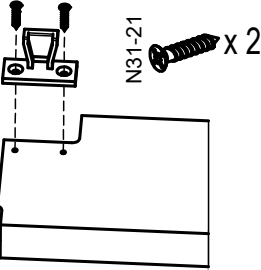
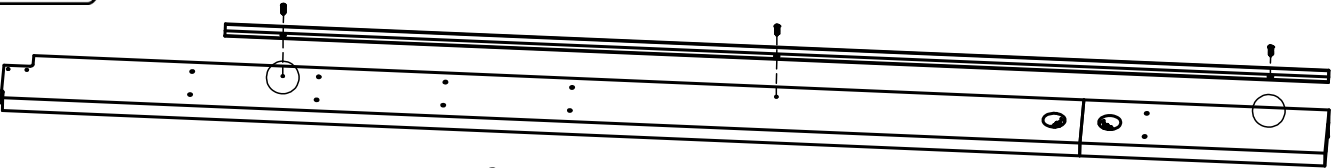
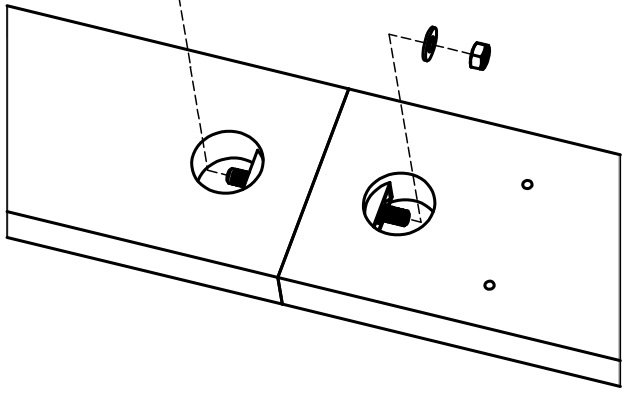
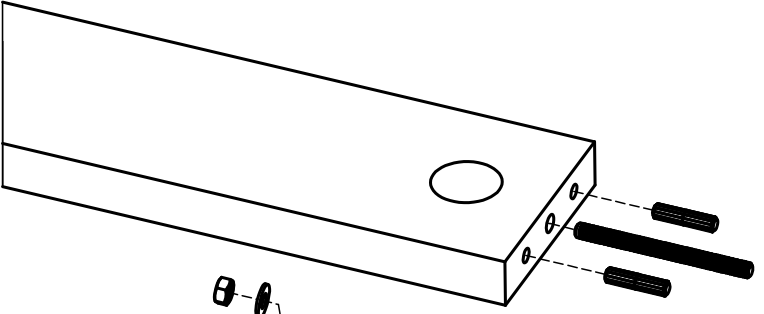
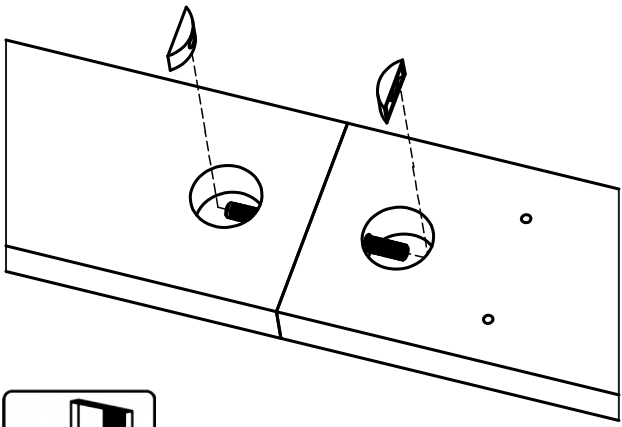



N24-8 x 2

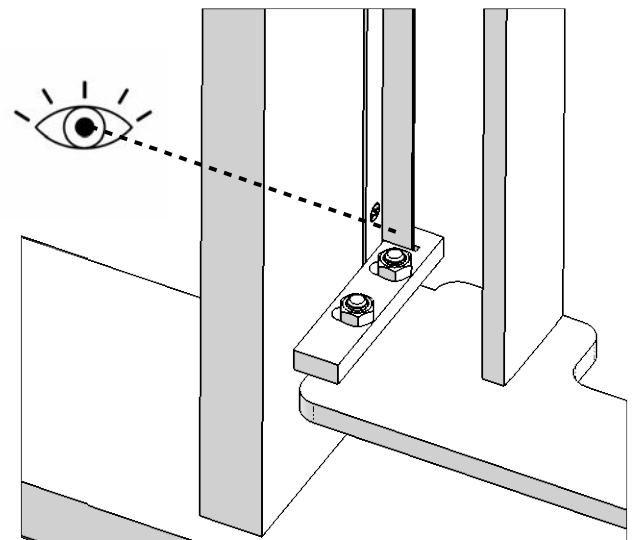
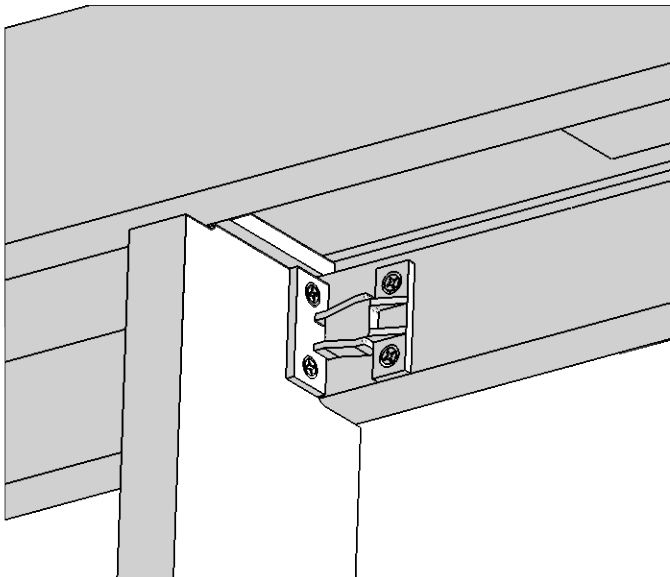
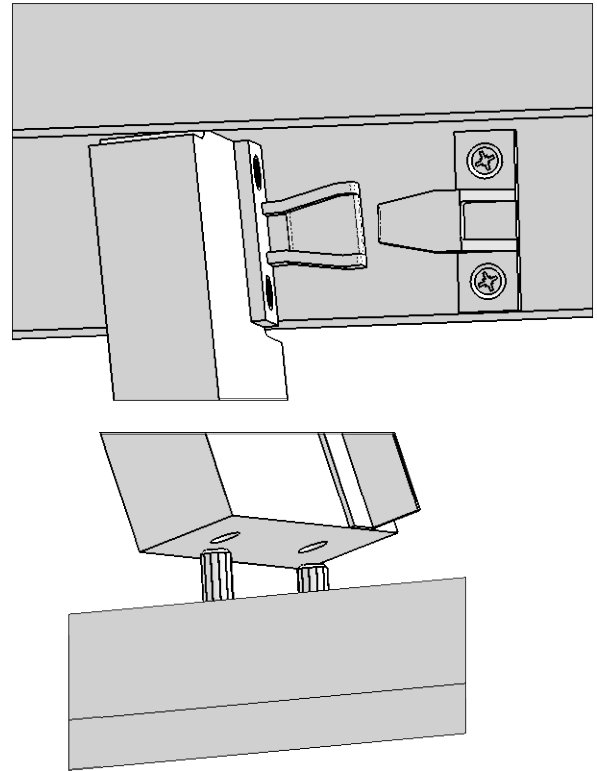
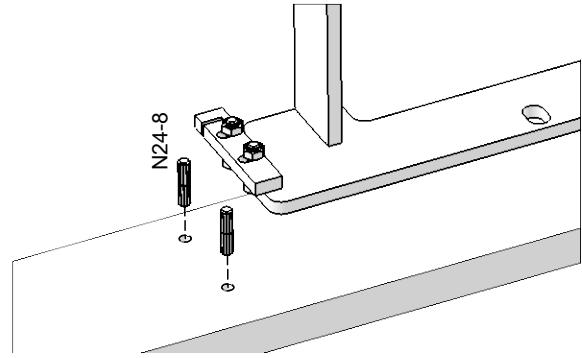
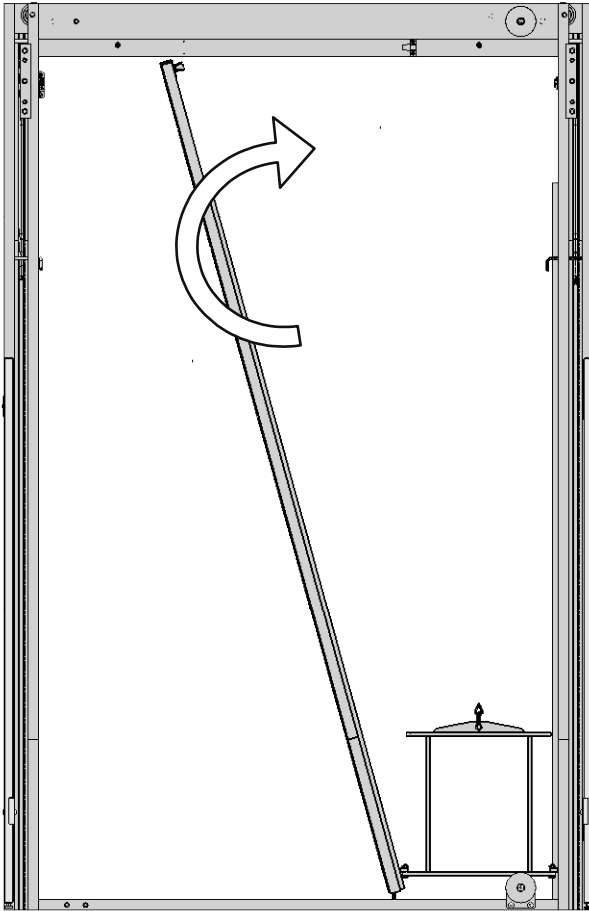



N24-8 x 2

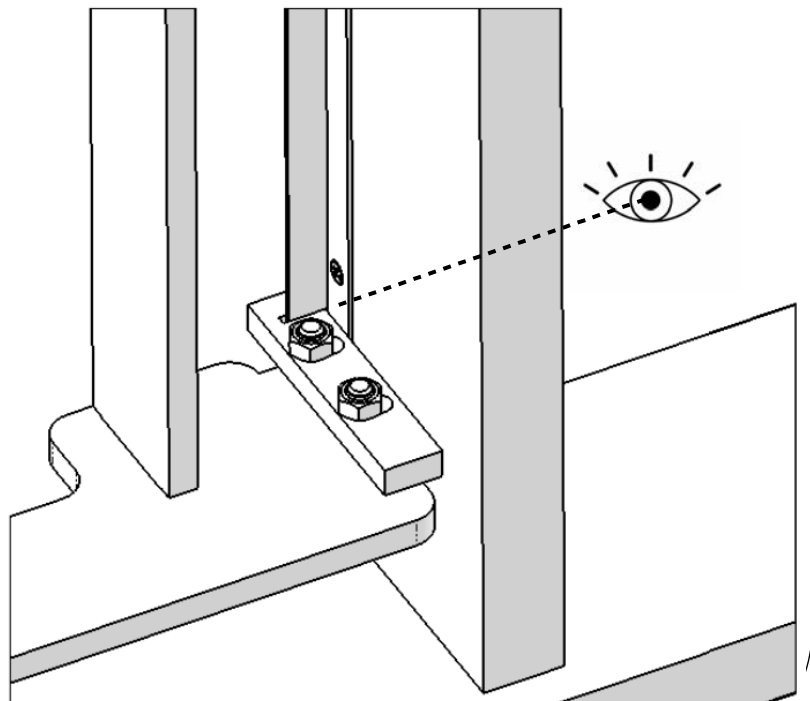
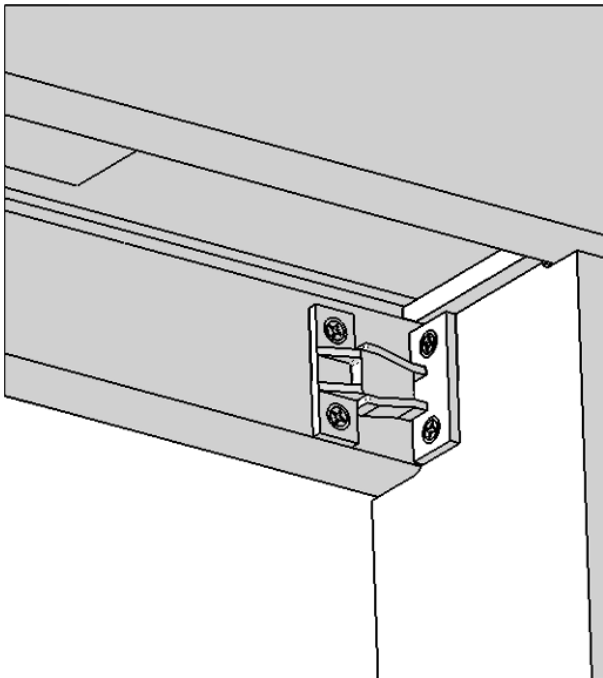
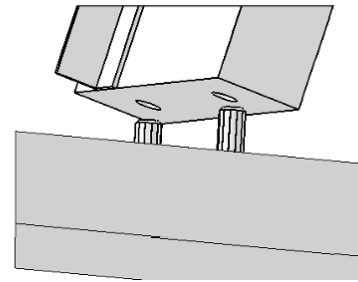
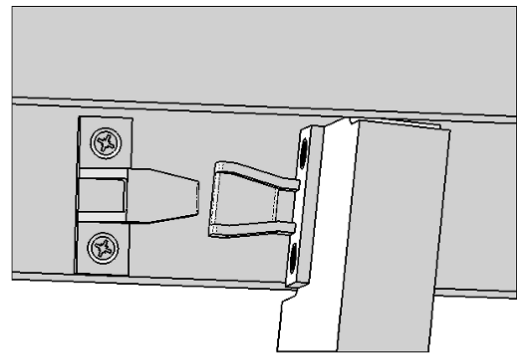
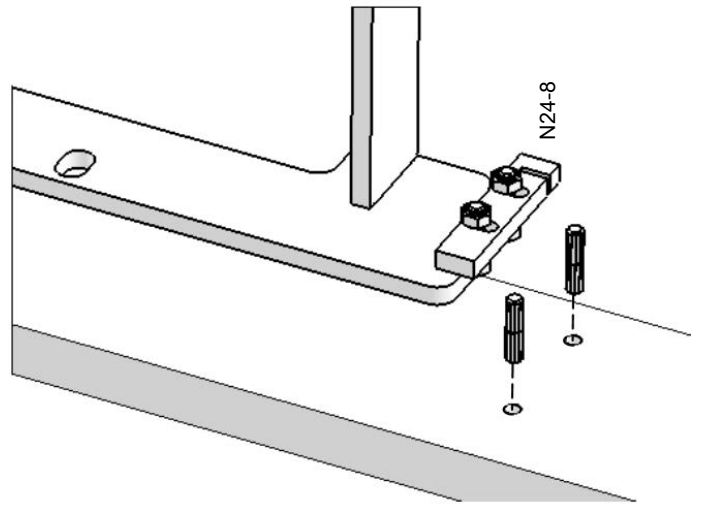
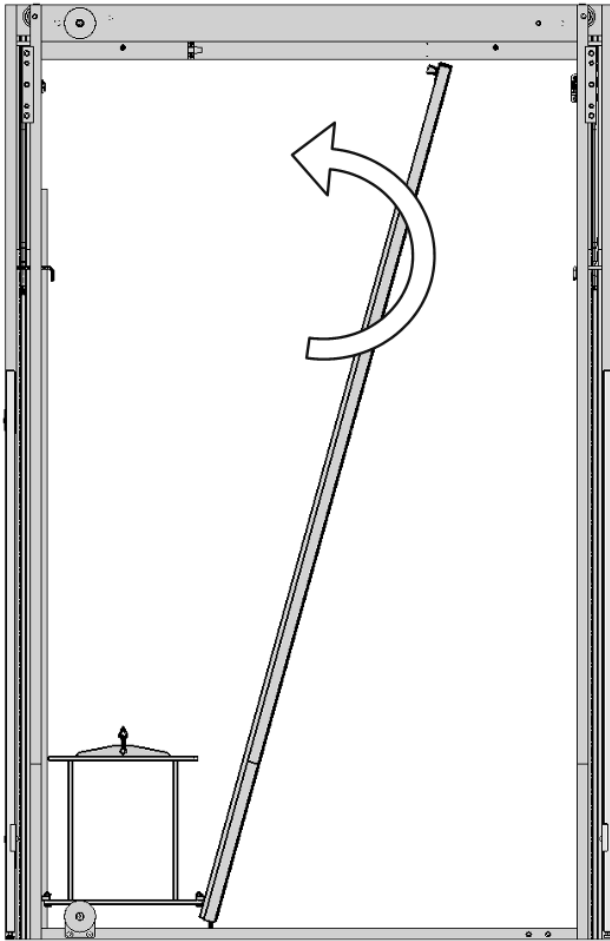

Bravo



The JUNO structure is up and running,
it's time to take a break before
fitting the bed frame



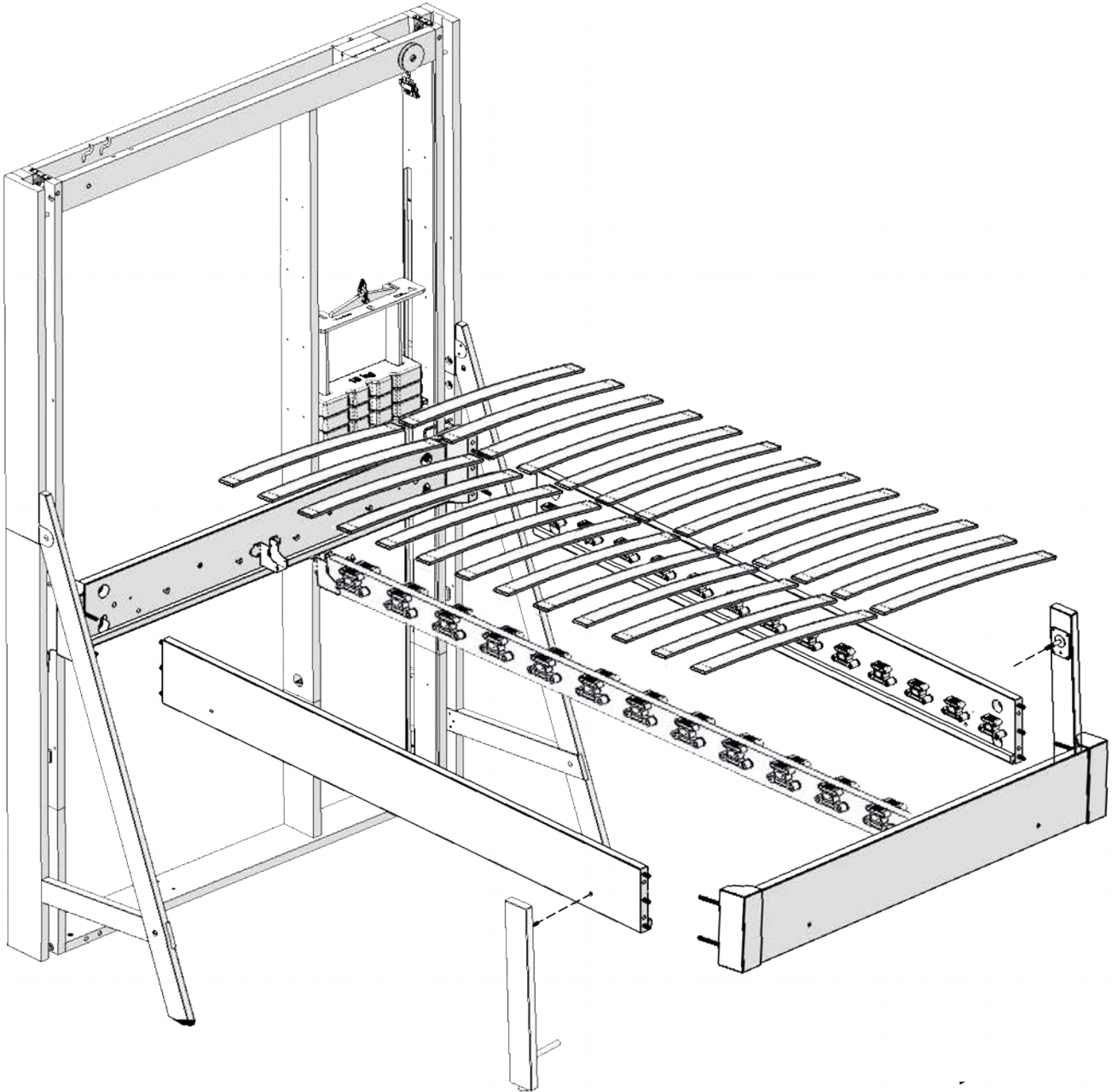

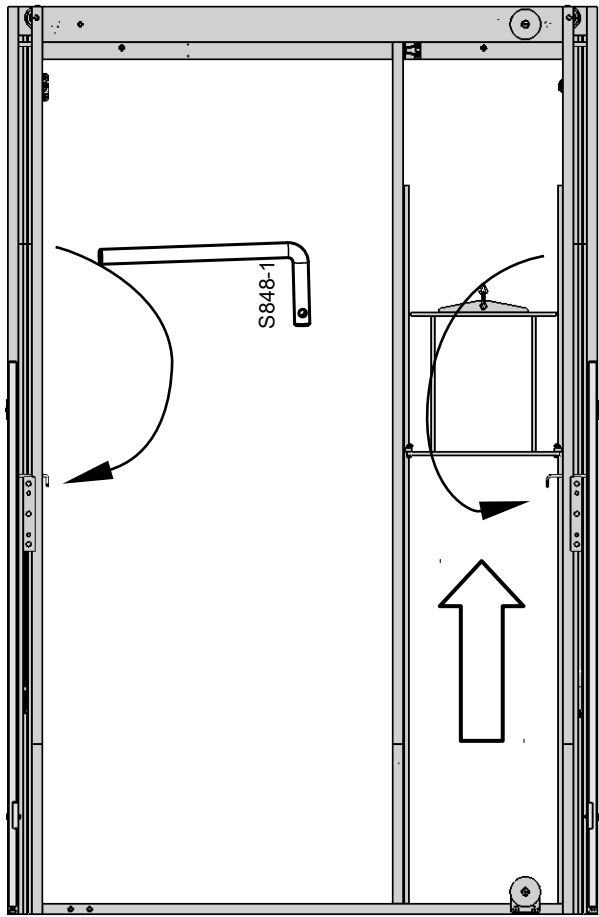

N555-1



Counterweight left : Follow the same steps

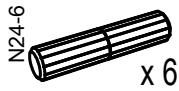
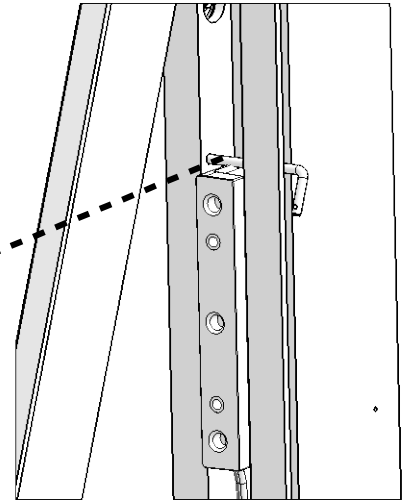

N25-30

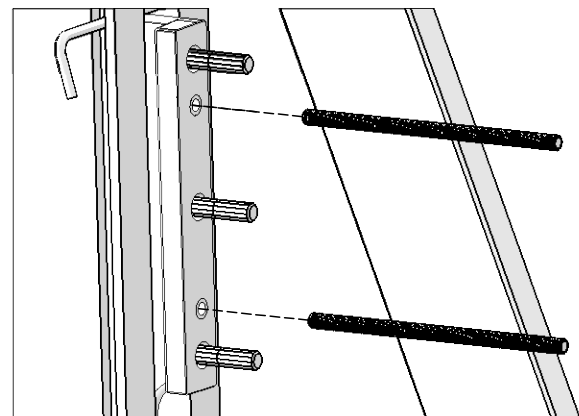
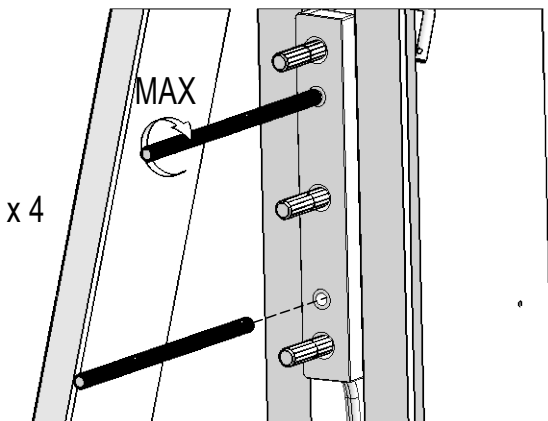
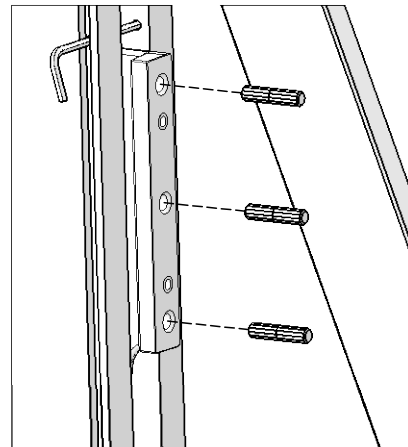
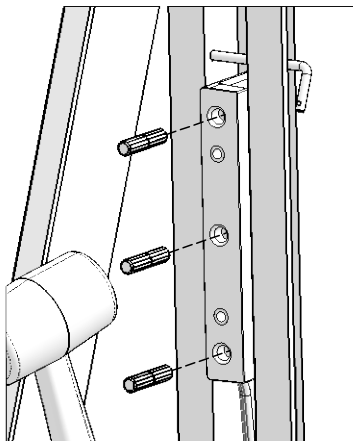

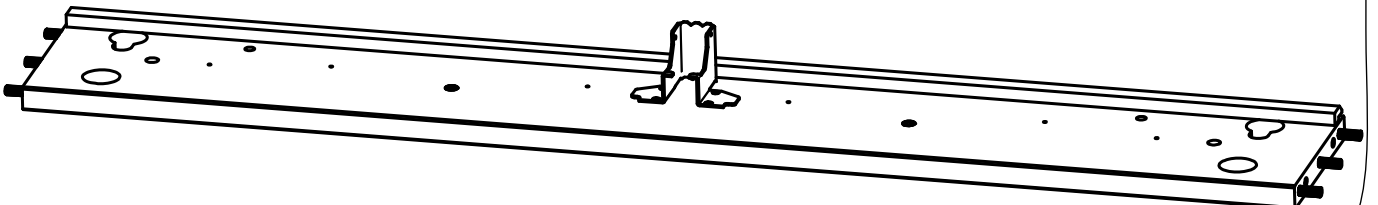
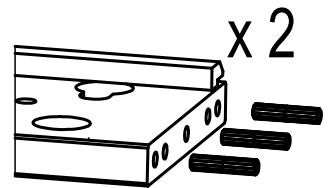
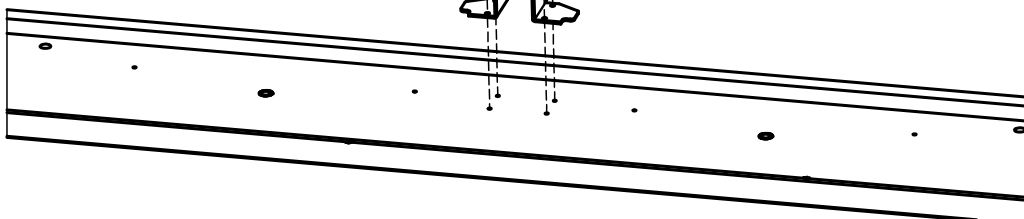
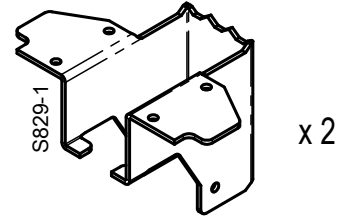
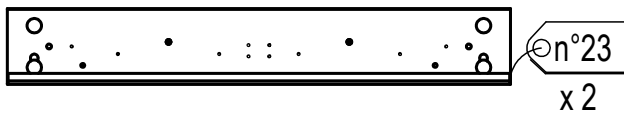
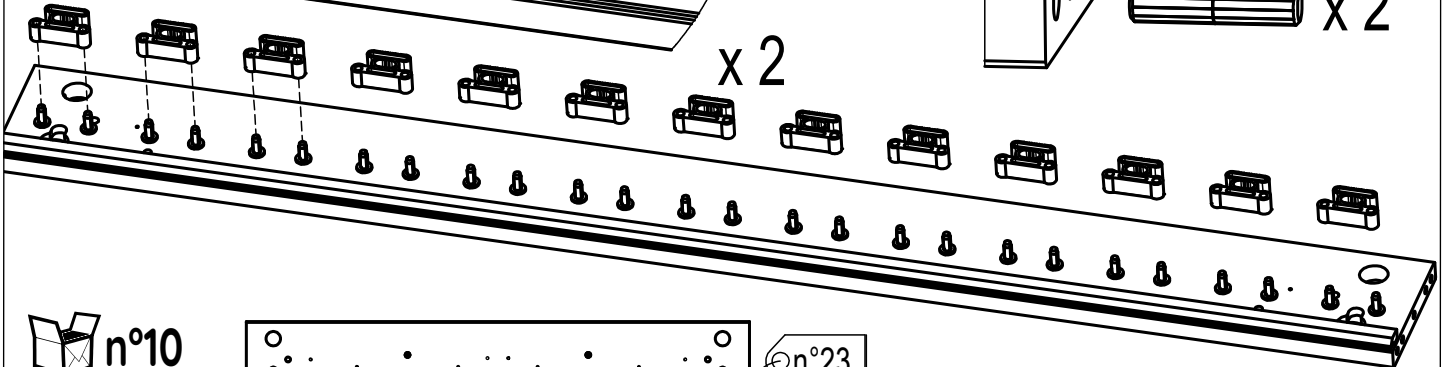
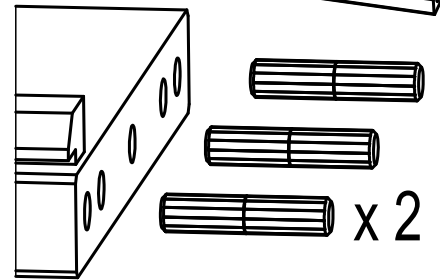
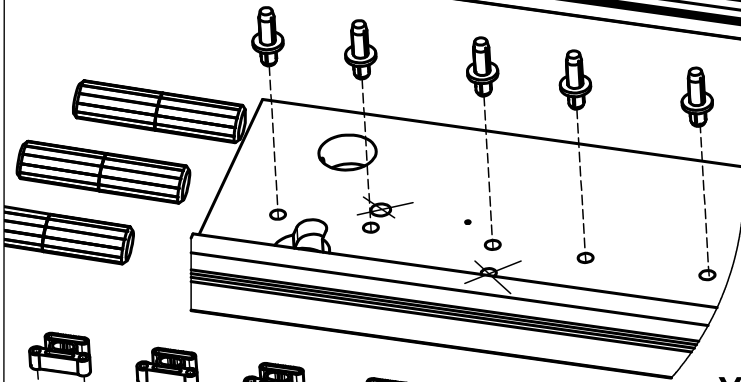
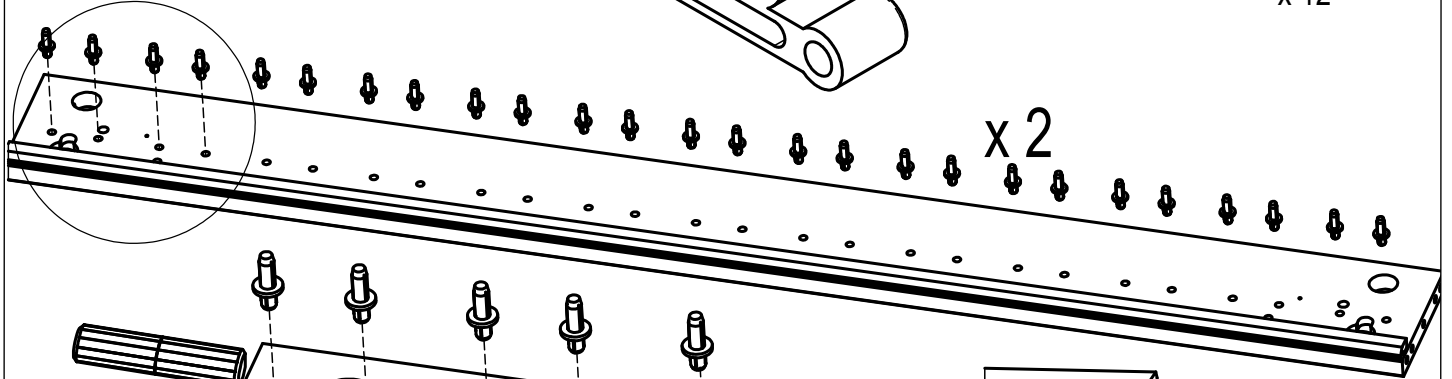
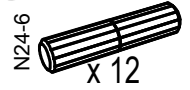
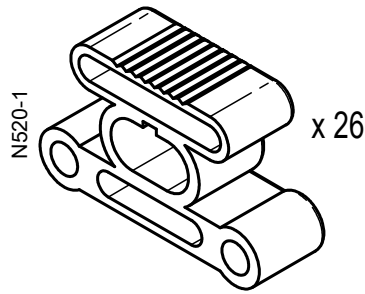
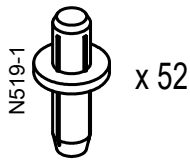
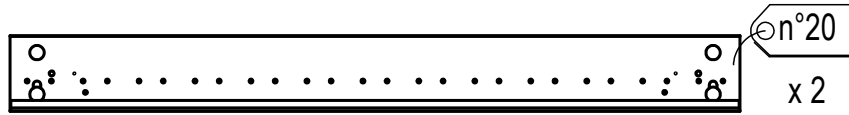



N25-25

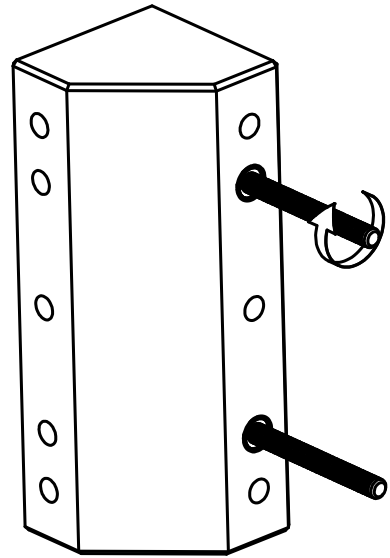
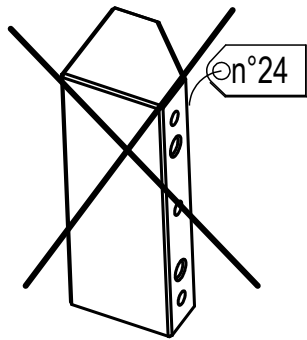
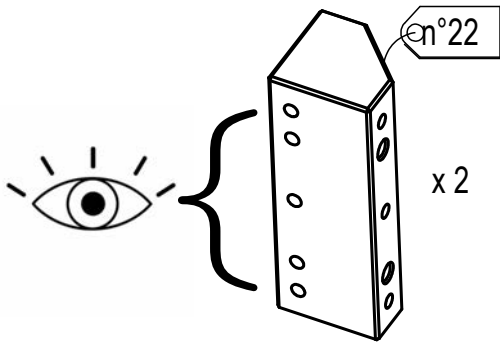

JUNO Vertikal

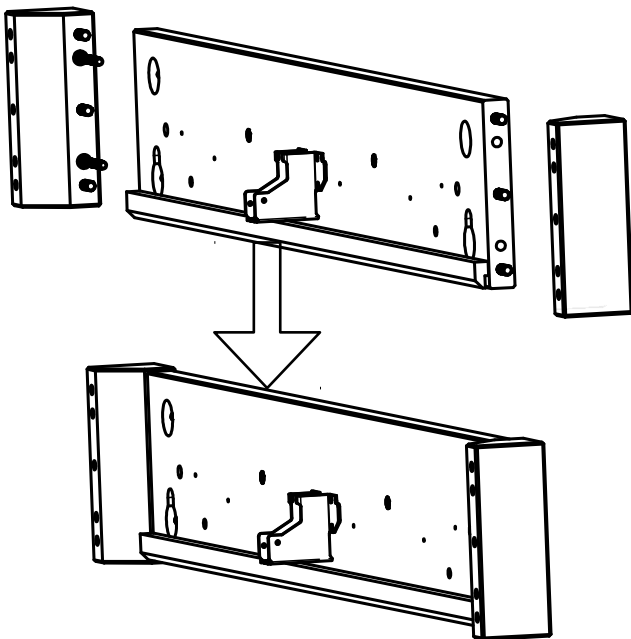

JUNO Horizon

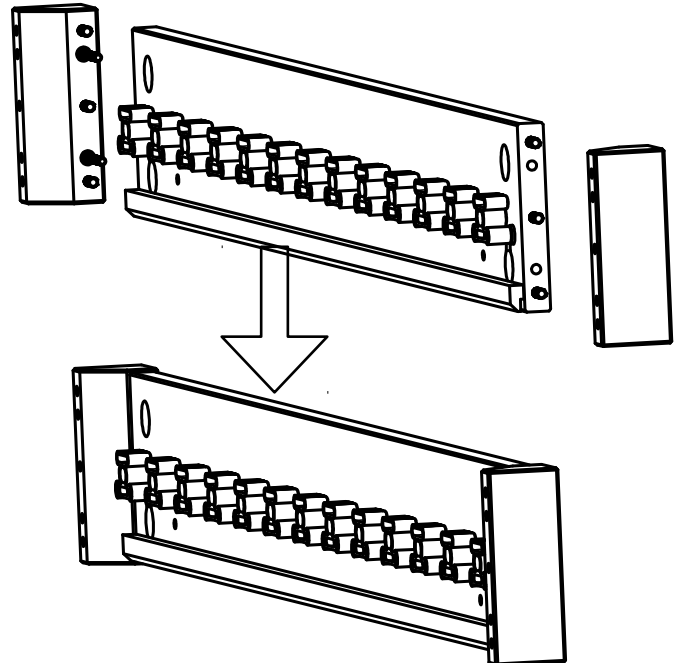

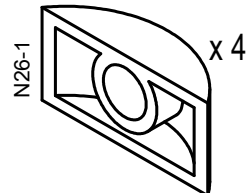
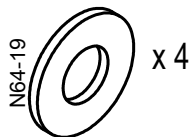
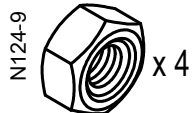

X 2

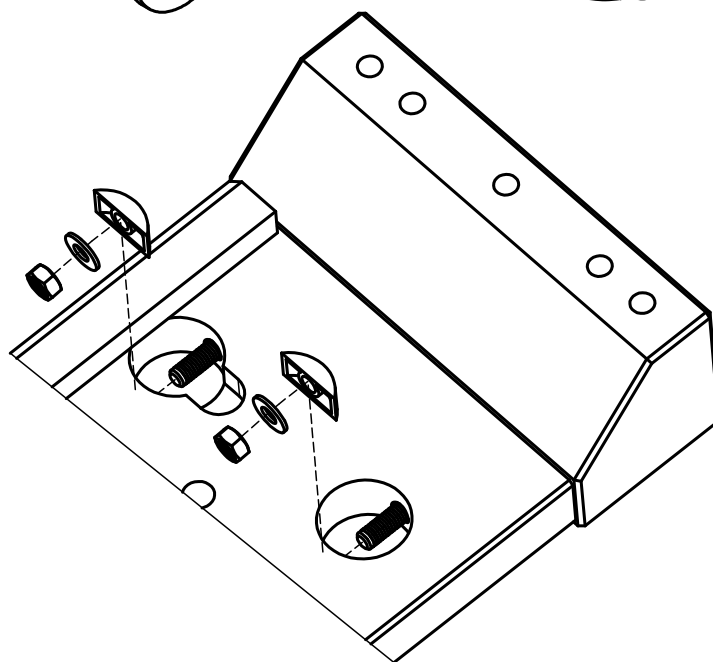

JUNO Vertikal

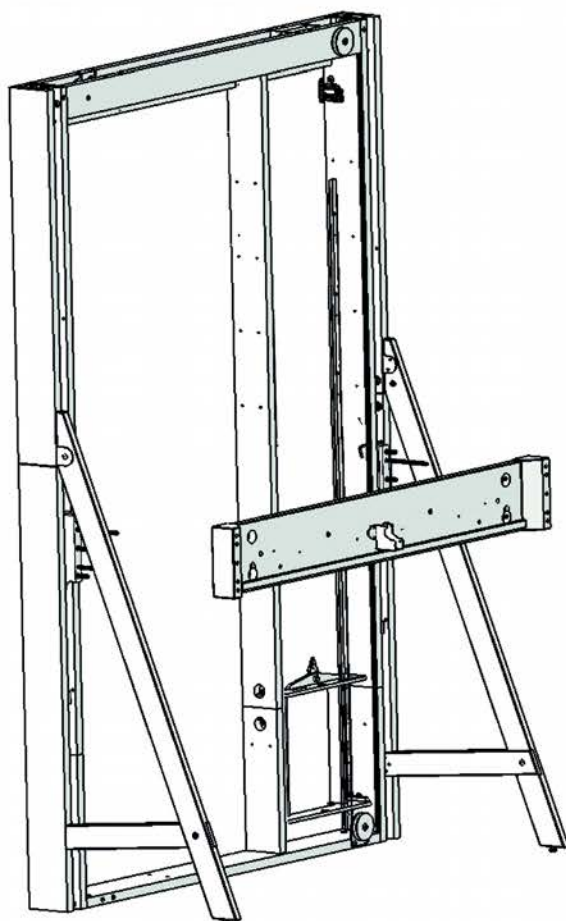

JUNO Horizon

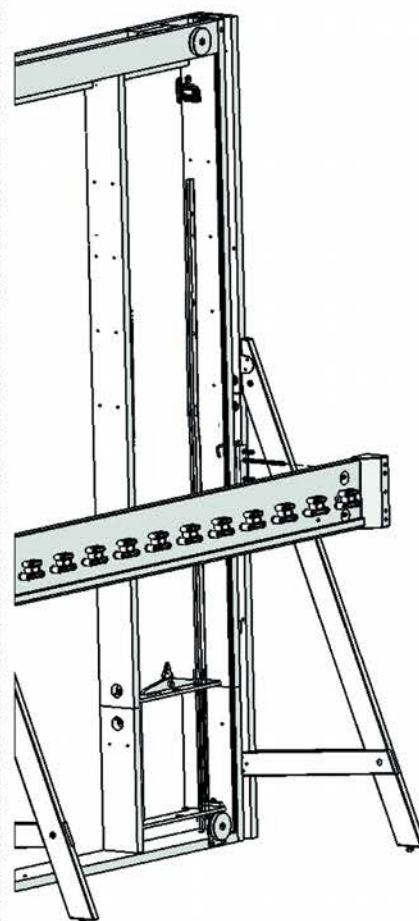

 n°9

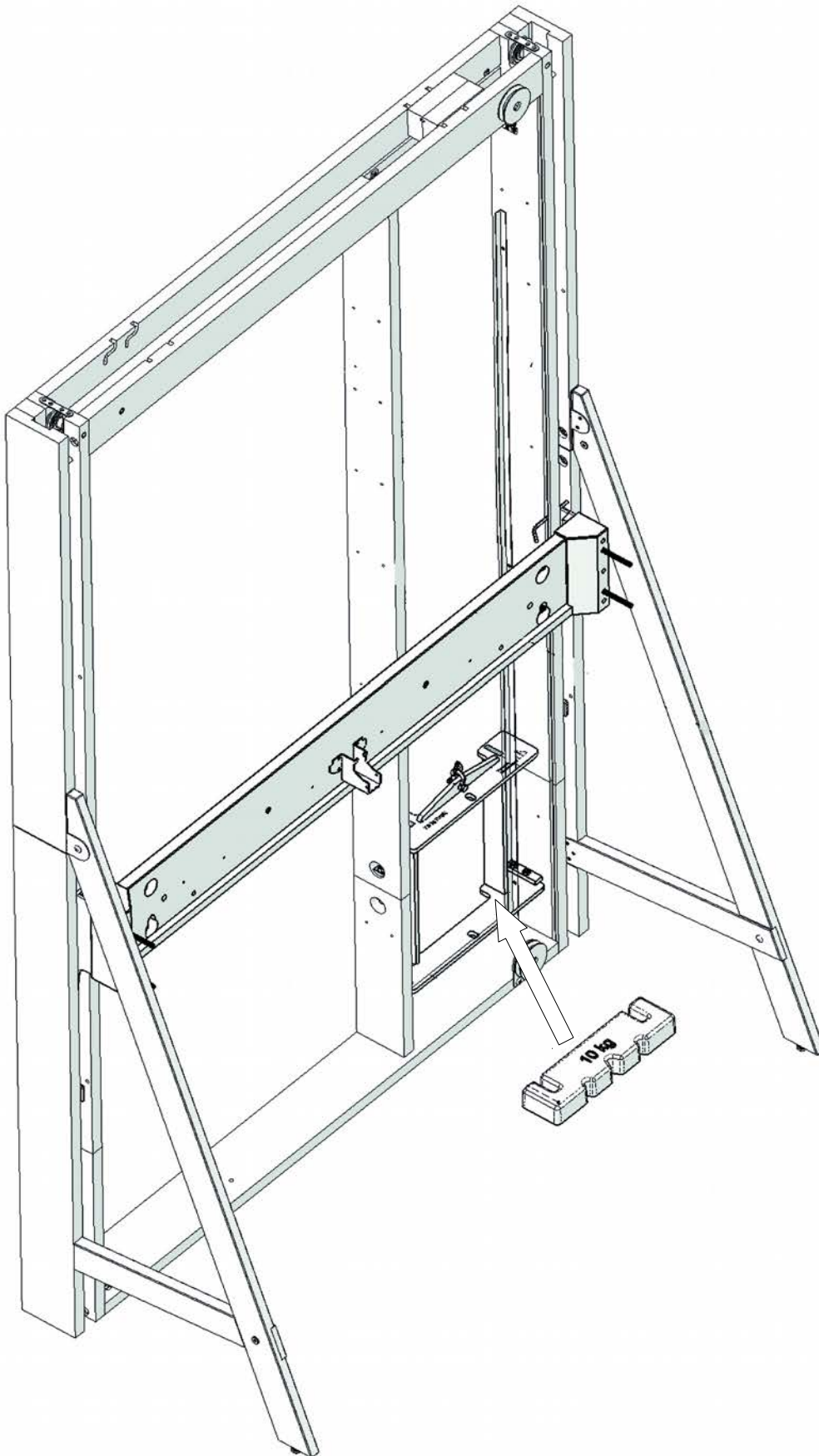



n°5

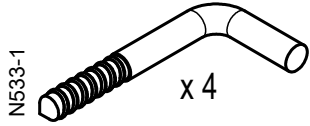

JUNO Vertikal

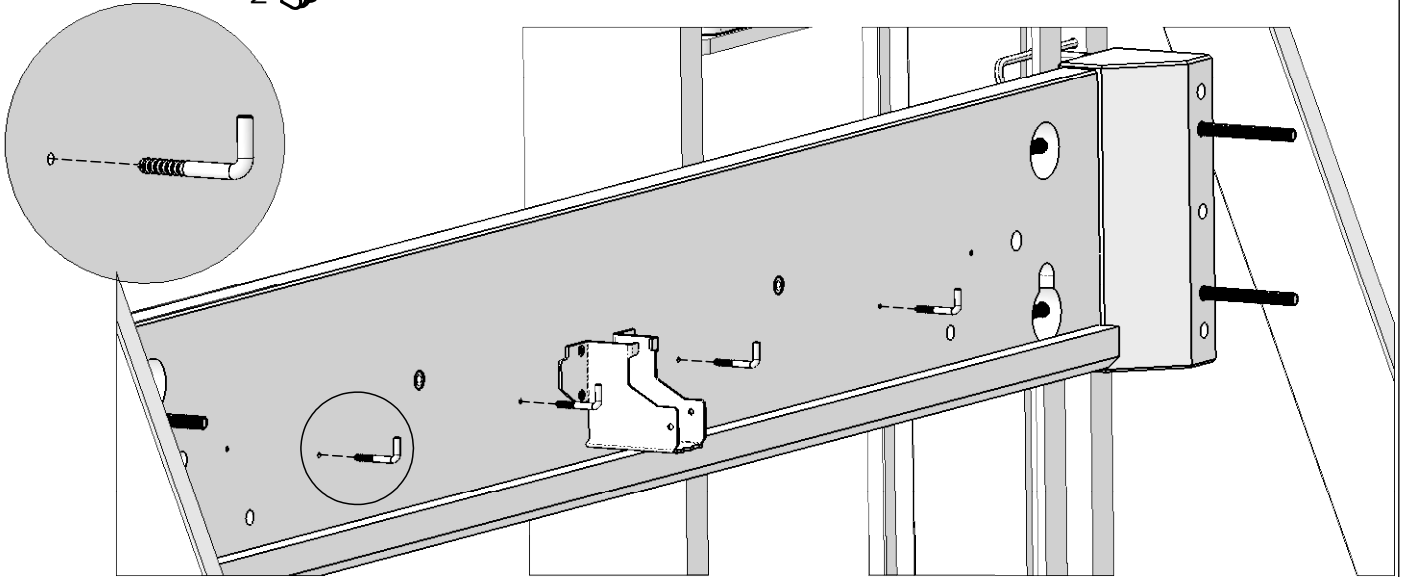

Vertikal & Horizon

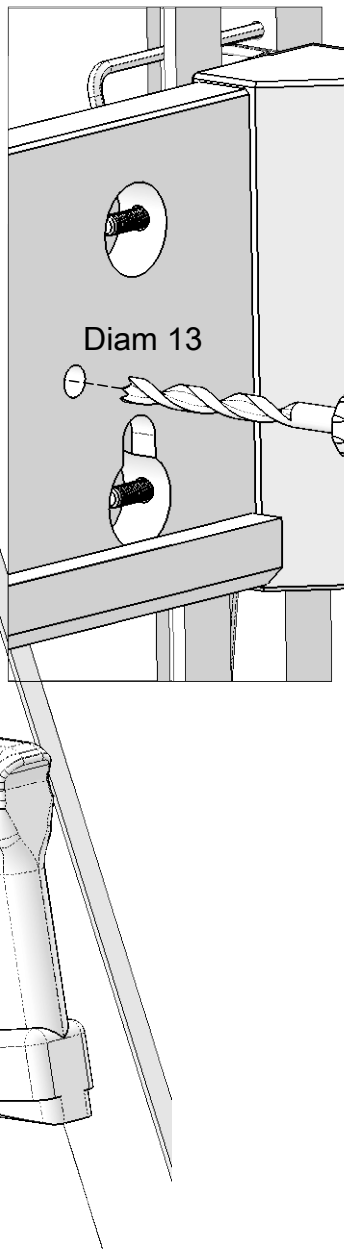

Vertikal & Horizon

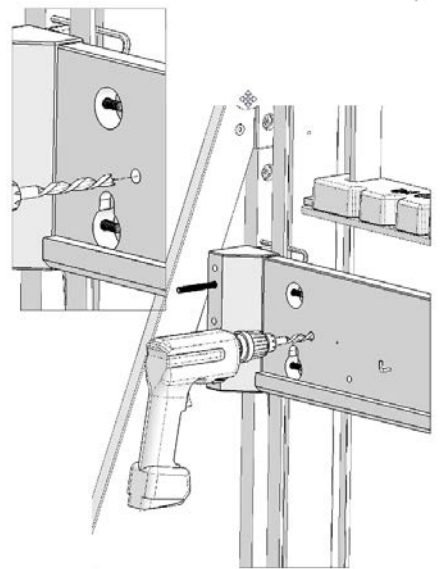

 n°2 S844-1  x1

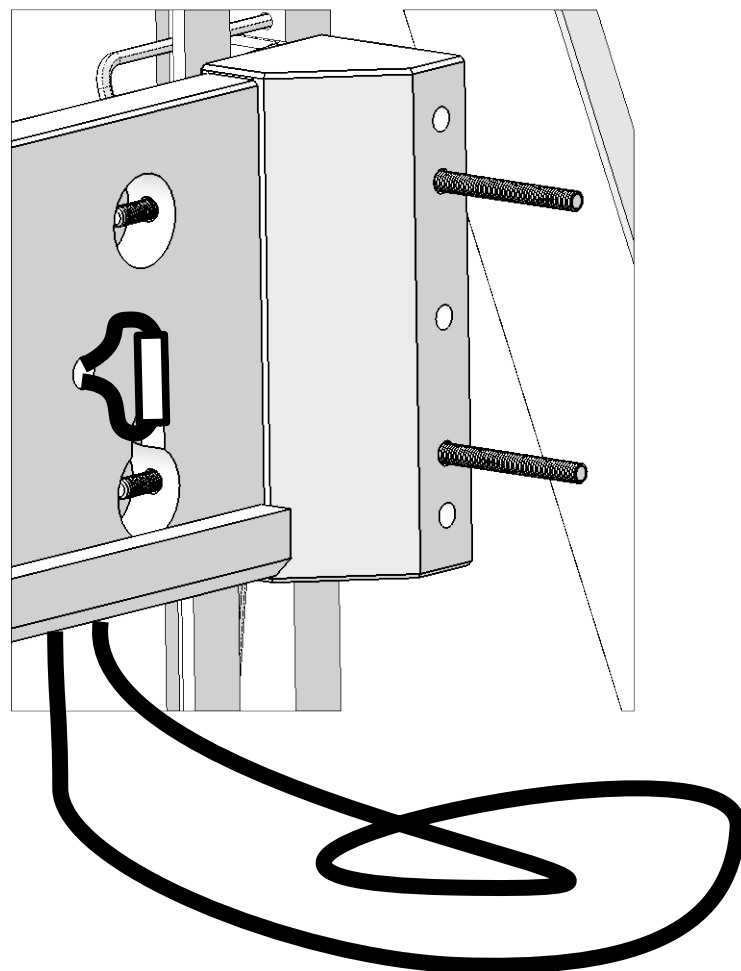
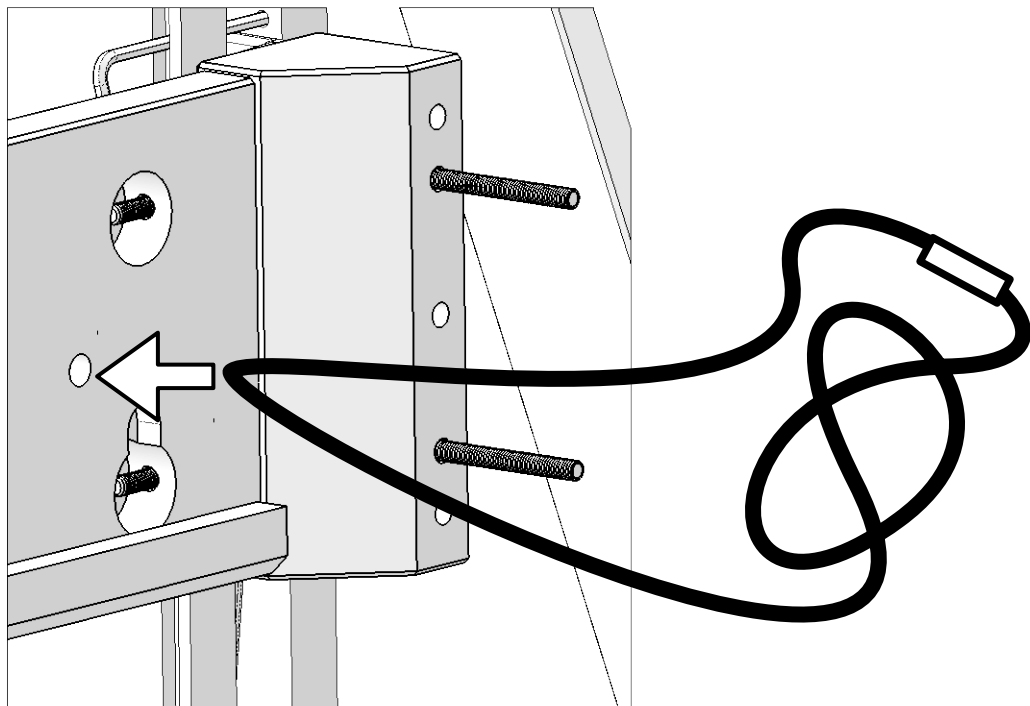

☐ n°9

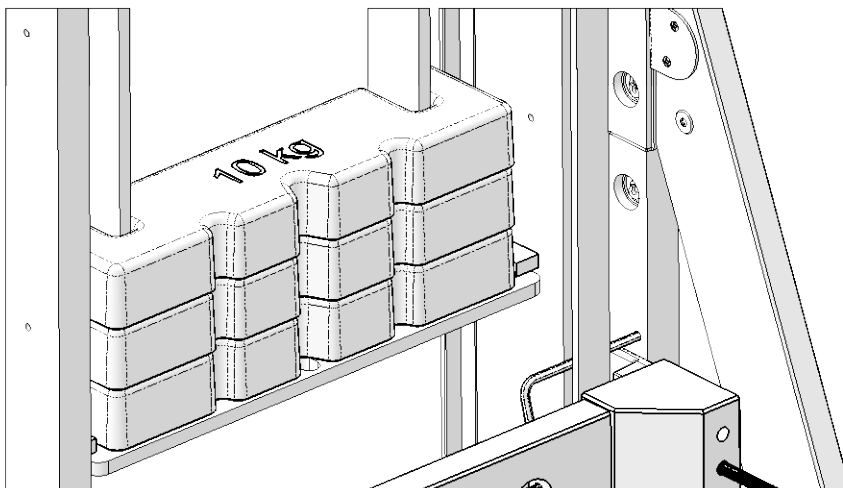
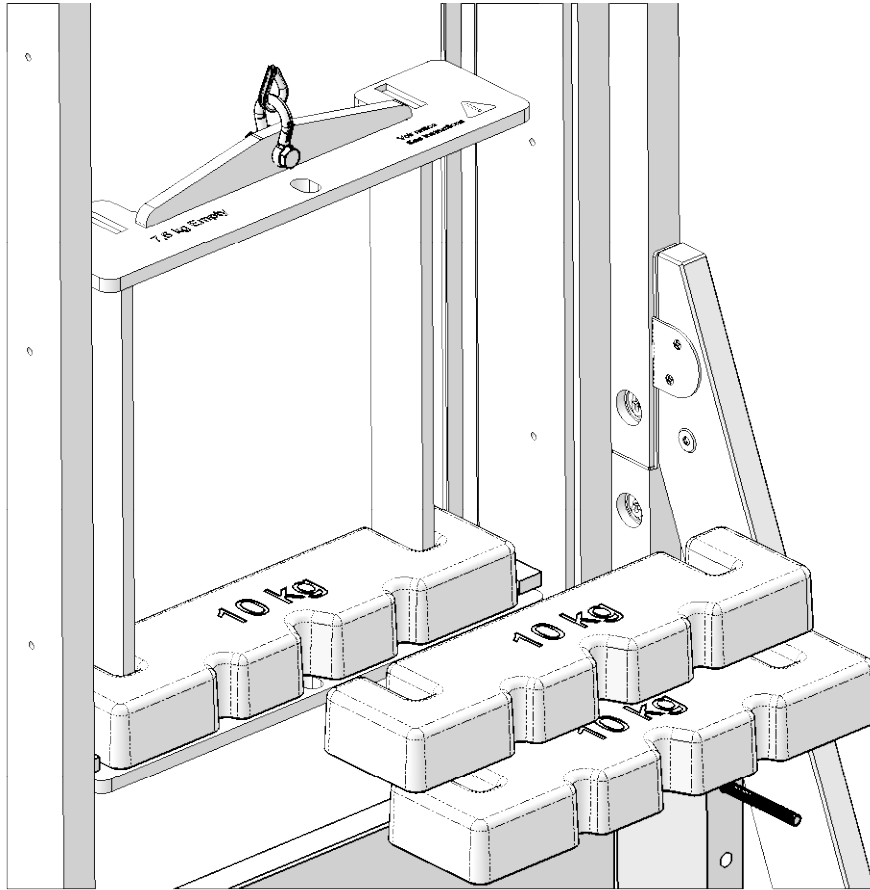
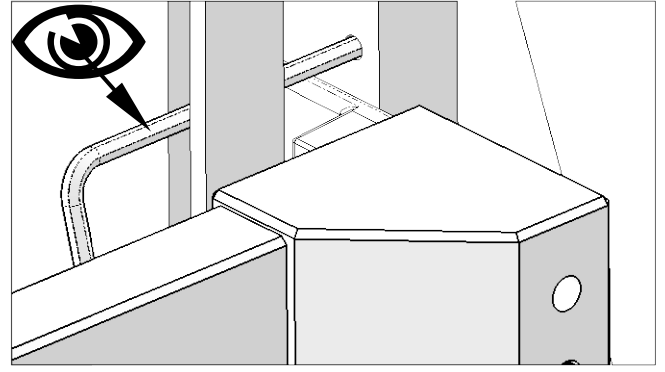
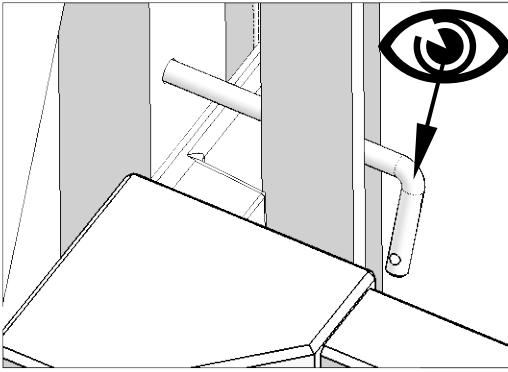

 n°4

JUNO Vertikal

 x2

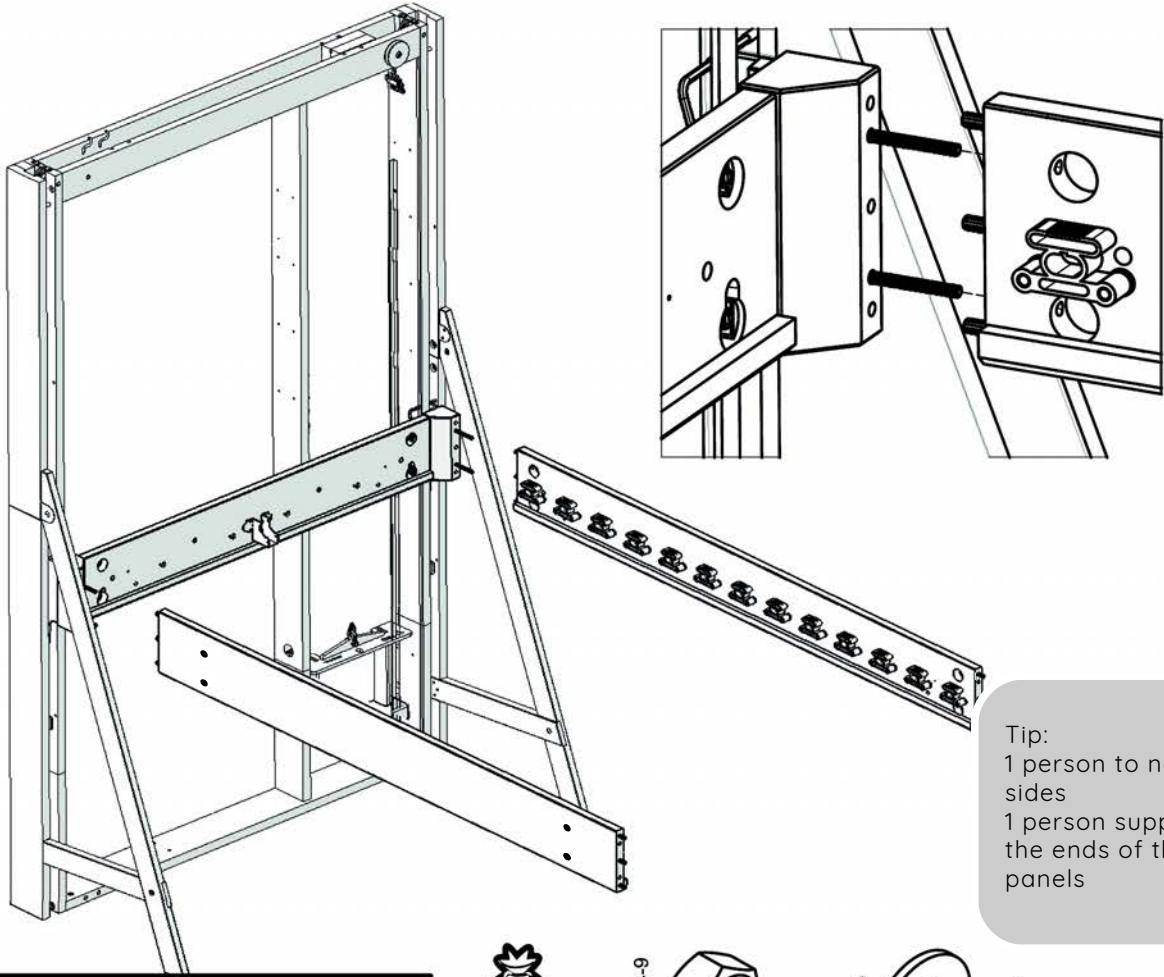

Tip:
1 person to nest the sides
1 person supports the ends of the panels

JUNO Horizon

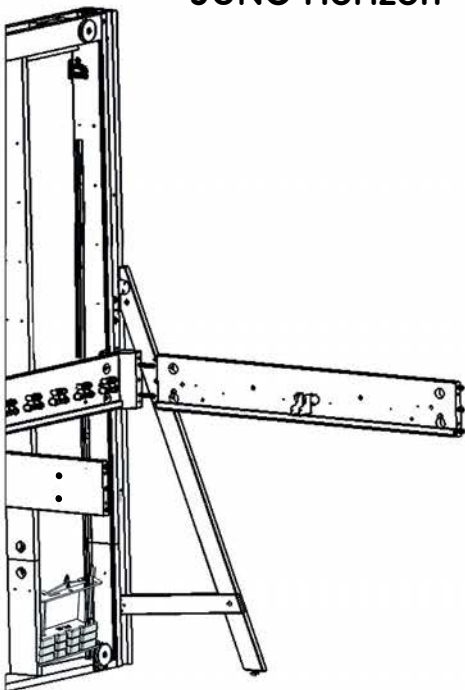

 n°5 N124-9  x 4 N64-19  x 4

 n°1 N26-1  x 4

x 2

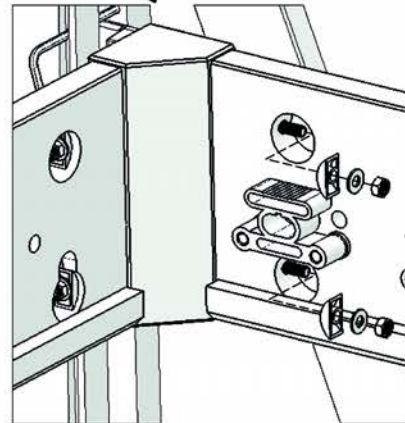

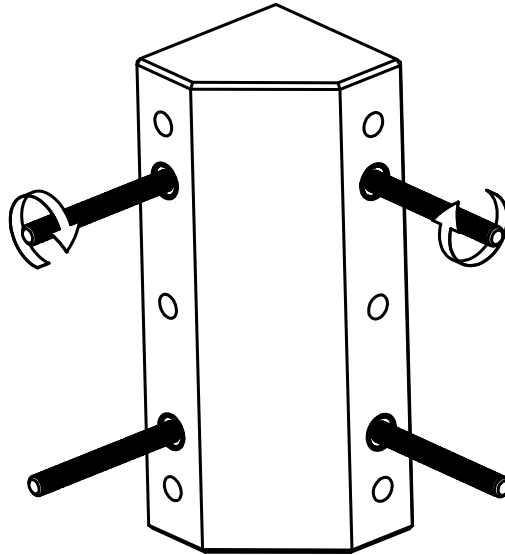
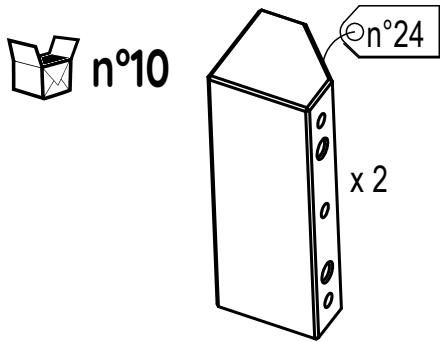

JUNO Vertikal

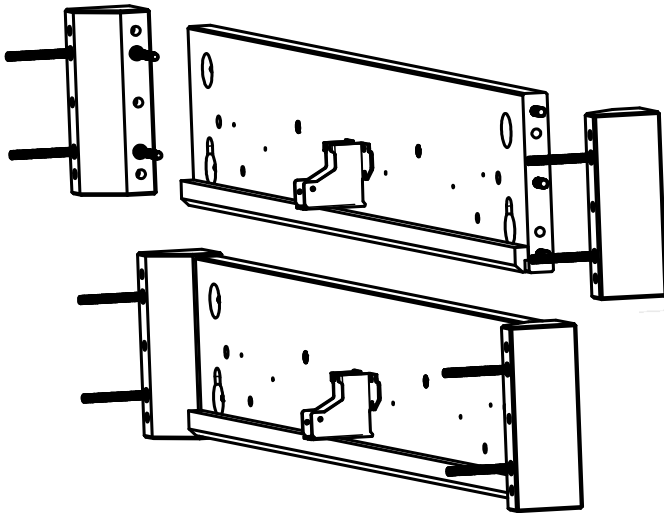

JUNO Horizon

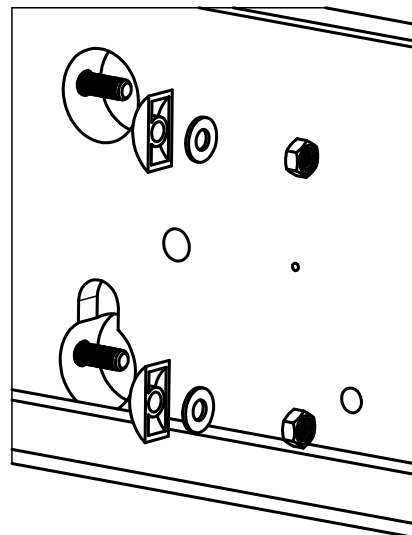
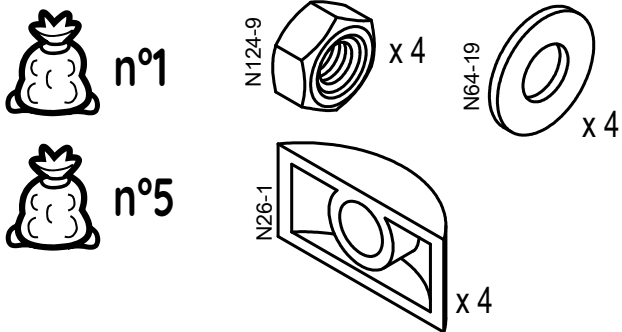
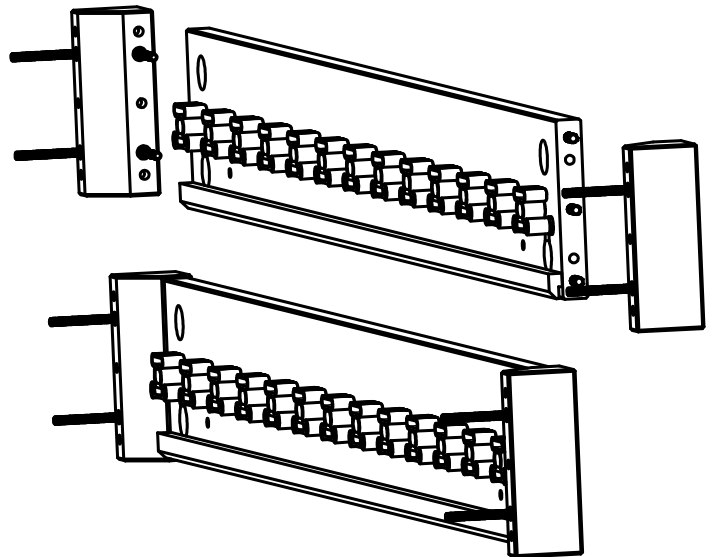

x 2

JUNO Vertikal

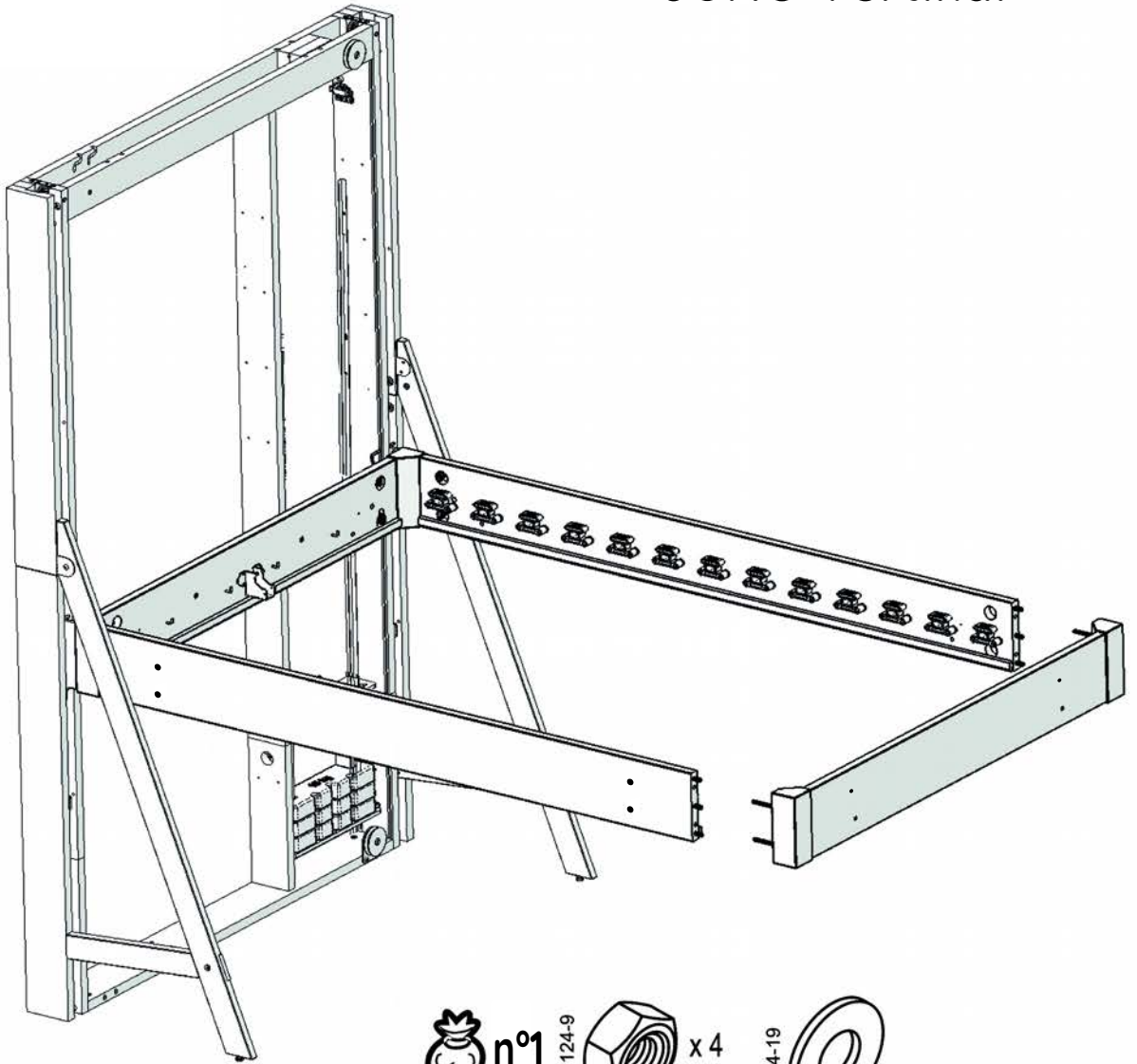

JUNO Horizon

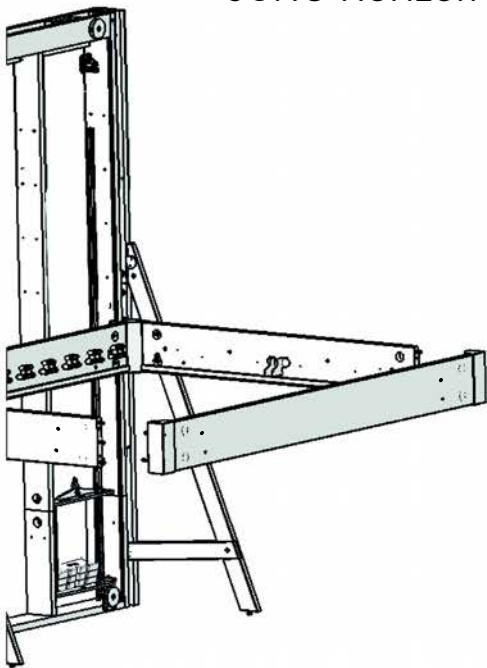

n°1

N124-9



x 4

N64-19



x 4



n°5

N26-1



x 4

x 2

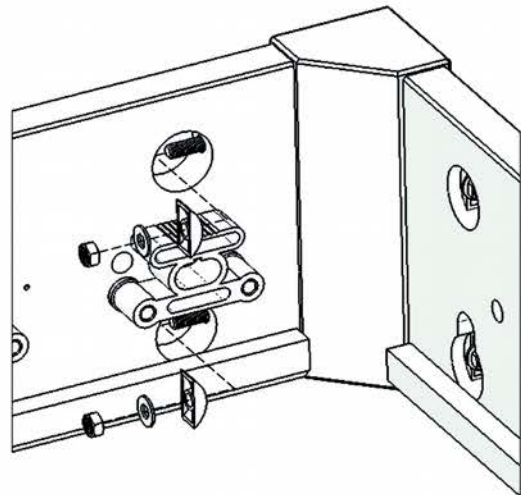

 n°1

N519-1 x 52

N520-1 x 26

n°21

1

2

4

n°1

N31-21

x 4

3

JUNO Vertikal

x 2

JUNO
Horizon

JUNO Horizon



n°5

N533-1

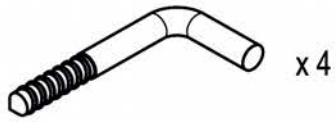

x4

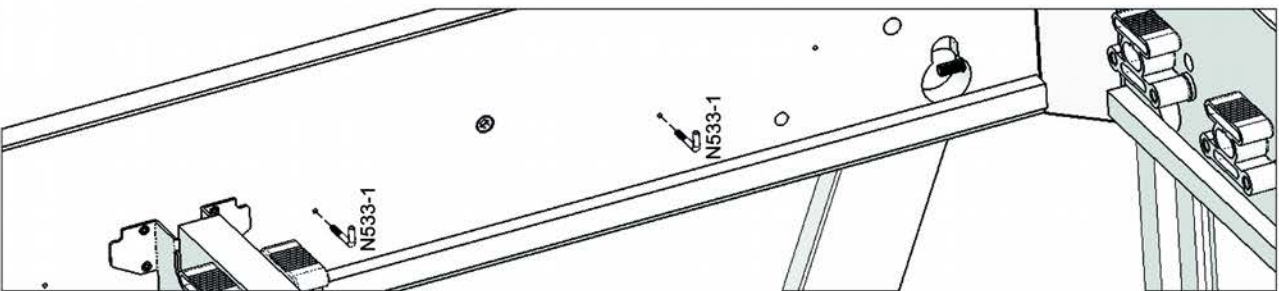
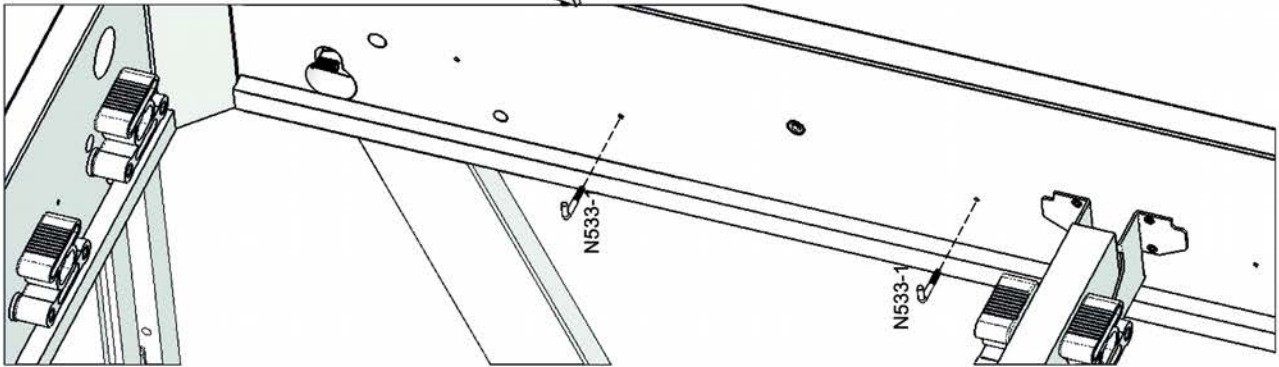
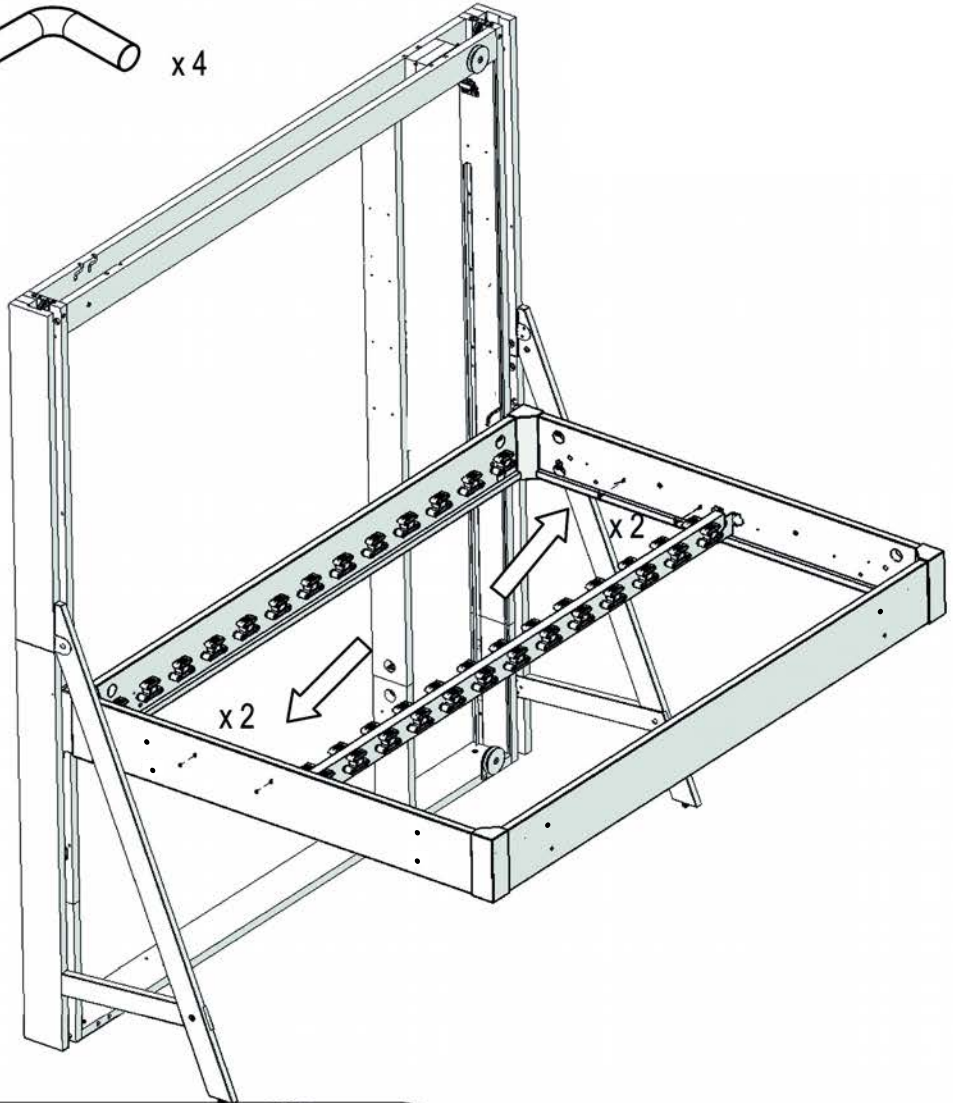

 n°1  n°5

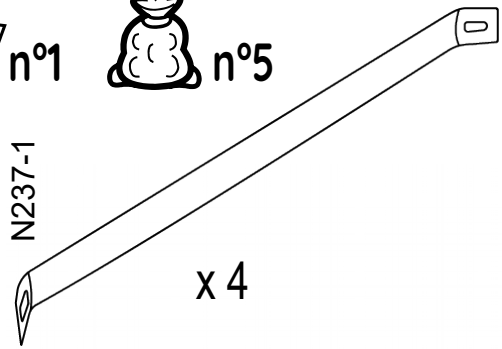

N561-1  x 8

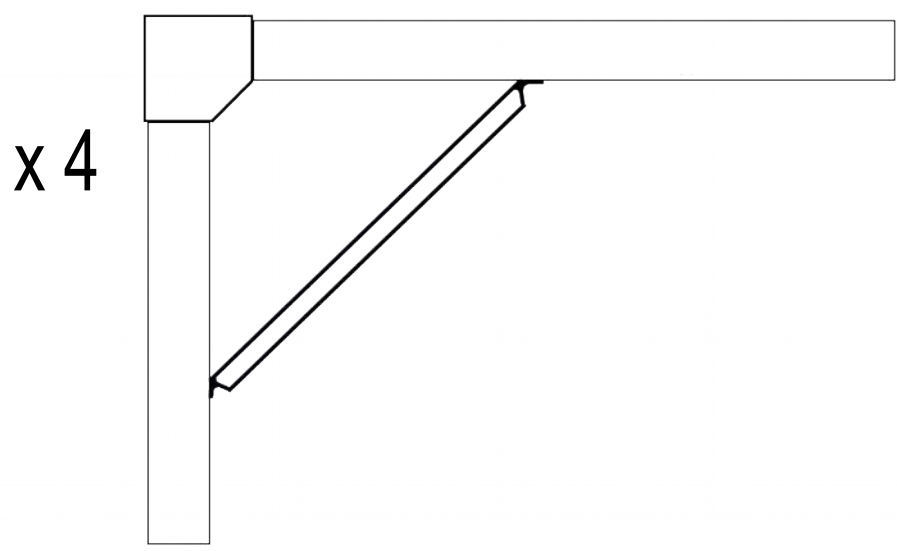
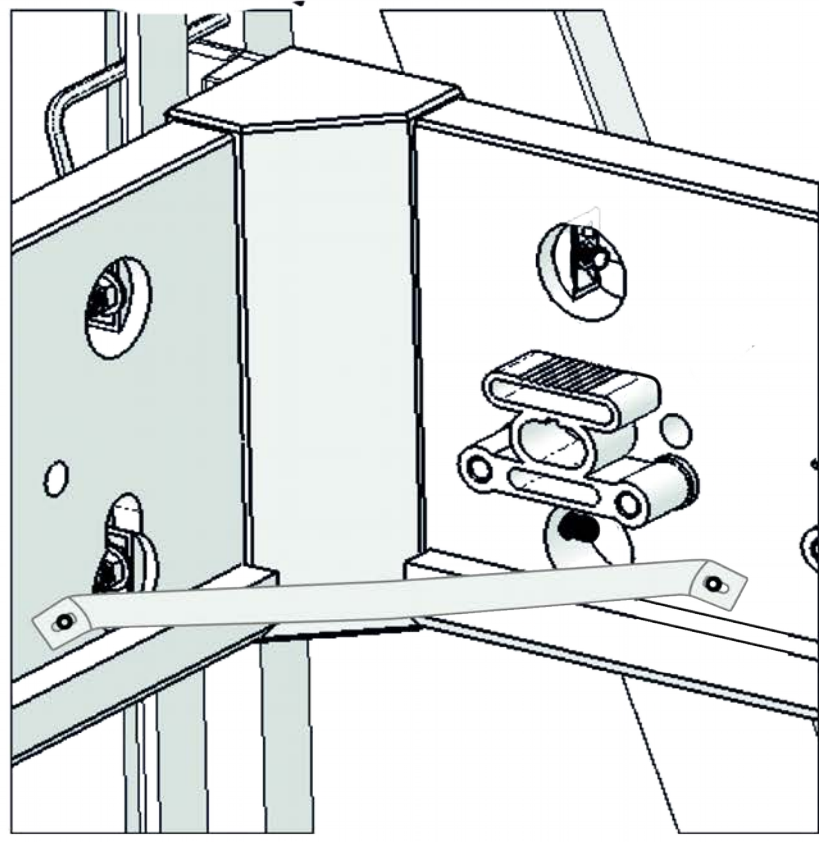

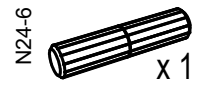
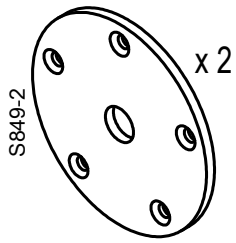

JUNO Horizon

JUNO Vertikal

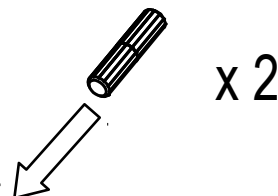
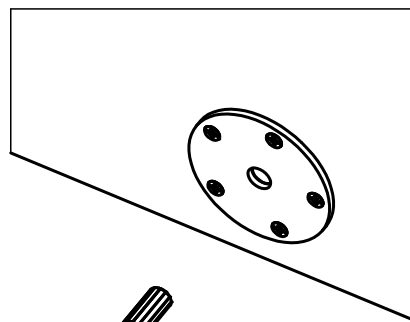
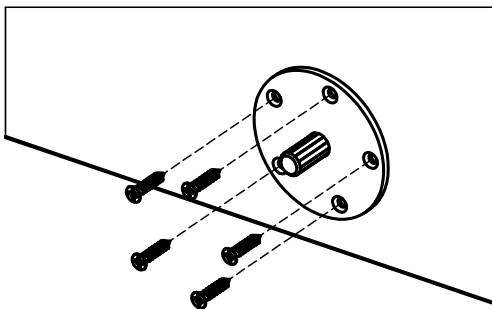
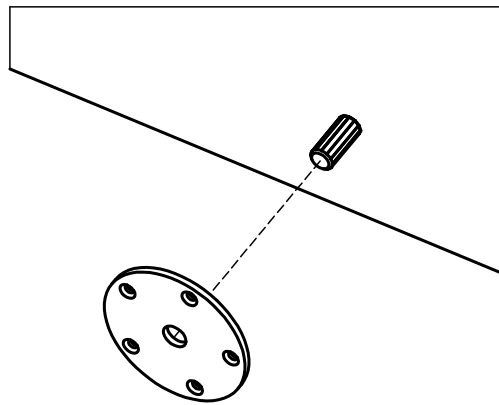
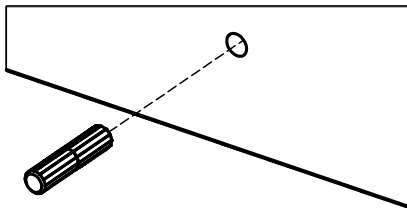
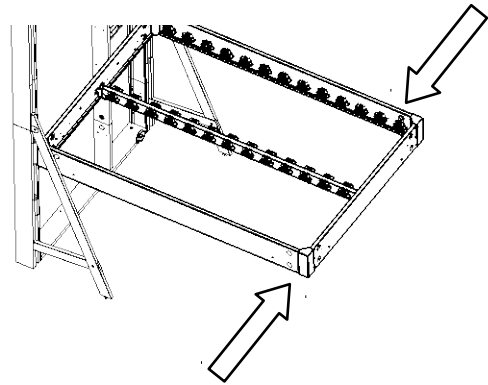
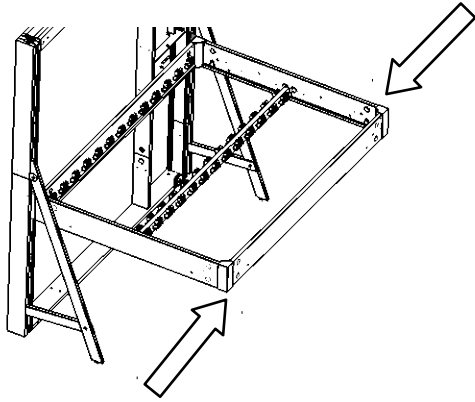

 n°6

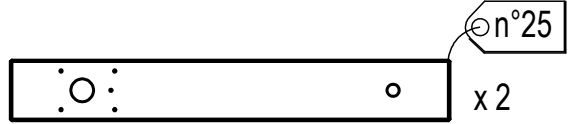

 n°6

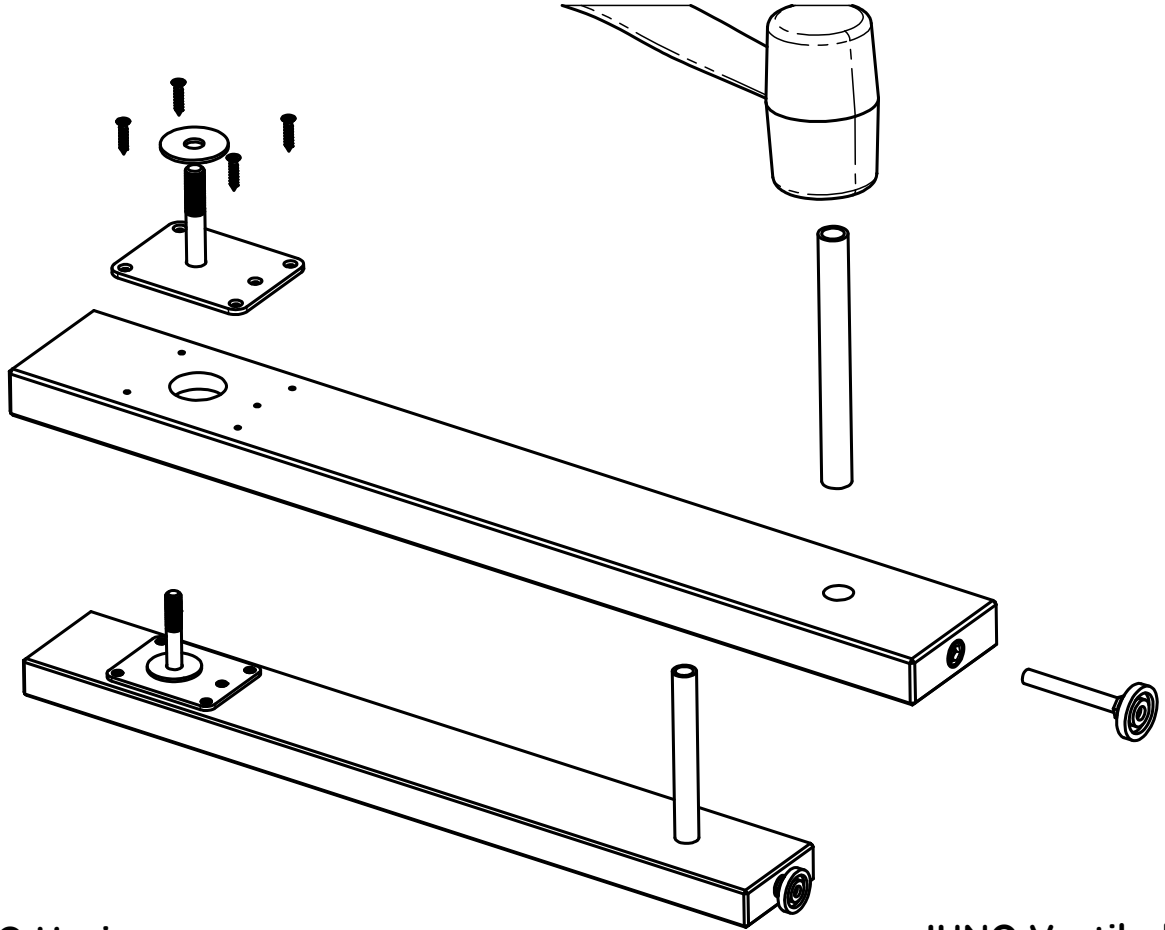
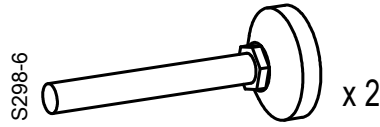
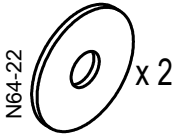
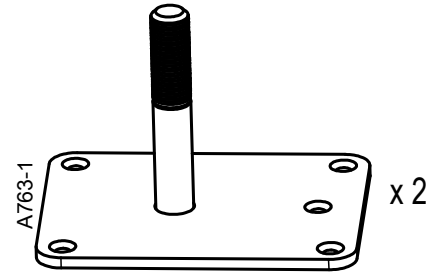
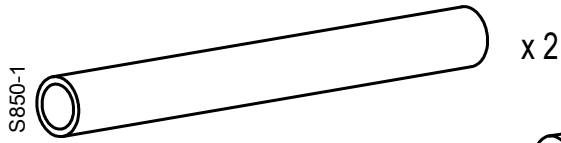

JUNO Horizon

JUNO Vertikal

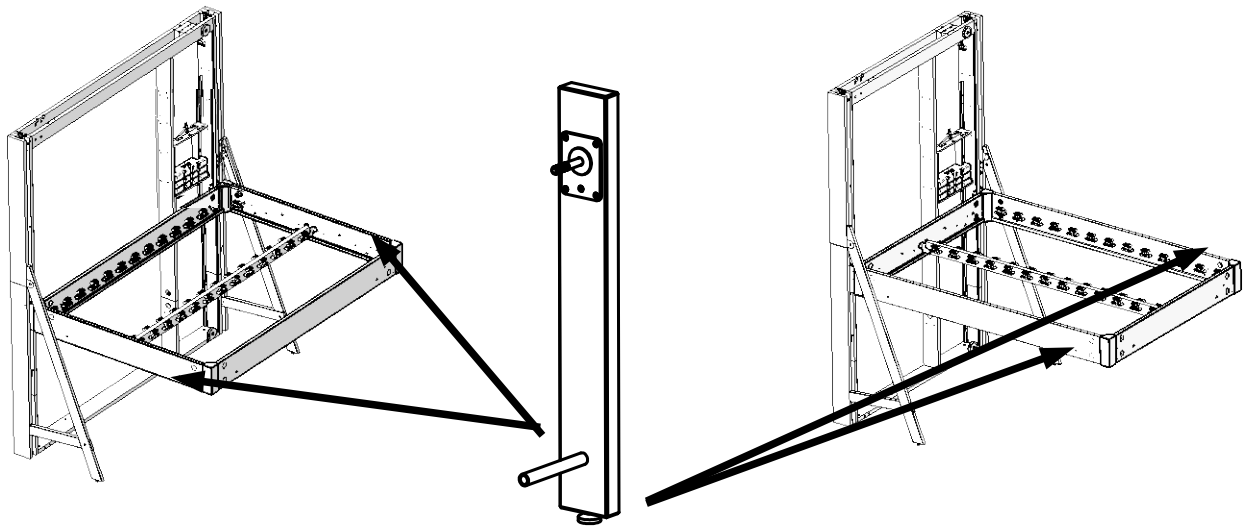

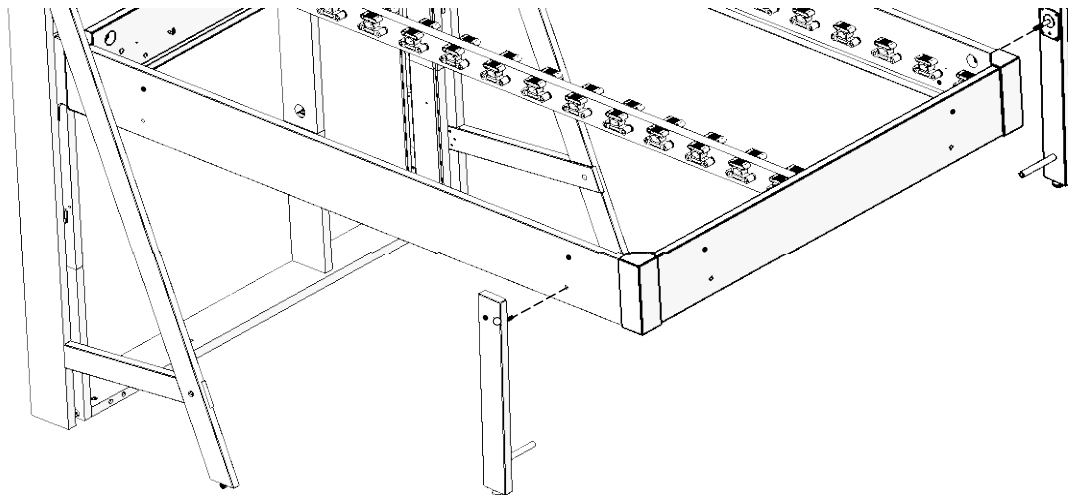

n°6

N124-14



x 2

N188-7



x 2

N64-22



x 2

x 2

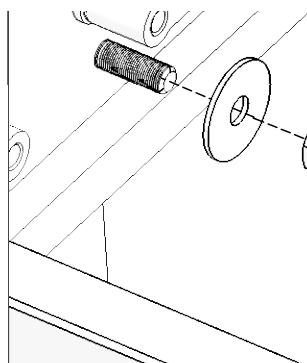

N188-7

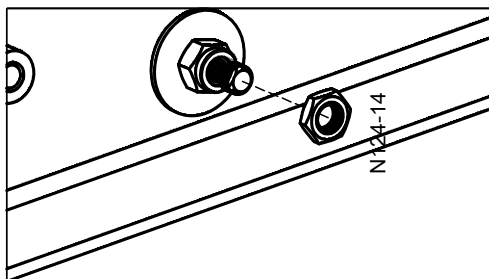
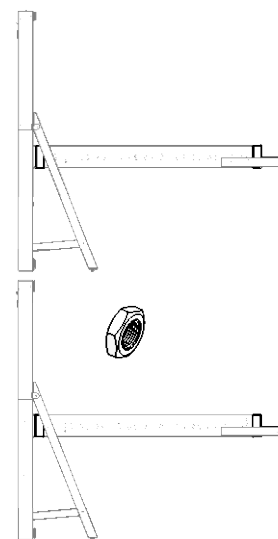
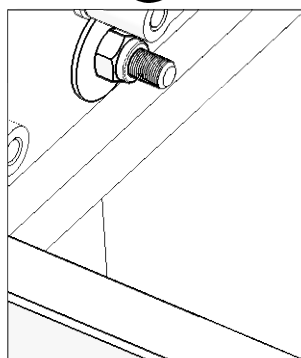

N124-14

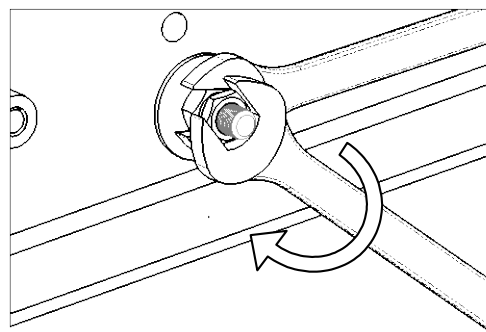

 n°9

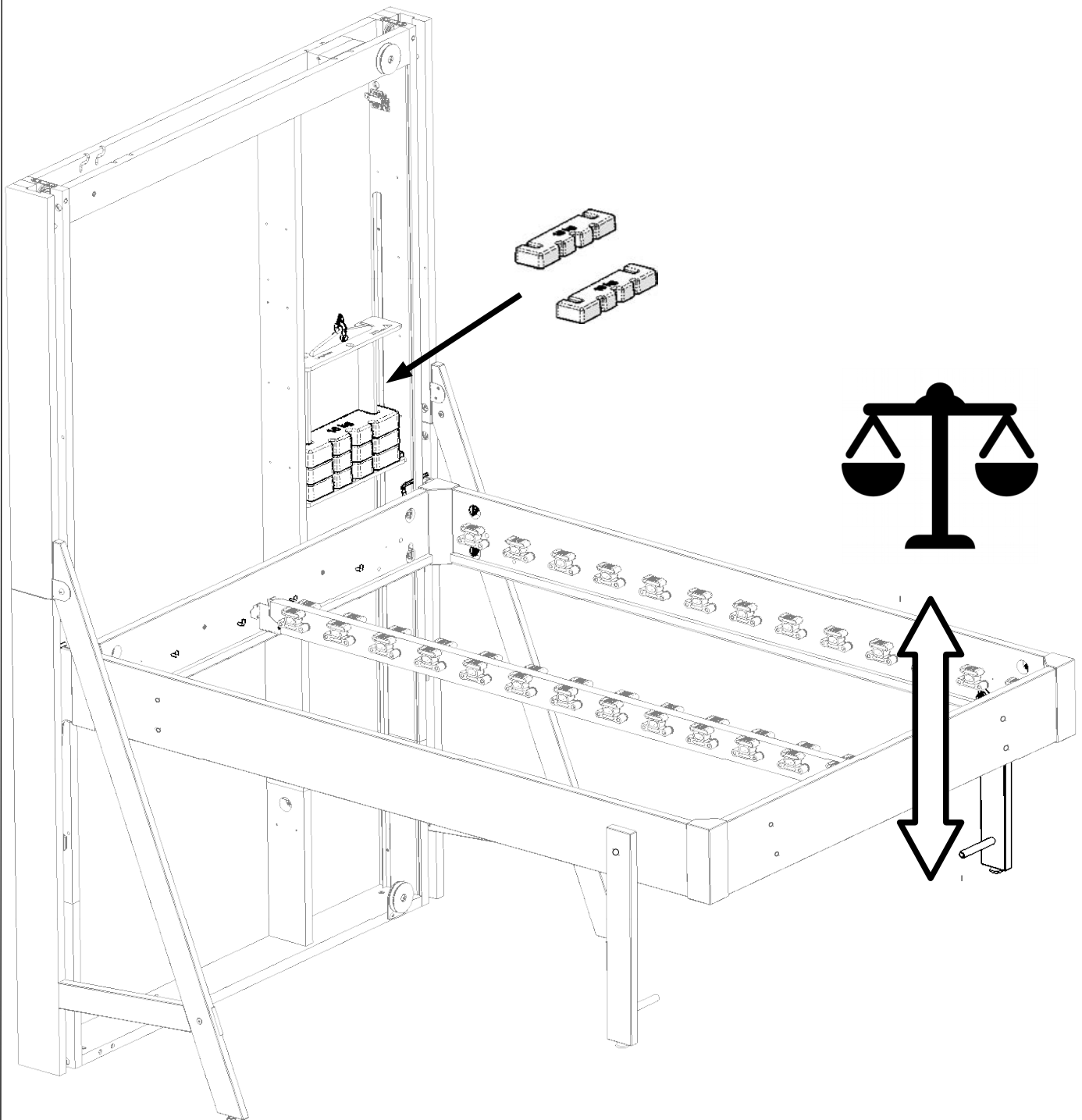

Balance your bed:
Remove the pins from the frame Add
two 10 kg weights
Lower your bed with the legs unfolded



n°10

N23-13 ou 12

x 26

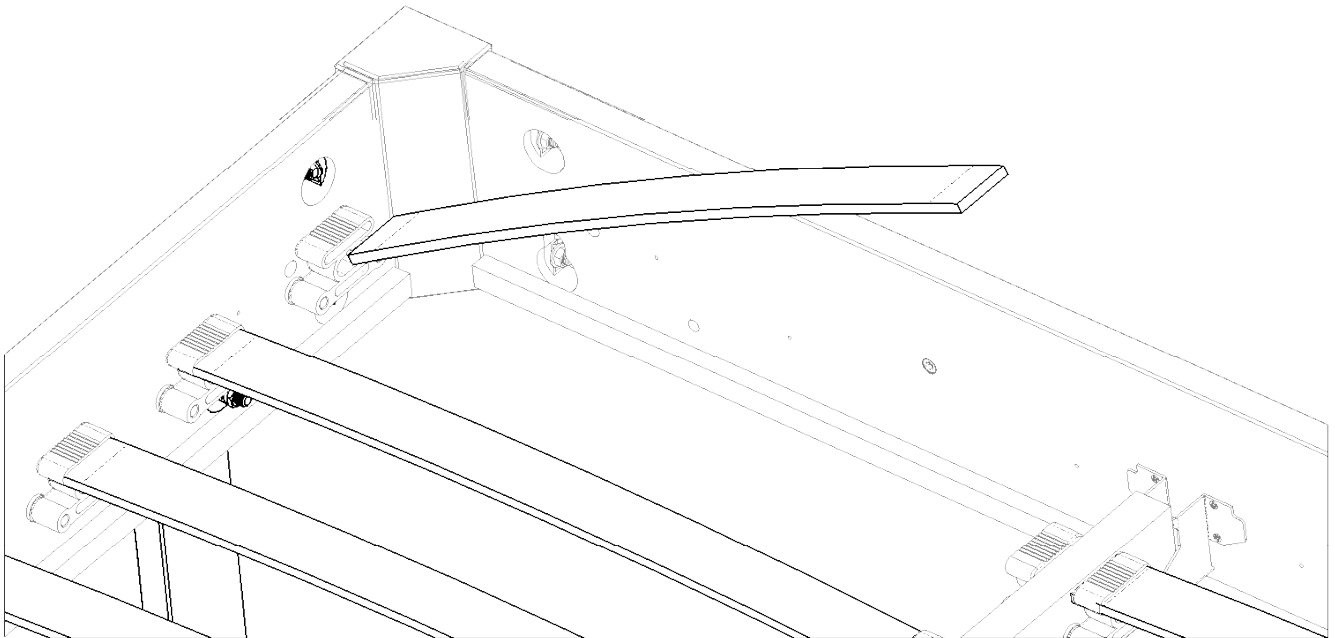
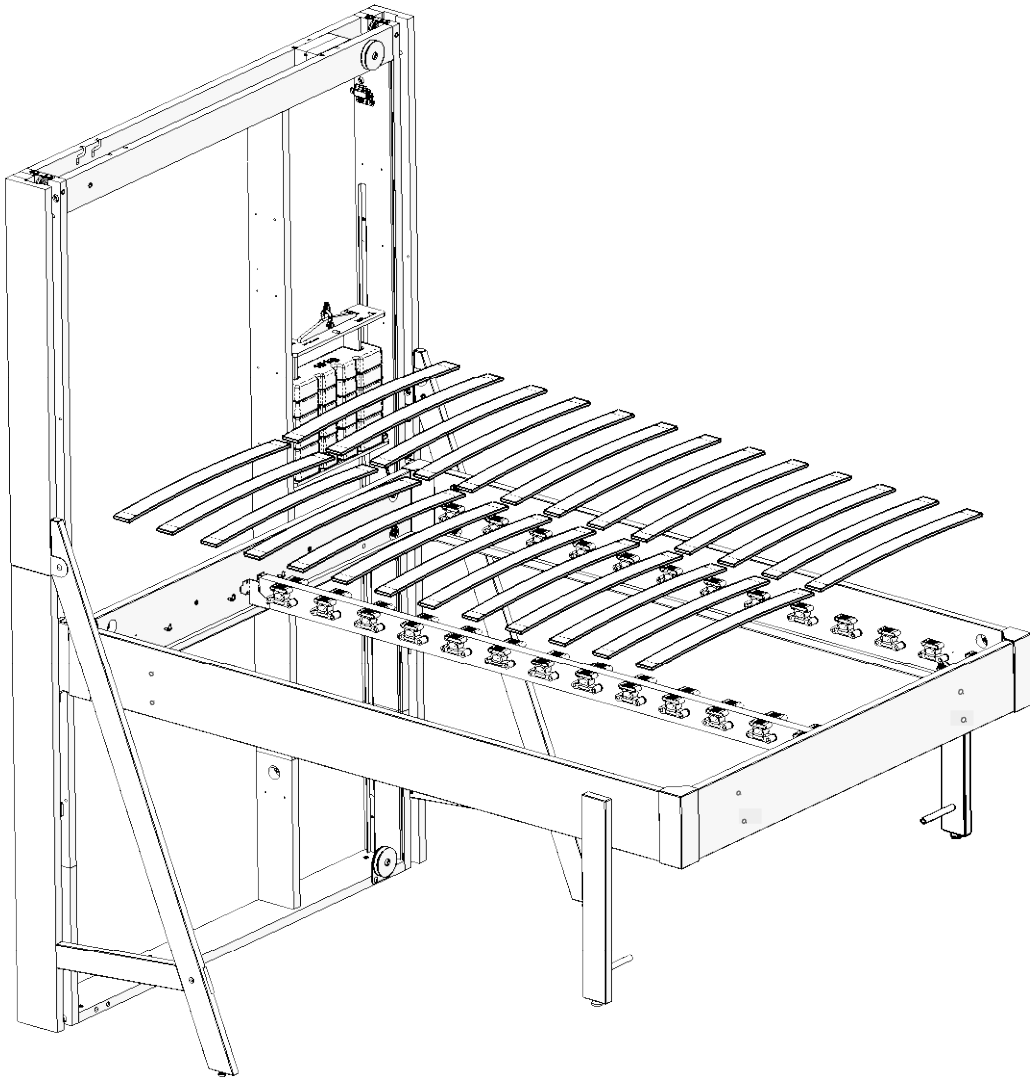

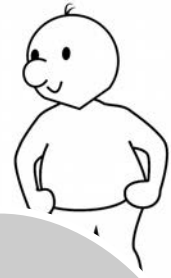

BALANCING & ADJUSTMENT

Add your mattress and your usual bedding (sheets, blanket or duvet, pillow, cuddly toys, etc.).

Unfold the legs if you haven't already.

Put your bed in the lowered position, locking it in place by inserting the pins in the frame (lowered position).

Place your mattress and bedding on top.

Put on work gloves and add weights (10 kg and 2 kg). Always remember to protect your back (carrying loads: knees bent, back straight).

Raise and lower the bed to check the balance.

Adjust the jacks on the bed legs and sliders.

To ensure that your bed is well balanced, stand on the frame side and apply slight pressure to the bed frame. The frame should not rise and all the jacks should be touching the floor.

The legs of the bed should be at right angles. Always secure them with the pins.

These steps are illustrated on the following pages.



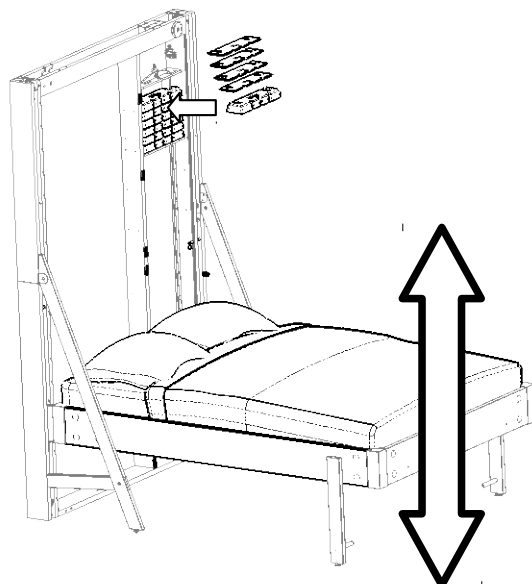
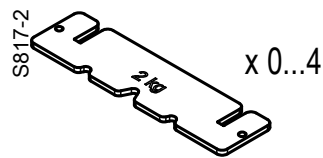
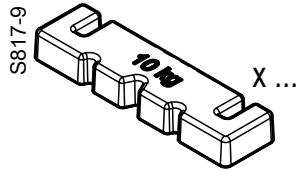
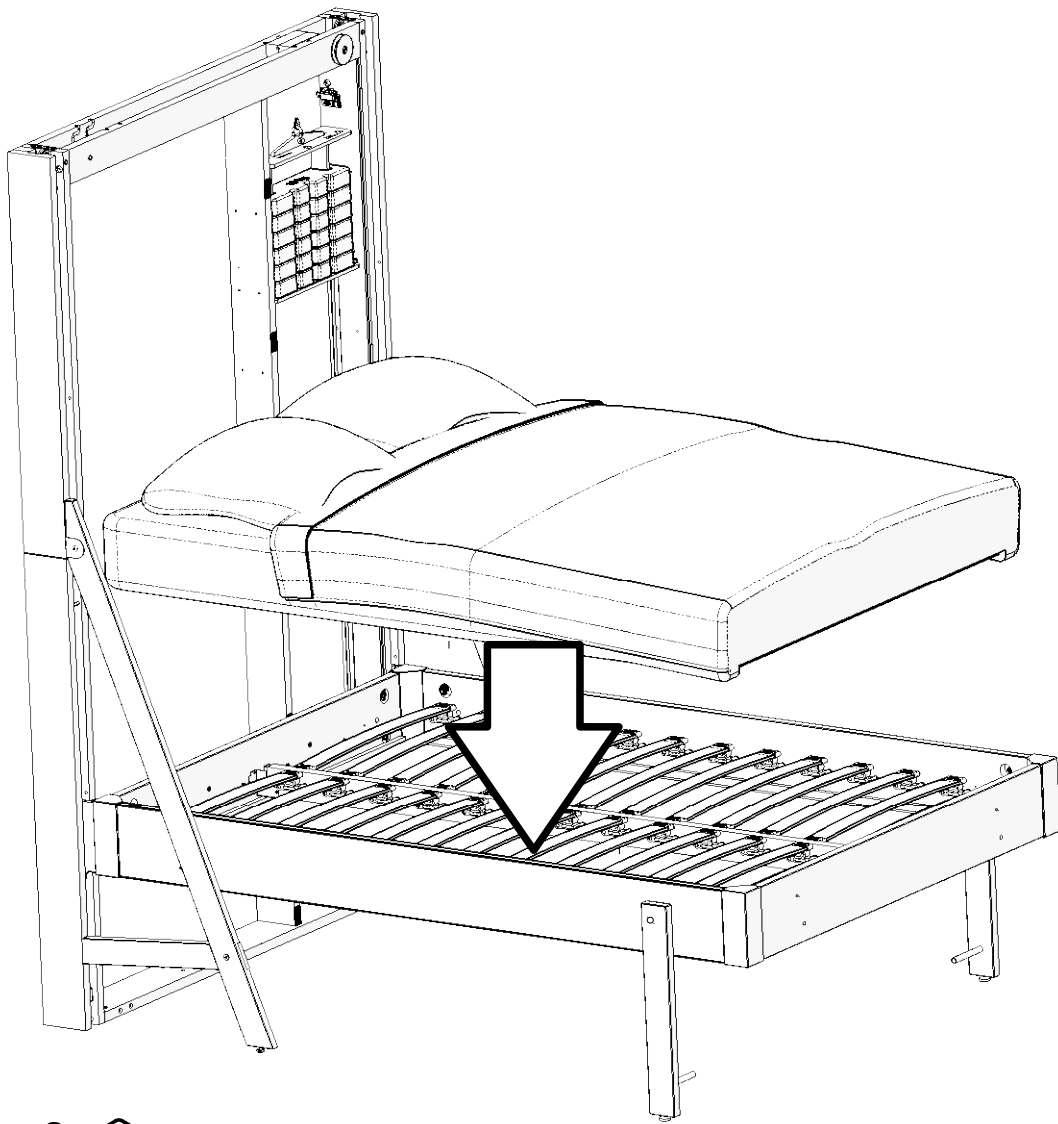

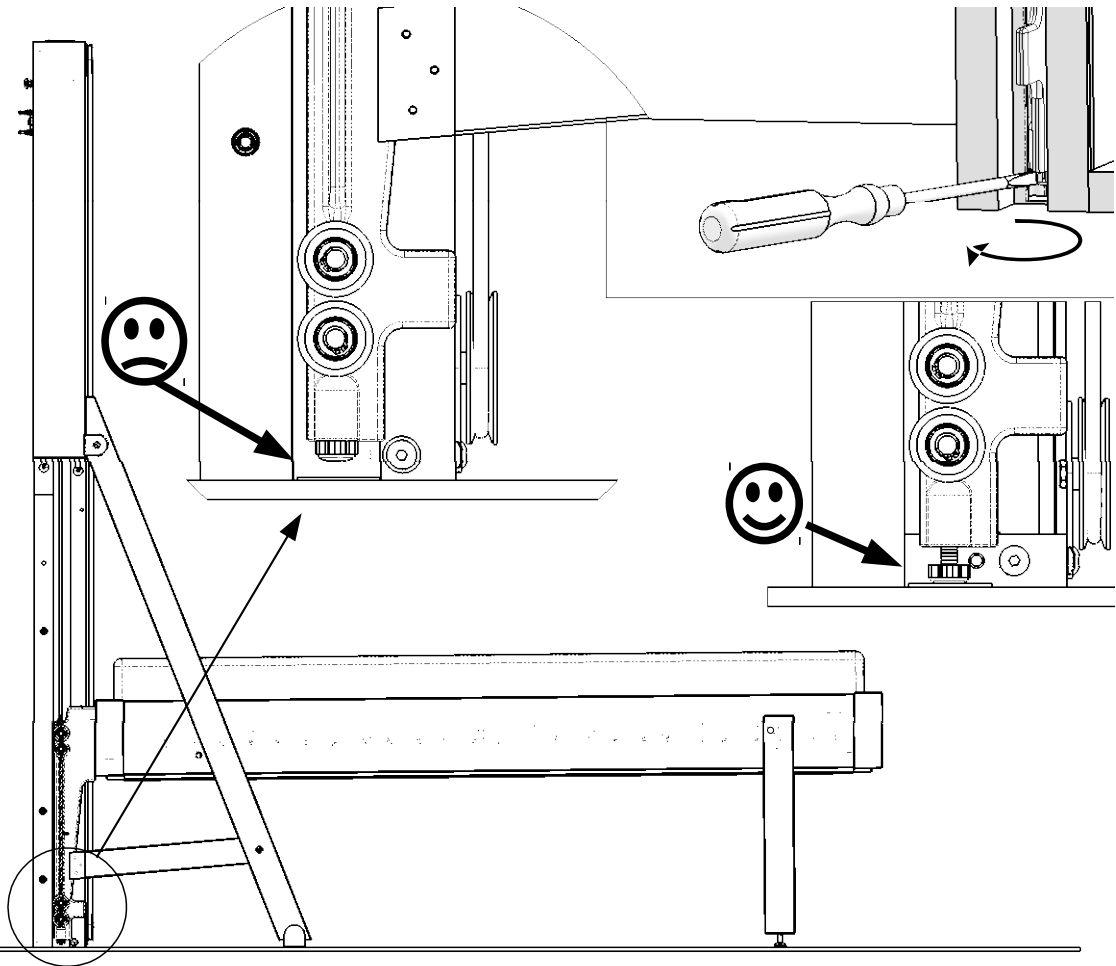
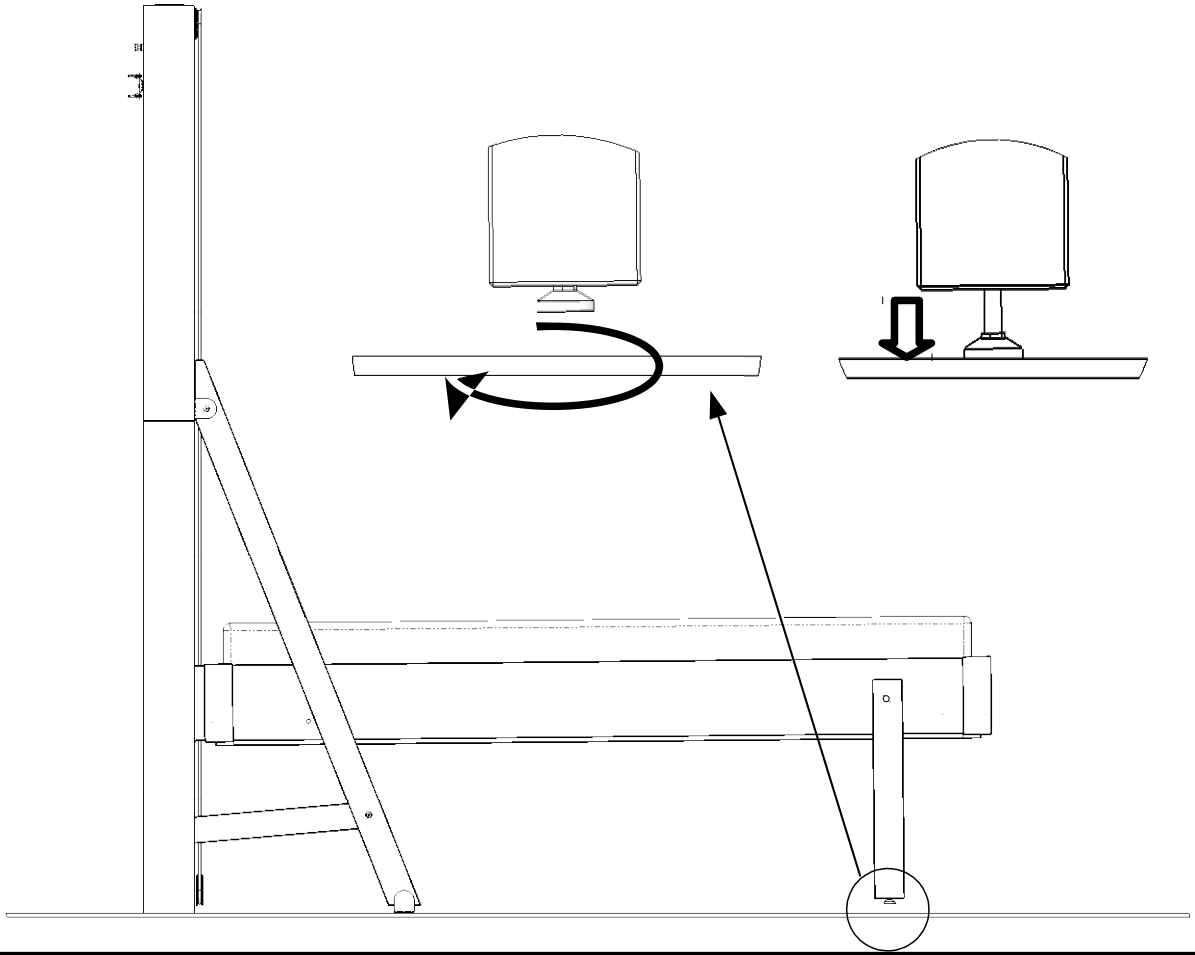

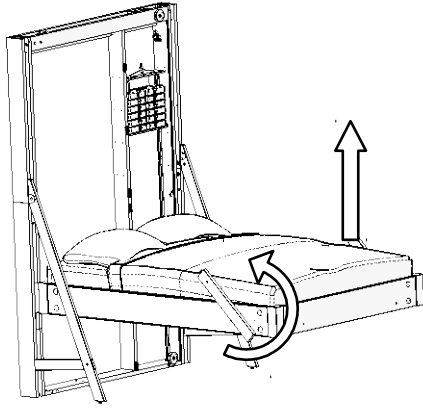

 n°7 N554-1 x 12

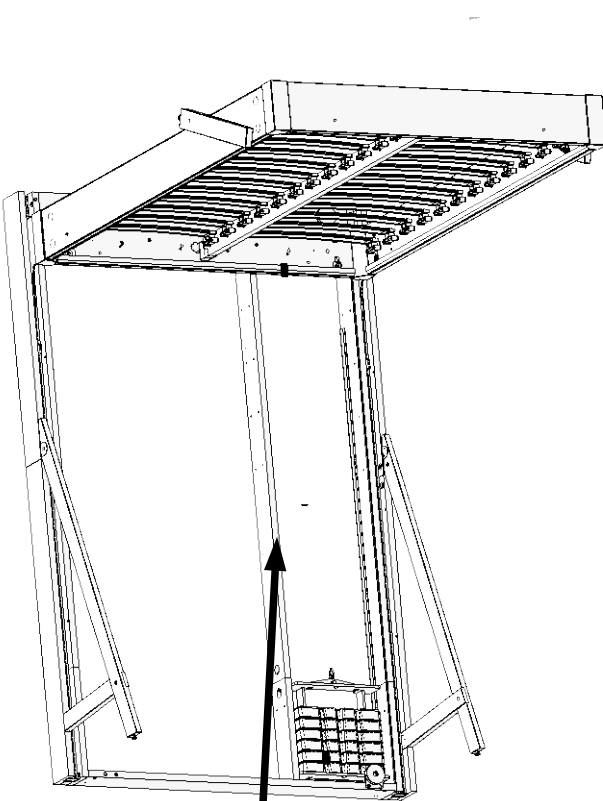
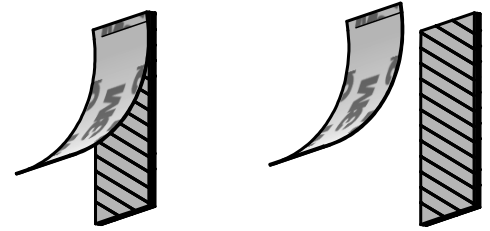
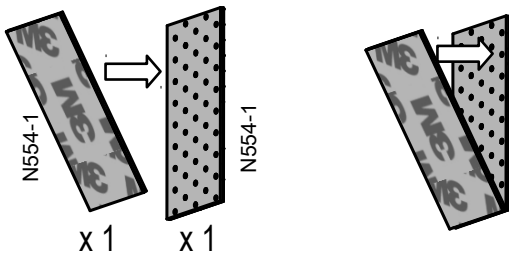

208cm

166cm

124cm

114cm

61cm

0cm

x6

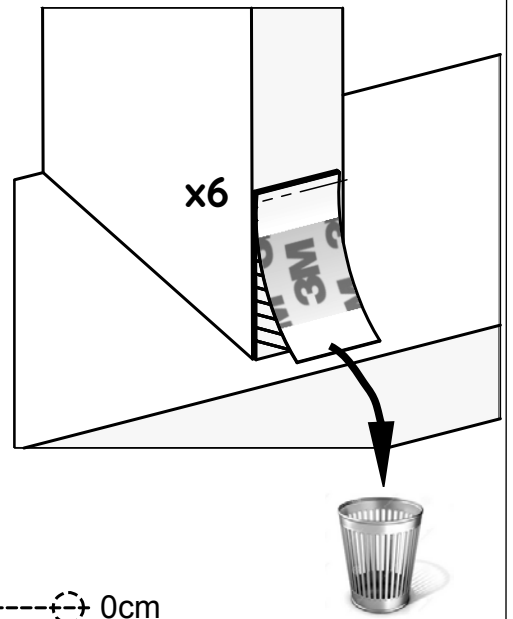
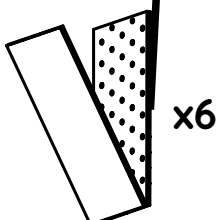

 n°10

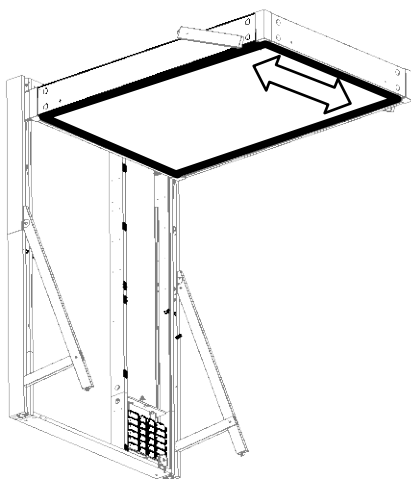
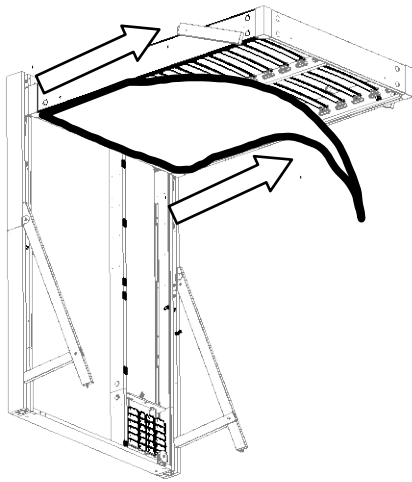
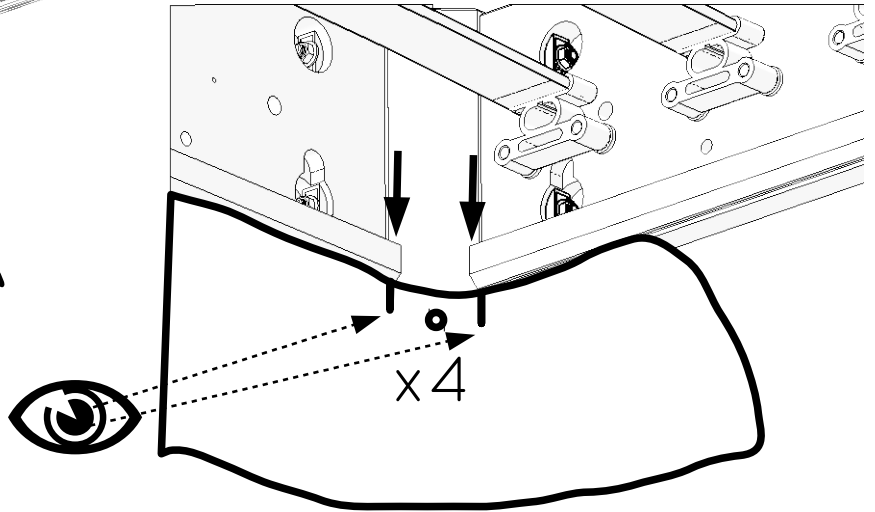
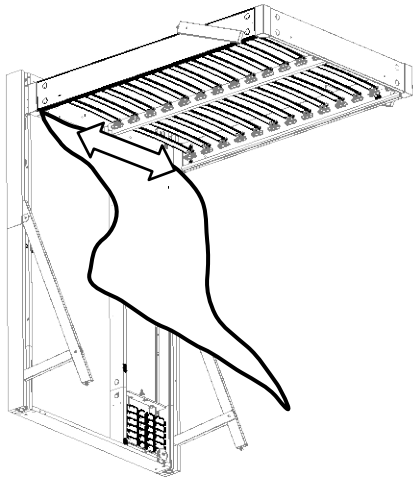
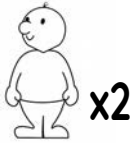

BEDBACK

Wash your hands
Start at the corners using the markings
Insert the edge of the bed base into the cleats



n°6



x 2

en°26



Clean the counterweight covers with a cloth.

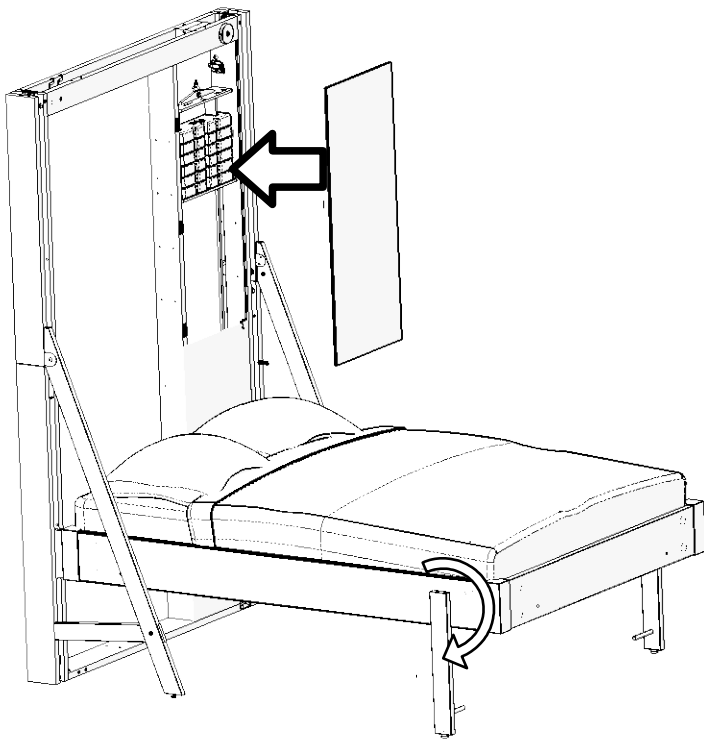
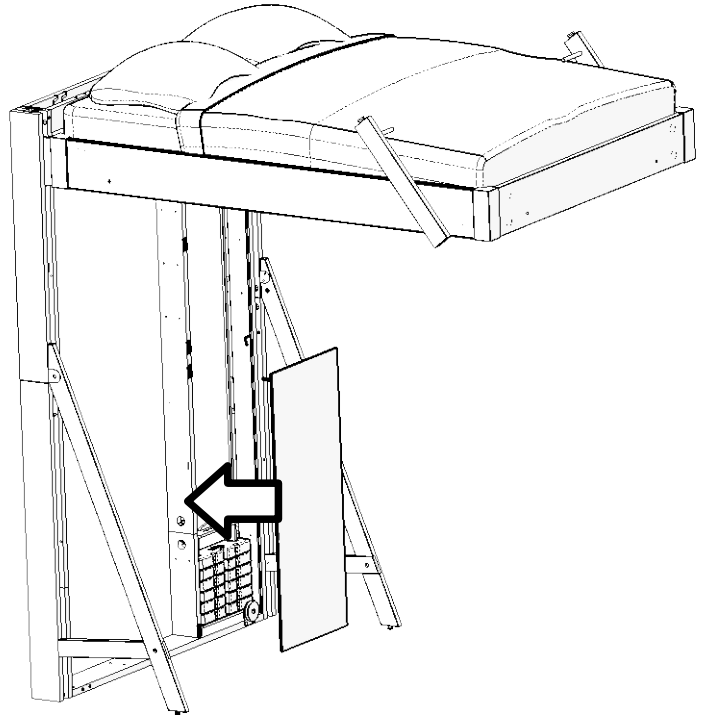
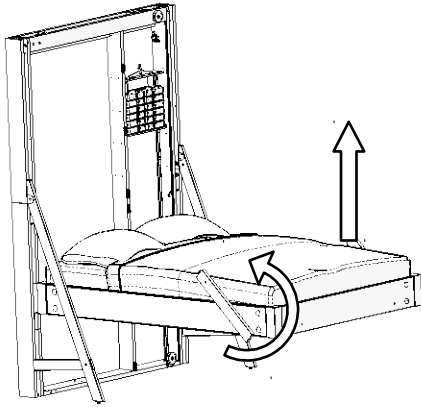

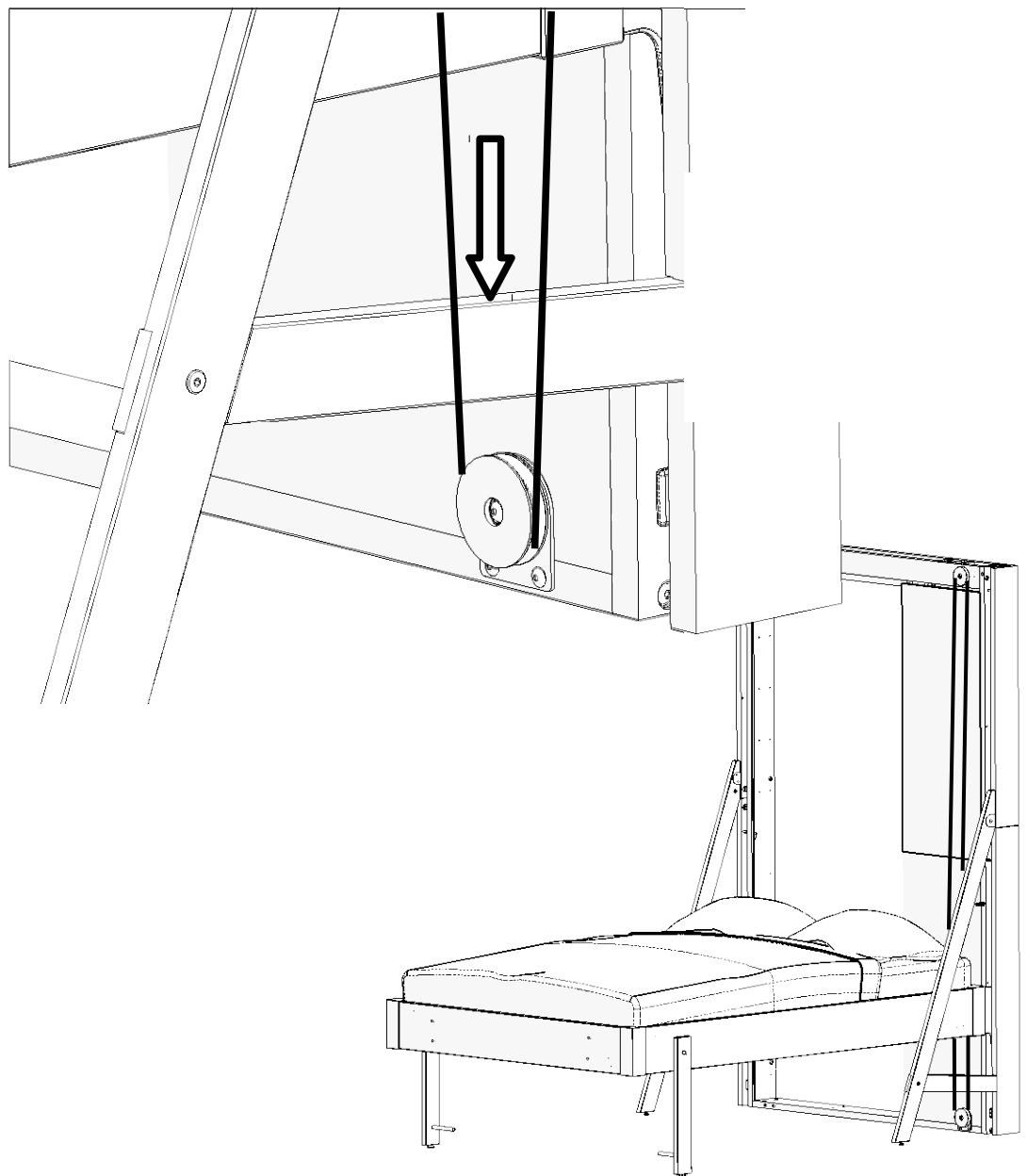
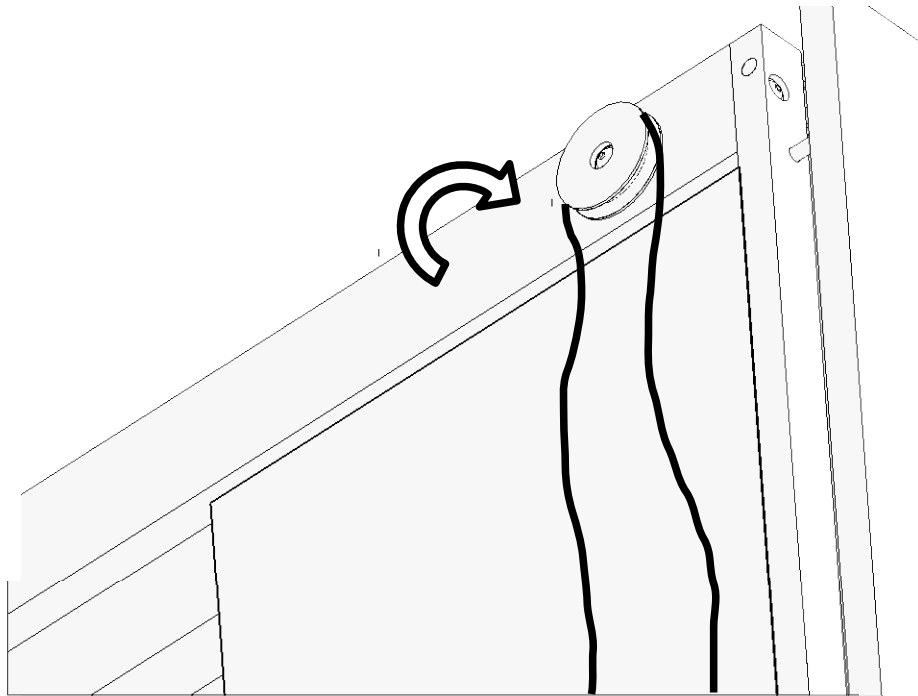

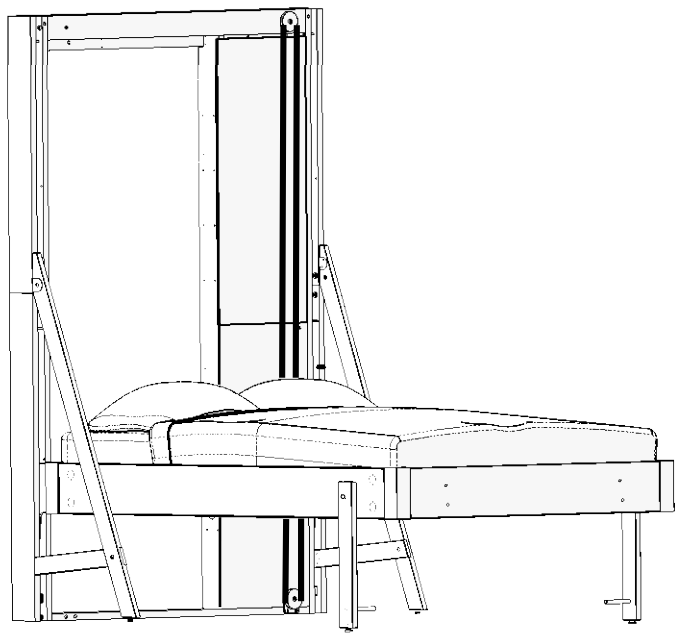
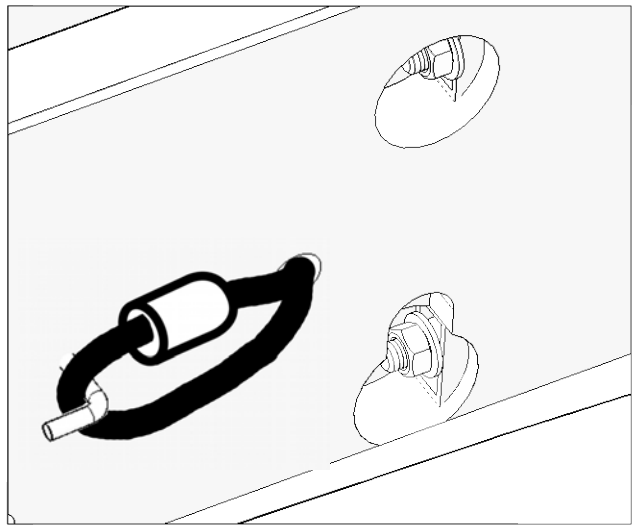
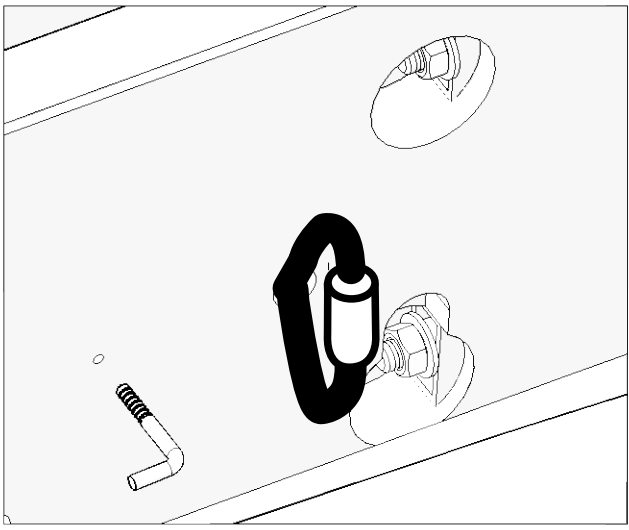
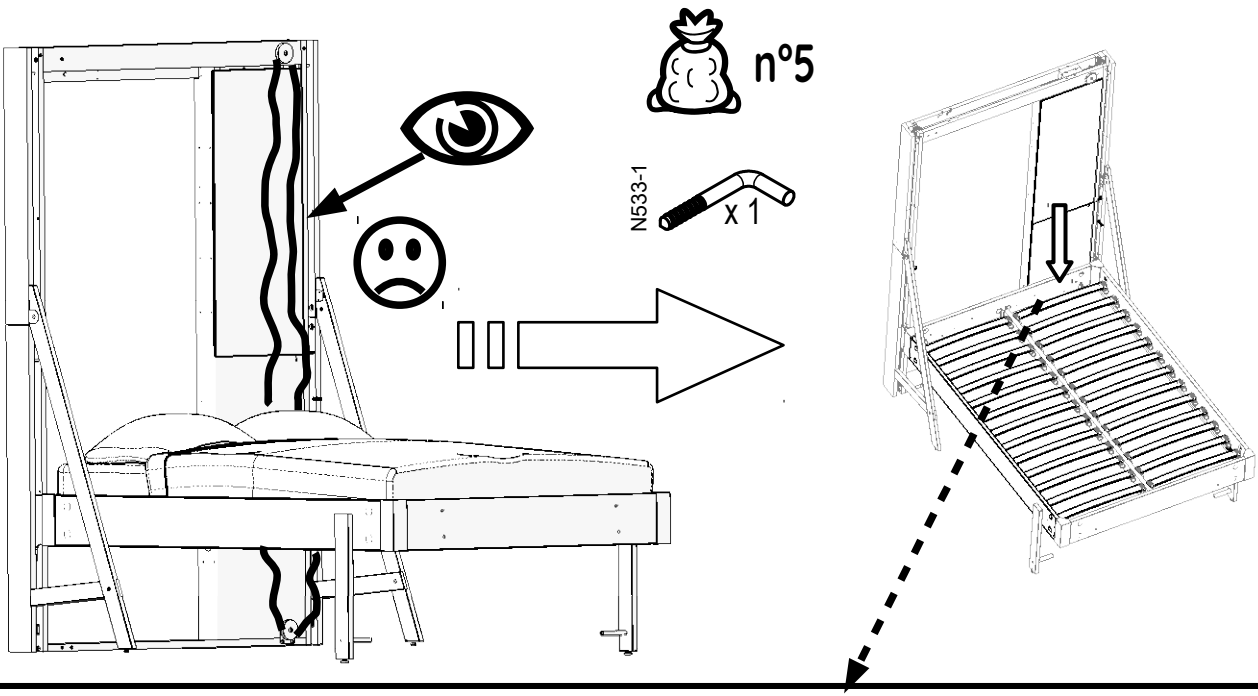

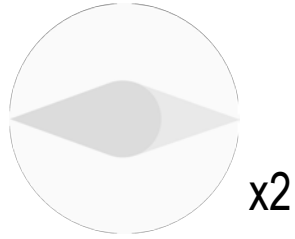
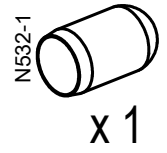
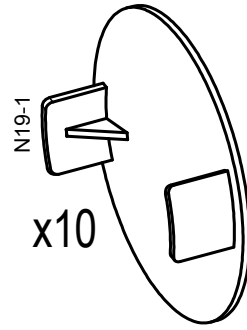
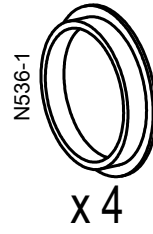
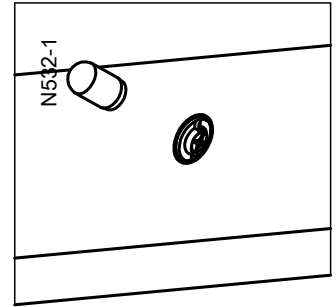
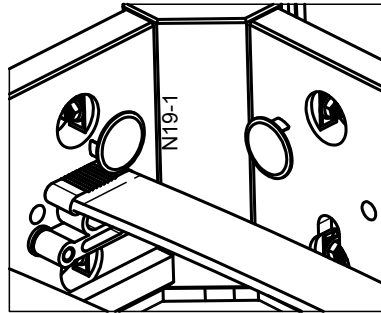
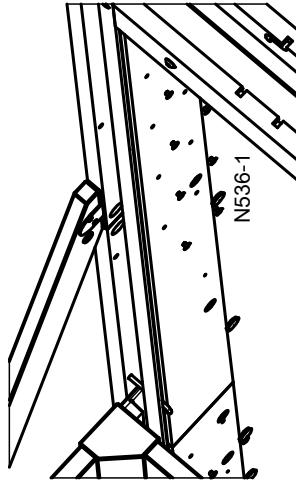
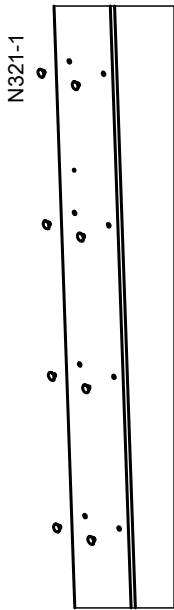



n°6



N546-4

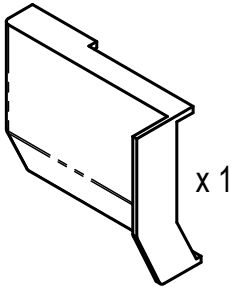

x 1



N546-5

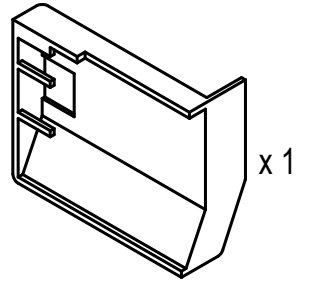

x 1

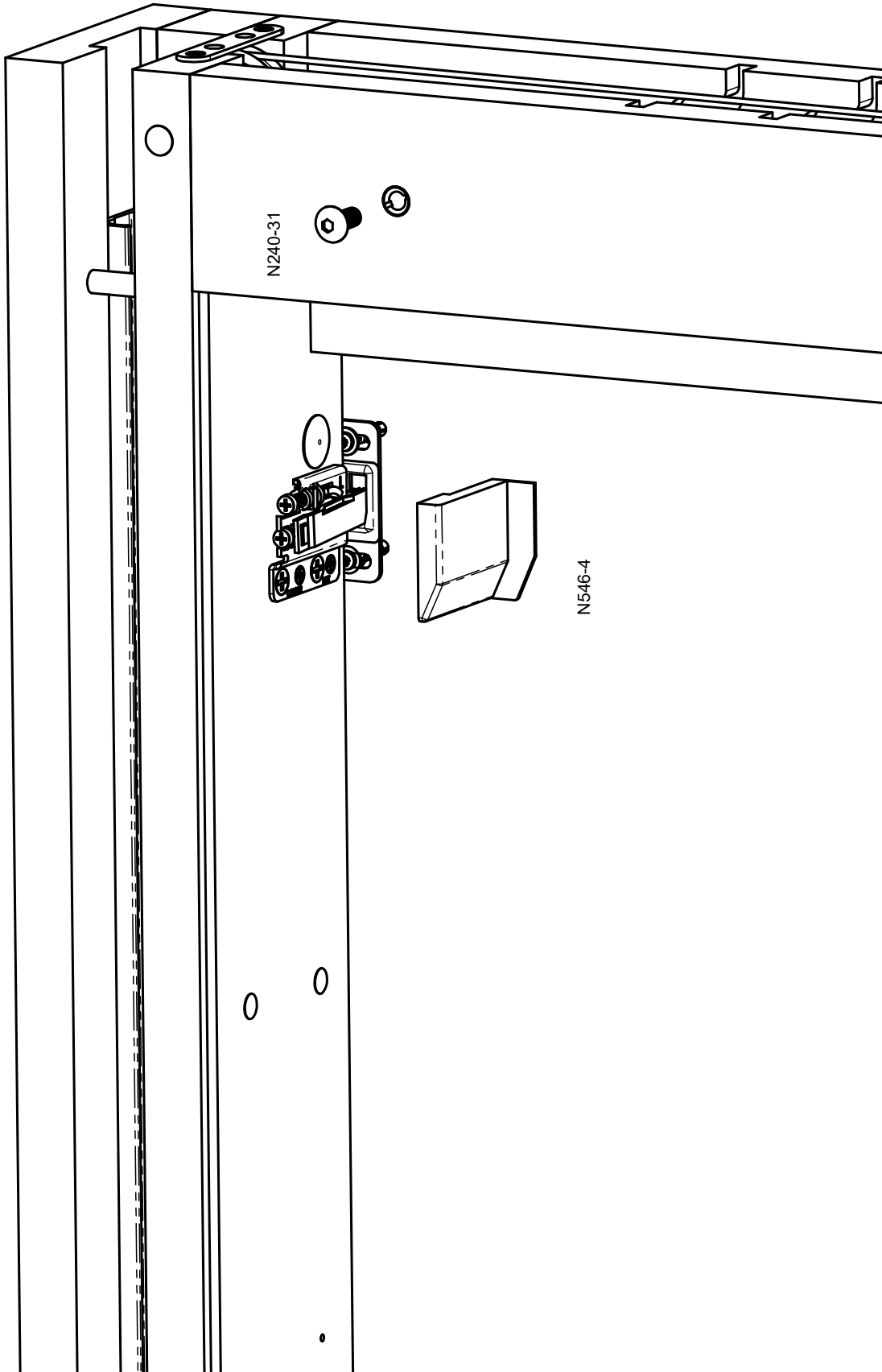

N240-31

N546-4



S864-1

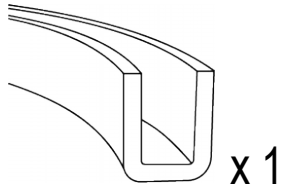

Cut rubber part N562-1 into thirds where the pins pass through, then insert them into the groove in the upright.

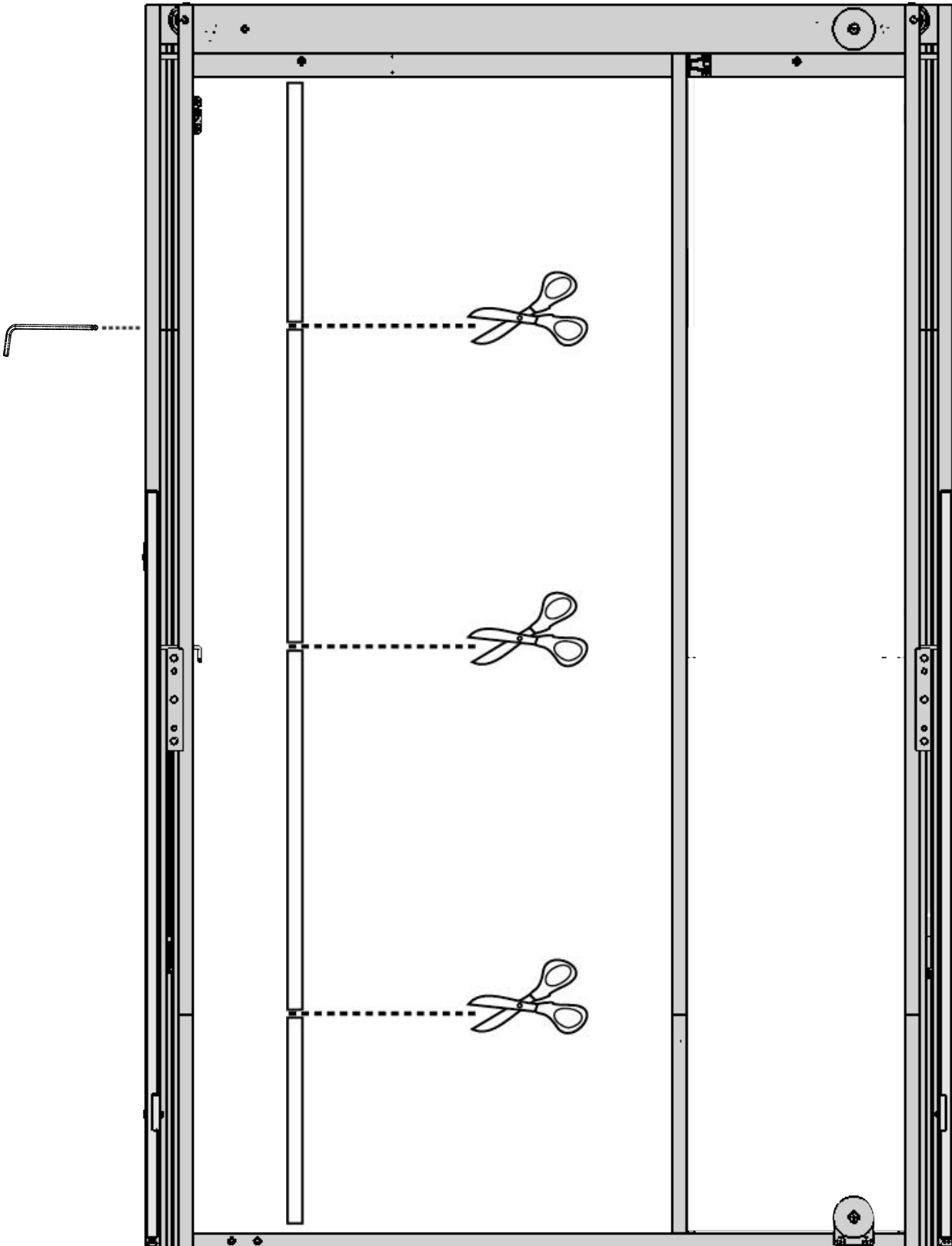

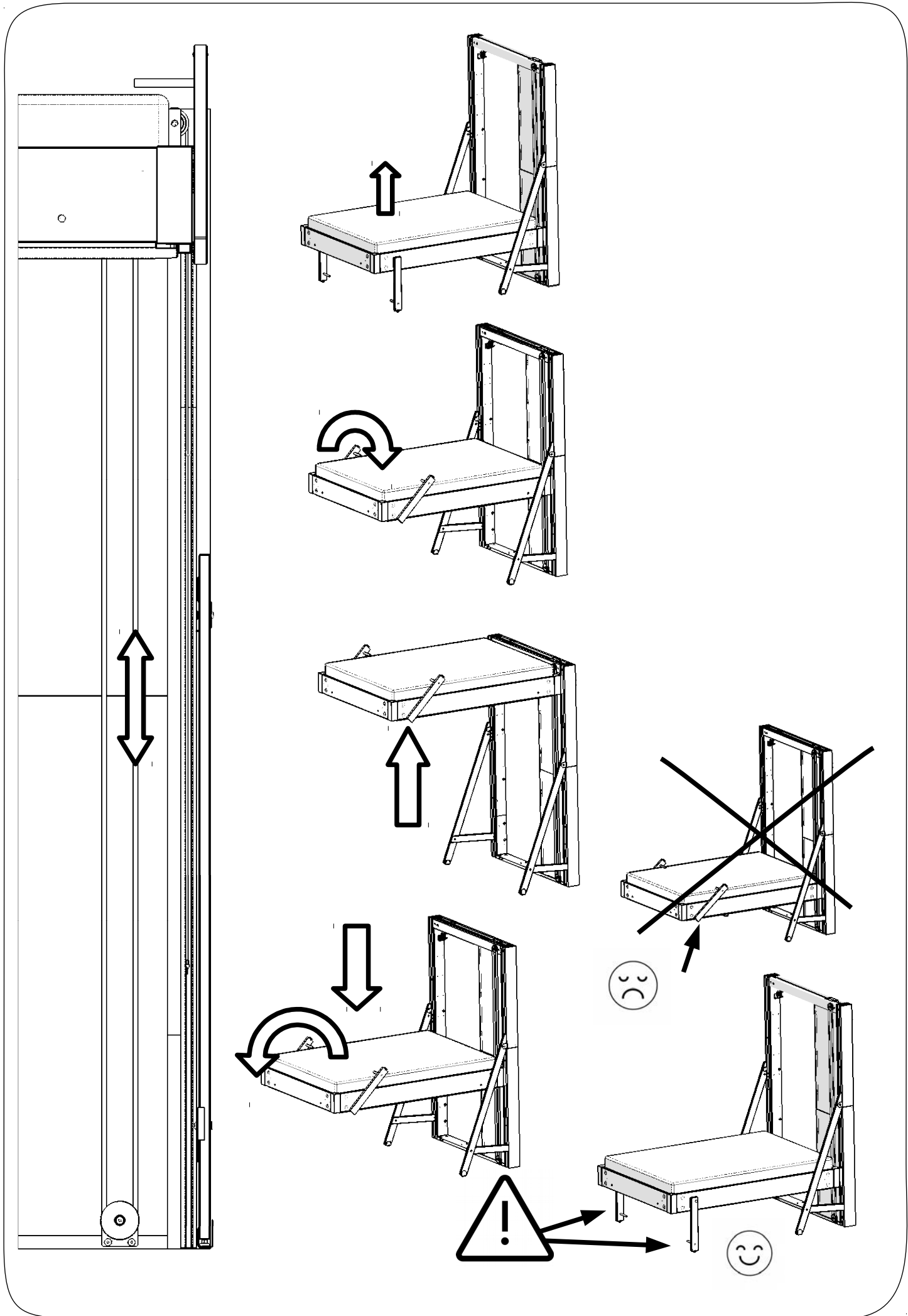



Instructions for use

Always lower the bed legs

The legs are at right angles to each other, always secure them with the pins

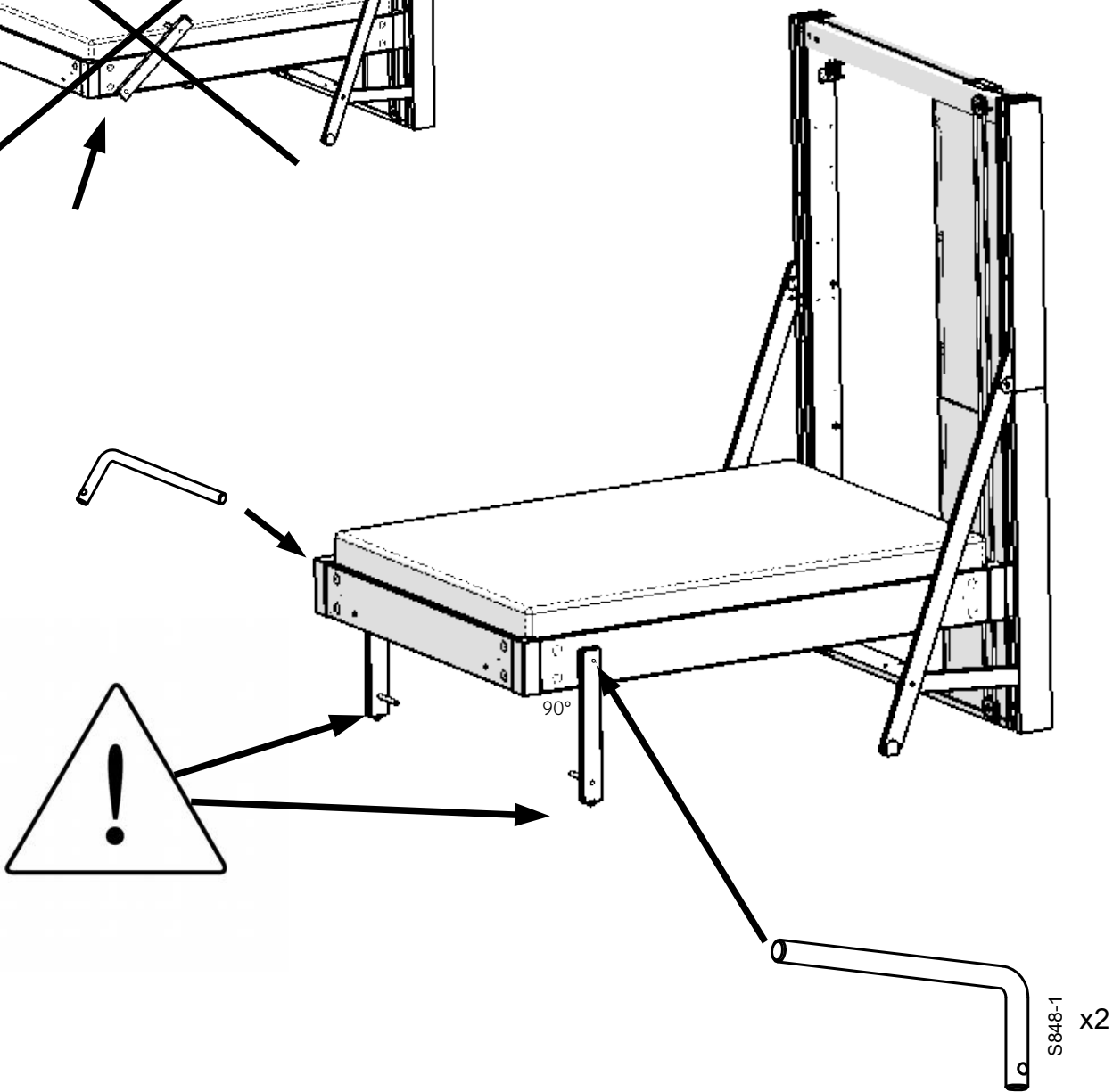
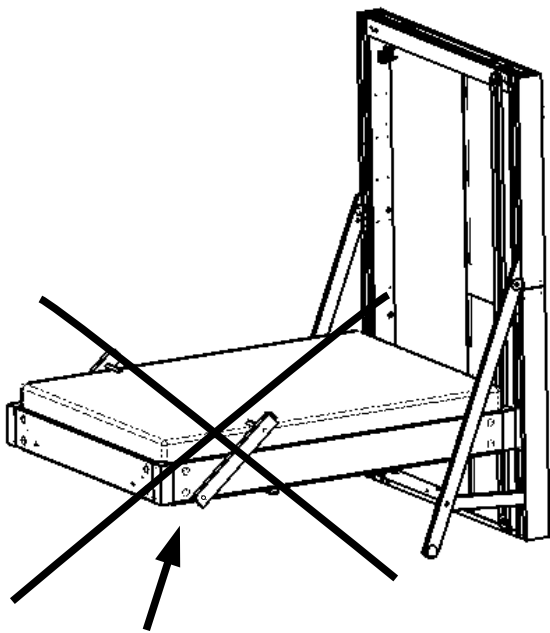



n°9

S817-2

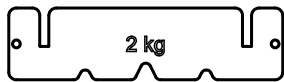

x 2

N240-21

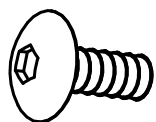

x 4

